

# JVC

## SERVICE MANUAL

### AUDIO/VIDEO CONTROL RECEIVER

## RX-772VBK

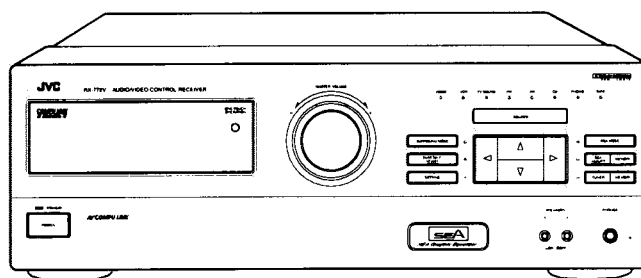
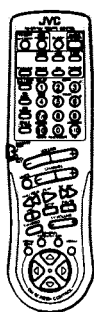

#### Area Suffix

C ..... Canada  
J ..... the U.S.A.

**COMPU LINK**  
/// Remote ///

**AV COMPU LINK**

### Contents

<i>Safety Precautions</i> .....	1-2	<i>Adjustment Procedures</i> .....	2-21
<i>Instruction Book</i> .....	1-3	<i>Block Diagrams</i> .....	2-22
<i>Description of Major ICs</i> .....	2-1	<i>Printed Circuit Boards</i> .....	2-25
<i>Internal Connection of Display</i> .....	2-14	<i>Schematic Diagrams</i> .....	2-29
<i>Disassembly Procedures</i> .....	2-16	<i>Parts List</i> .....	3-1

## Safety Precautions

1. The design of this product contains special hardware and many circuits and components specially for safety purposes. For continued protection, no changes should be made to the original design unless authorized in writing by the manufacturer. Replacement parts must be identical to those used in the original circuits. Services should be performed by qualified personnel only.
2. Alterations of the design or circuitry of the product should not be made. Any design alterations of the product should not be made. Any design alterations or additions will void the manufacturer's warranty and will further relieve the manufacture of responsibility for personal injury or property damage resulting therefrom.
3. Many electrical and mechanical parts in the products have special safety-related characteristics. These characteristics are often not evident from visual inspection nor can the protection afforded by them necessarily be obtained by using replacement components rated for higher voltage, wattage, etc. Replacement parts which have these special safety characteristics are identified in the Parts List of Service Manual. Electrical components having such features are identified by shading on the schematics and by ( $\Delta$ ) on the Parts List in the Service Manual. The use of a substitute replacement which does not have the same safety characteristics as the recommended replacement parts shown in the Parts List of Service Manual may create shock, fire, or other hazards.
4. The leads in the products are routed and dressed with ties, clamps, tubings, barriers and the like to be separated from live parts, high temperature parts, moving parts and/or sharp edges for the prevention of electric shock and fire hazard. When service is required, the original lead routing and dress should be observed, and it should be confirmed that they have been returned to normal, after re-assembling.

### 5. Leakage current check (Electrical shock hazard testing)

After re-assembling the product, always perform an isolation check on the exposed metal parts of the product (antenna terminals, knobs, metal cabinet, screw heads, headphone jack, control shafts, etc.) to be sure the product is safe to operate without danger of electrical shock.

Do not use a line isolation transformer during this check.

- Plug the AC line cord directly into the AC outlet. Using a "Leakage Current Tester", measure the leakage current from each exposed metal parts of the cabinet, particularly any exposed metal part having a return path to the chassis, to a known good earth ground. Any leakage current must not exceed 0.5mA AC (r.m.s.).
- Alternate check method  
Plug the AC line cord directly into the AC outlet. Use an AC voltmeter having, 1,000 ohms per volt or more sensitivity in the following manner. Connect a 1,500 $\Omega$  10 W resistor paralleled by a 0.15  $\mu$ F AC-type capacitor between an exposed metal part and a known good earth ground.

Measure the AC voltage across the resistor with the AC voltmeter.

Move the resistor connection to each exposed metal part, particularly any exposed metal part having a return path to the chassis, and measure the AC voltage across the resistor.

Now, reverse the plug in the AC outlet and repeat each measurement. Any voltage measured must not exceed 0.75 V AC (r.m.s.). This corresponds to 0.5 mA AC (r.m.s.).

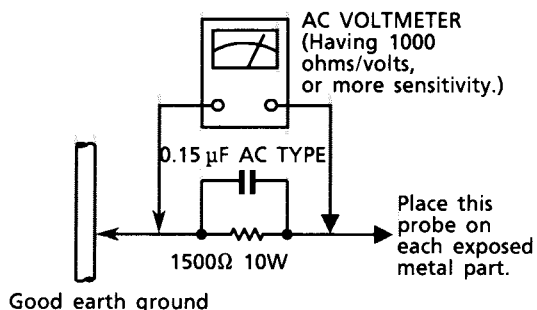

## Warning

1. This equipment has been designed and manufactured to meet international safety standards.
2. It is the legal responsibility of the repairer to ensure that these safety standards are maintained.
3. Repairs must be made in accordance with the relevant safety standards.
4. It is essential that safety critical components are replaced by approved parts.
5. If mains voltage selector is provided, check setting for local voltage.

# Instruction Book

## Getting Started

This section explains how to connect audio/video components and speakers to the receiver, and how to connect the power supply.

## Before Installation

### General

- Be sure your hands are dry.
- Turn the power off to all components.
- Read the manuals supplied with the components you are going to connect.

### Locations

- Install the receiver in a location that is level and protected from moisture.
- The temperature around the receiver must be between 23° and 95° F (-5° and 35° C).
- Make sure there is good ventilation around the receiver. Poor ventilation could cause overheating and damage the receiver.

### Handling the receiver

- Do not insert any metal object into the receiver.
- Do not disassemble the receiver or remove screws, covers, or cabinet.
- Do not expose the receiver to rain or moisture.

## Checking the Supplied Accessories

Check to be sure you have all of the following items, which are supplied with the receiver. The number in the parenthesis indicates the quantity of the pieces supplied.

- Remote Control (1)
- Batteries (2)
- AM Loop Antenna (1)
- FM Antenna (1)

If anything is missing, contact your dealer immediately.

## Table of Contents

Getting Started .....	2
Before Installation .....	2
Checking the Supplied Accessories .....	2
Switches, Buttons and Controls .....	3
Connecting the FM and AM Antennas .....	5
Connecting the Speakers .....	6
Connecting Audio/Video Components .....	8
Connecting the Power Cord .....	10
Putting Batteries in the Remote Control .....	10
<b>Basic Operations</b> .....	<b>11</b>
Turning the Power On and Off .....	11
Selecting the Source to Play .....	11
Adjusting the Volume .....	12
Selecting the Front Speakers .....	12
Muting the Sound .....	13
Recording a Source .....	13
<b>Basic Settings</b> .....	<b>14</b>
Adjusting the Front Speaker Output Balance .....	14
Listening at Low Volume (Loudness) .....	14
Using the Sleep Timer .....	15
Selecting the Center Speaker Size .....	16
Using Visual Confirmation .....	17
<b>One Touch Operation</b> .....	<b>18</b>
About the One Touch Operation .....	18
Using the One Touch Operation .....	18
<b>Receiving Radio Broadcasts</b> .....	<b>19</b>
Tuning in Stations Manually .....	19
Using Preset Tuning .....	19
Selecting the FM Reception Mode .....	20
Assigning Names to Preset Stations .....	21
Using the SEA Modes .....	22
Selecting Your Favorite SEA Mode .....	22
Creating Your Own SEA Mode .....	23
Using the Surround Processor .....	24
Using JVC's Hall Surround .....	24
Speaker arrangements for Dolby Surround .....	26
Preparing for Dolby Surround .....	27
Using Dolby Surround .....	30
Using the On-Screen Display to Control the Receiver .....	31
COMPU LINK Remote Control System .....	35
AV COMPU LINK Remote Control System .....	36
Using the Remote Control for Operating JVC's Audio/Video Components .....	38
Operating Other Manufacturers' VCR, TV, CATV Converter, and Satellite Tuners .....	40
Troubleshooting .....	46
Specifications .....	47

This mark indicates that you can also use the menu function to do the same operations. Actual operations using the menu function are explained on the pages indicated next to the marks.



**Switches, Buttons and Controls**

Become familiar with the main switches and controls on your receiver before use.

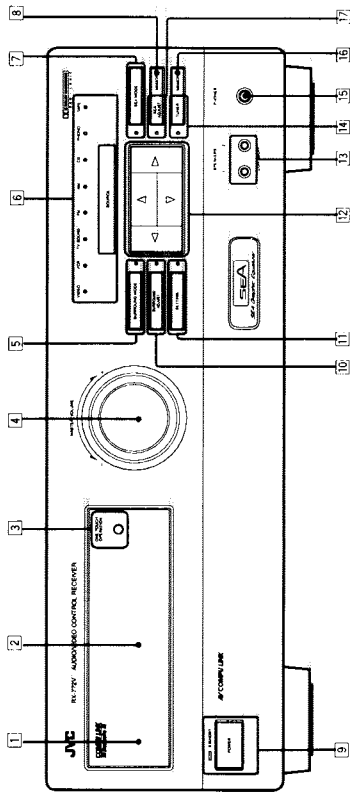

Refer to the pages in parentheses for details.

**Front Panel**

- 1 Remote sensor (10)
- 2 Display (11)
- 3 ONE TOUCH OPERATION button and lamp (18)
- 4 MASTER VOLUME control (12)
- 5 SURROUND MODE button and lamp (24, 27)
- 6 SOURCE button and lamps (11)
- 7 SEA MODE button and lamp (22)
- 8 MEMORY button for SEA adjustments (23)
- 9 POWER button and STANDBY lamp (11)
- 10 SURROUND ADJUST button and lamp (25, 27)
- 11 SETTING button and lamp (14 to 17)
- 12 Control  $\Delta / \nabla / \triangleleft / \triangleright$  buttons
- 13 SPEAKERS 1/2 buttons (12)
- 14 TUNER button and lamp (19)
- 15 PHONES jack (13)
- 16 MEMORY button for presetting channels (19)
- 17 SEA ADJUST button and lamp (23)

**IMPORTANT**  
**To use Control  $\Delta / \nabla / \triangleleft / \triangleright$  buttons (12) on the front panel:**  
 What these buttons actually do depends on which function you are trying to adjust. Before using these buttons, select the function by pressing one of the **function selecting buttons** (3, 5, 6, 7, 8, 9, 10, 11, 14, 17), and being sure its lamp is lit.  
 However, pressing MENU (3) on the remote control overrides the selected function and causes Control  $\Delta / \nabla / \triangleleft / \triangleright$  button to act like  $\Delta / \nabla / \triangleleft / \triangleright$  buttons (34) of the ON SCREEN CONTROL section of the remote control (though a lamp for the selected function remains lit).  
 To return the Control  $\Delta / \nabla / \triangleleft / \triangleright$  buttons to their usual behavior under the selected function, press the function button again.

**Remote Control**

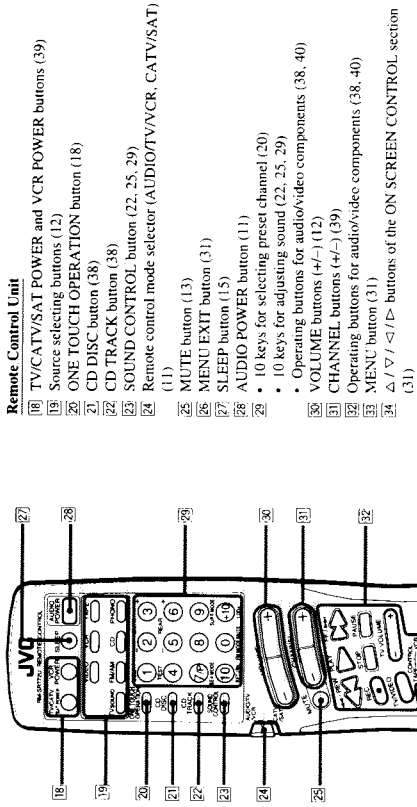

**Remote Control Unit**

- 18 TV/CATV/SAT POWER and VCR POWER buttons (39)
- 19 Source selecting buttons (12)
- 20 ONE TOUCH OPERATION button (18)
- 21 CD DISC button (38)
- 22 CD TRACK button (38)
- 23 SOUND CONTROL button (22, 25, 29)
- 24 Remote control mode selector (AUDIO/TV/VCR, CATV/SAT) (11)
- 25 MUTE button (13)
- 26 MENU EXIT button (31)
- 27 SLEEP button (15)
- 28 AUDIO POWER button (11)
- 29 10 keys for selecting preset channel (20)
- 30 10 keys for adjusting sound (22, 25, 29)
- 31 Operating buttons for audio/video components (38, 40)
- 32 VOLUME buttons (+/-) (12)
- 33 CHANNEL buttons (+/-) (39)
- 34 Operating buttons for audio/video components (38, 40)
- 35 MENU button (31)
- 36  $\Delta / \nabla / \triangleleft / \triangleright$  buttons of the ON SCREEN CONTROL section (31)

**IMPORTANT**

**When using the remote control:**  
 Check to see if its remote control mode selector (24) is set to the correct position.  
**To operate an audio system, TV, and VCR,** set it to the "AUDIO/TV/VCR" position.  
**To operate a CATV converter and satellite tuner,** set it to the "CATV/SAT" position.  
**About  $\Delta / \nabla / \triangleleft / \triangleright$  buttons (34) of the ON SCREEN CONTROL section on the remote control:**  
 If you press these buttons, the menu function starts operating. So, make sure you are showing the on-screen display on the TV before pressing these buttons.

**Connecting the FM and AM Antennas**

**FM Antenna Connections**

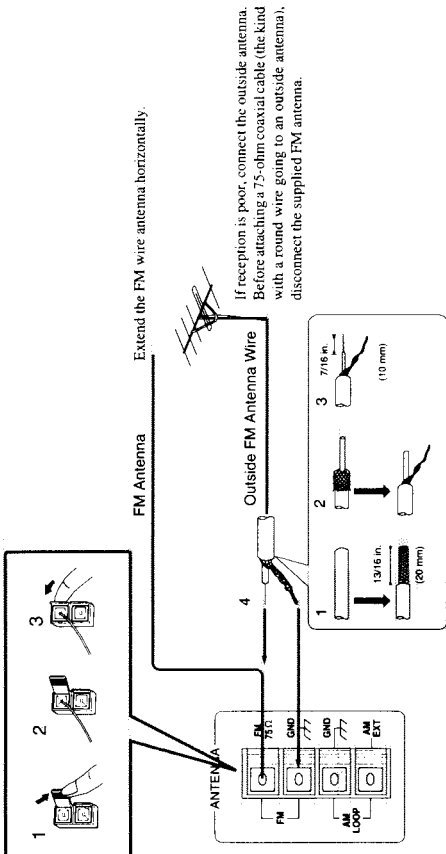

**How to strip the 75-ohm coaxial cable and connect it to the FM terminals**

1. Strip back the outside covering of the 75-ohm coaxial cable to expose the braided metallic mesh about 13/16 inches (20 mm).
2. Pull the mesh back and twist it into a single connector, as shown in the illustration above.
3. Strip the insulation about 7/16 inches (10 mm) back from the central wire.
4. Insert the twisted mesh and the central wire to the FM terminals, as shown in the illustration above.

**AM Antenna Connections**

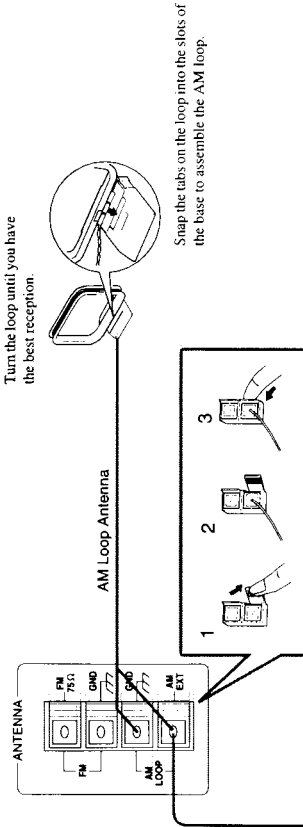

**Outdoor Single Vinyl-covered Wire**

If reception is poor, connect an outdoor single vinyl-covered wire to the AM EXT terminal. (Keep the AM loop antenna connected.)

**Note:**  
 • Make sure the antenna conductors do not touch any other terminals, connecting cords and power cord. This could cause poor reception.

**Connecting the Speakers**

You can connect the following speakers:

- Two pairs of front speakers to produce normal stereo sound.
- One pair of rear speakers to enjoy the surround effect.
- One center speaker to produce more effective surround effect (to emphasize human voices).
- One subwoofer to enhance the bass.

For each speaker (except for subwoofer), connect the black (-) and red (+) terminals on the rear panel to the black (-) and red (+) terminals marked on the speakers. For connecting a subwoofer, see page 7.

**CAUTION:**  
 Use speakers with the SPEAKER IMPEDANCE indicated by the speaker terminals.

**Connecting the front speakers**

Cut, twist and remove the insulation at the end of each speaker signal cable first, and then, connect the front speakers to the FRONT SPEAKERS terminals by using the cables. You can connect two pairs of front speakers (one pair to the FRONT SPEAKERS ① terminals, and another pair to the FRONT SPEAKERS ② terminals).

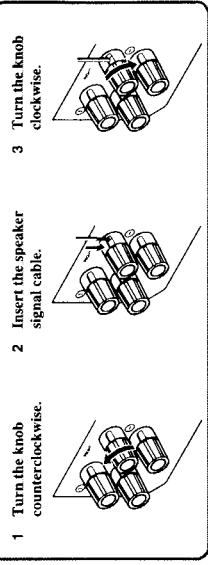
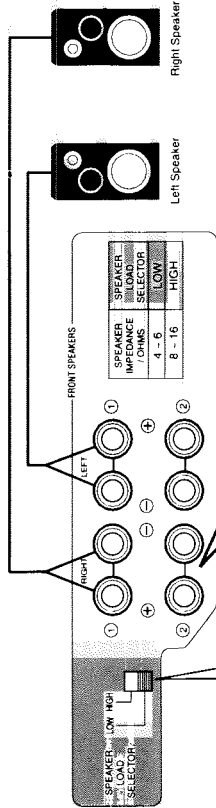

**Notes:**

- To obtain the best possible output power from the receiver, and to prevent the receiver from being overheated, the receiver has the SPEAKER LOAD SELECTOR which should be set to match the impedance of the connected speakers. Set this selector according to the indications by the FRONT SPEAKERS terminals.
- When you connect two pairs of the speakers to the FRONT SPEAKERS terminals, use the speakers having the impedance within the same range.

**Connecting the rear and center speakers**

Cut, twist and remove the insulation at the end of each speaker signal cable first, and then, connect rear speakers to the REAR SPEAKERS terminals and a center speaker to the CENTER SPEAKER terminals by using the cables.

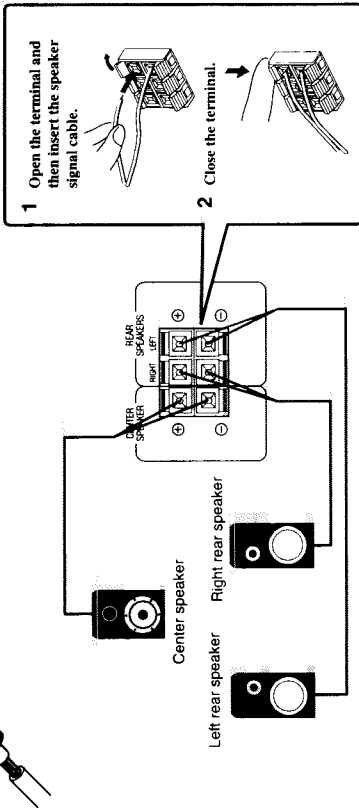

**Notes:**

- You can register the center speaker size after you finish its connection. If you register it, you do not have to set the center speaker mode when setting the surround mode. (If you do not use a center speaker, register that information.) See page 16.
- When you connect rear speakers, make sure that both left and right speakers are connected; otherwise, no sound will come out of the rear speakers.

**Connecting the subwoofer speaker**

You can enhance the bass by connecting a subwoofer. Connect the input jack of a powered subwoofer to the SUBWOOFER OUT jack on the rear panel, using a cable with RCA pin plugs.

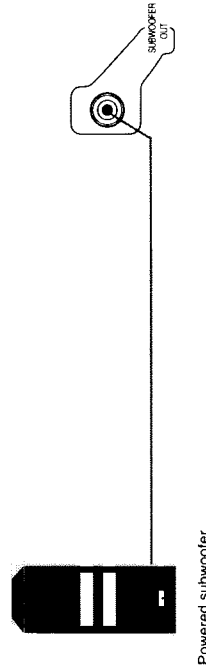

Powered subwoofer

**Connecting Audio/Video Components**

You can connect the following audio/video components to this receiver using cables with RCA pin plugs (not supplied). Refer also to the manuals supplied with your components. If you want to connect a component not listed in the table below, refer to the manual supplied with it.

Audio Components	Video Components
• Turntable	• TV
• CD player	• VCR
• Cassette deck	• Video disc player

**Note:**

- If you connect a sound-enhancing device such as a graphic equalizer between the source components and this receiver, the sound output through this receiver may be distorted.
- Any turntables incorporating a small-output cartridge such as an MC (moving-coil type) must be connected to this receiver through a commercial head amplifier or step-up transformer. Direct connection may result in insufficient volume.

**Audio component connections**

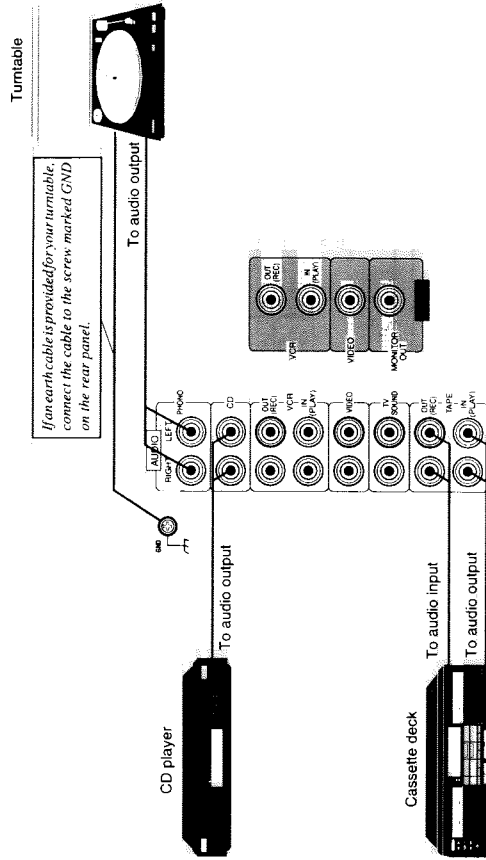

**If your audio components have a COMPU LINK-3 terminal**

The COMPU LINK remote control system allows you to control other JVC audio components from the receiver or vice versa. Connect your audio components and the receiver with the cable (monaural mini-plug supplied with those components) as well as the connection above. For detailed information about the connection and the COMPU LINK-3 remote control system, see page 35.

**Note:**

The COMPU LINK-3 remote control system is the upgraded version of the COMPU LINK-1 and COMPU LINK-2. Even if your component has the COMPU LINK-1 or COMPU LINK-2 jacks, you can still connect it in the COMPU LINK-3 remote control system, but some functions may not work correctly.

**Video component connections**

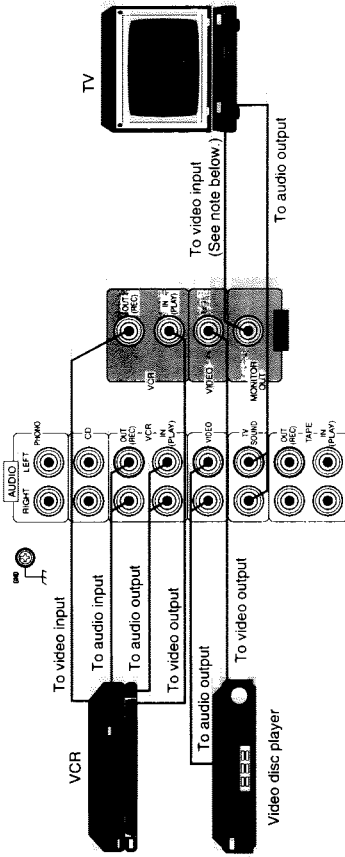

**Note:**

- When connecting a JVC TV:
- If you use the AV COMPU LINK remote control system to operate the TV, connect the receiver to the Video Input 2 jack on the TV.
- If you do not use the AV COMPU LINK remote control system to operate TV, connect the receiver to the Video Input 1 jack on the TV.

**If your video components have an AV COMPU LINK terminal**

The AV COMPU LINK remote control system allows you to control other JVC video components from the receiver or vice versa. For detailed information about the connection and the AV COMPU LINK remote control system, see page 36.

**Notes:**

- The AV COMPU LINK remote control system cannot control the video components connected to the VIDEO jacks on the receiver, but can control only the VCR connected to the VCR jacks.
- Some VCRs use the AV COMPU LINK jacks for the SWAP editing. However, you cannot use both the AV COMPU LINK remote control and the SWAP editing at the same time. For the SWAP editing, see the manual supplied with the VCR.

**Connecting the Power Cord**

Before plugging the receiver into an AC outlet, make sure that all connections have been made. When the power cord is connected, the STANDBY lamp above the POWER button lights up.

Keep the power cord away from the connecting cables for the TV, VCR, and antenna. The power cord may cause noise or screen interference. We recommend that you use a coaxial cable to connect the antenna, since it is well-shielded against interference.

**Notes:**

- A small amount of power is always consumed even in standby mode. To switch off the power completely, unplug the power cord from the AC outlet.
- If the power cord is unplugged or a power failure occurs, preset settings will be erased in a few days.

**CAUTIONS:**

- Do not touch the power cord with wet hands.
- Do not pull on the power cord to unplug the cord. When unplugging the cord, always grasp the plug so as not to damage the cord.

**Putting Batteries in the Remote Control**

Before using the remote control, put two supplied batteries first. When using the remote control, aim the remote control directly at the remote sensor on the receiver.

1. On the back of the remote control, remove the cover as illustrated.
2. Insert batteries. Make sure to observe the proper polarity: (+) to (+) and (-) to (-).
3. Replace the cover in.

R03 (UM-4)/AAA (24F)

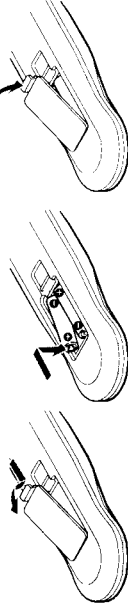

If the range or effectiveness of the remote control decreases, replace the batteries. Use two R03 (UM-4)/AAA (24F) type dry-cell batteries.

**CAUTIONS:**

- Follow these precautions to avoid leaking or cracking cells:
- Place batteries in the remote control so they match the polarity indicated: (+) to (+) and (-) to (-).
- Use the correct type of batteries. Batteries that look similar may differ in voltage.
- Always replace both batteries at the same time.
- Do not expose batteries to heat or flame.

### Basic Operations

The following operations are commonly used when you play any sound source.

#### IMPORTANT

When using the Remote Control, check to see if its remote control mode selector is set to the correct position:  
**To operate an audio system, TV, and VCR,** set it to the "AUDIO/TV/VCR" position.  
**To operate a CATV converter and satellite tuner,** set it to the "CATV/SAT" position.



### Turning the Power On and Off



Front panel



Remote Control

**On the front panel:**  
**To turn on the power,** press **POWER**.  
 The **STANDBY** lamp goes off. The name of the current source (or station frequency) appears on the display.

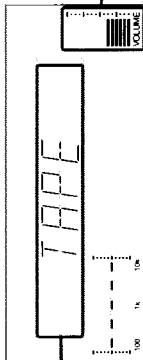

Current source name appears

**To turn off the power,** press **POWER** again.  
 The **STANDBY** lamp lights up.

**From the remote control:**  
**To turn on the power,** press **AUDIO POWER**.  
 The **STANDBY** lamp goes off. The name of the current source appears on the display.

**To turn off the power,** press **AUDIO POWER** again.  
 The **STANDBY** lamp lights up.



Remote Control



See also page 31.

### Selecting the Source to Play

You need to select the source before you start playing any source.

**On the front panel:**

1. Press **SOURCE** so that the **Control Δ / ▽** buttons work for selecting the source.
2. Press **Control Δ / ▽** until the source name you want appears on the display.

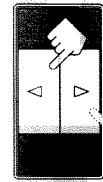
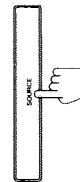

Front panel

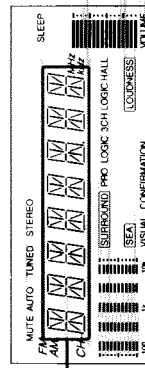

Selected source name appears

### From the remote control:

- Press one of the source selecting buttons you want.**
- VIDEO** Play back a video source on the video component connected to the **VIDEO** jacks.
  - VCR** Play back a video source on the video component connected to the **VCR** jacks.
  - TV SOUND** Listen to TV sounds.
  - FM/AM\*** Listen to the radio.
  - TAPE\*** Each time you press the button, the band alternates between **FM** and **AM**.
  - CD\*** Listen to a cassette tape connected to the **TAPE** jacks.
  - PHONO\*** Listen to a CD.
  - Listen to a record.

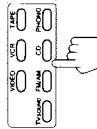

Remote Control

### Note:

When you press one of the source selecting buttons marked above with an asterisk (\*), the receiver automatically turns on.

### Adjusting the Volume

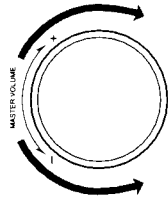

When you change the volume level, the volume level is shown on the display.

### On the front panel:

- To increase the volume,** turn **MASTER VOLUME** clockwise.
- To decrease the volume,** turn **MASTER VOLUME** counterclockwise.

### Note:

When you turn **MASTER VOLUME** rapidly, the volume level also changes rapidly. When you turn **MASTER VOLUME** slowly, the volume level also changes slowly.

### From the remote control:

- To increase the volume,** press **VOLUME +**.
- To decrease the volume,** press **VOLUME -**.



Remote Control

### CAUTION:

Always set the volume level to the minimum before starting any source. If the volume level is left turned up, the sudden blast of sound energy can permanently damage your hearing and/or ruin your speakers.

### Selecting the Front Speakers

### On the front panel only:

When you have connected two pairs of the front speakers, you can select which to use. Pressing **SPEAKERS 1** or **SPEAKERS 2** to set it in the **-ON** position activates the respective pair of the speakers.

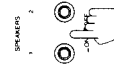

Front panel

**To use the speakers connected to the FRONT SPEAKERS 1 terminals,** press **SPEAKERS 1** to set it in the **-ON** position, and press **SPEAKERS 2** to set it in the **-OFF** position.  
**To use the speakers connected to the FRONT SPEAKERS 2 terminals,** press **SPEAKERS 2** to set it in the **-ON** position, and press **SPEAKERS 1** to set it in the **-OFF** position.  
**To use both pairs of the speakers,** press both **SPEAKERS 1** and **2** to set them in the **-ON** position.  
**To use neither pair of the speakers,** press both **SPEAKERS 1** and **2** to set them in the **-OFF** position.

### Note:

When only one set of the speakers is connected to either the **FRONT SPEAKERS 1** or **2** terminals, do not press both **SPEAKERS 1** and **2** to set them in the **-ON** position. If you do, no sound comes out of the front speakers.



**Listening with Headphones**

A standard pair of headphones can be connected to the PHONES jack on the front panel.

To listen with only headphones, press both SPEAKERS 1 and 2 to set them in the OFF position. No sound comes out of the front speakers.

**CAUTION:**

Be sure to turn down the volume before connecting or putting on headphones, as high volume can damage both the headphones and your hearing.

**Muting the Sound**



Remote Control

From the remote control only:

To mute the sound through all the speakers and headphones connected, press MUTE so that "MUTE" appears on the display and the volume turns off.

To cancel the mute, press MUTE again so that "OFF" appears on the display.

Turning MASTER VOLUME or pressing VOLUME +/- also restores the sound at the previous volume level.

**Recording a Source**

You can record any source playing through the receiver to the cassette deck connected to the TAPE jacks and the VCR connected to the VCR jacks at the same time. While recording, you can listen to the selected sound source at whatever sound level you like, without affecting the sound levels of the recording.

Note:

The output volume level, SEA and surround adjustments cannot affect the recording.

**Basic Settings**

Some of the following settings are required after connecting and positioning your speakers in your listening room, while others will make operations easier.



See also page 31.

**Adjusting the Front Speaker Output Balance**

If the sounds you hear from the front right and left speakers are unequal, you can adjust the speaker output balance.

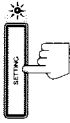

On the front panel only:

1. Press SETTING so that the Control  $\Delta$  /  $\nabla$  /  $\triangleleft$  /  $\triangleright$  buttons work for adjusting the balance. The lamp next to the button lights up.
2. Press Control  $\Delta$  /  $\nabla$  until "BALANCE" appears on the display.
3. Press Control  $\triangleleft$  /  $\triangleright$  to adjust the balance.
  - Pressing Control  $\triangleleft$  decreases the right channel output.
  - Pressing Control  $\triangleright$  decreases the left channel output.

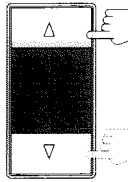
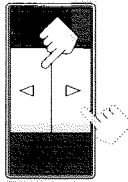

Front panel

See also page 32.

**Listening at Low Volume (Loudness)**

Human ears are not sensitive to bass at low volume. To compensate for this, the loudness function automatically boosts the bass level as you lower the volume.

Note:

The loudness function affects the front speaker sounds only.

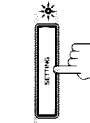

On the front panel only:

1. Press SETTING so that the Control  $\Delta$  /  $\nabla$  /  $\triangleleft$  /  $\triangleright$  buttons work for setting the loudness function. The lamp next to the button lights up.
2. Press Control  $\Delta$  /  $\nabla$  until "LOUDNESS" appears on the display.
3. Press Control  $\triangleleft$  /  $\triangleright$  to set the loudness function to "ON" or "OFF."
  - Select "ON" to activate the loudness function. The LOUDNESS indicator lights up on the display.
  - Select "OFF" to cancel it. The indicator goes off.

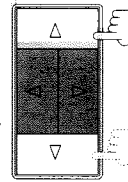
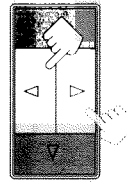

Front panel

See also page 32



**Using the Sleep Timer**

Using the Sleep Timer, you can fall asleep to music and know the receiver will turn off by itself rather than play all night.

**On the front panel:**

1. Press **SETTING** so that the Control  $\Delta / \nabla / \triangleleft / \triangleright$  buttons work for setting the Sleep Timer. The lamp next to the button lights up.
2. Press Control  $\Delta / \nabla$  until "<SLEEP>" appears on the display.

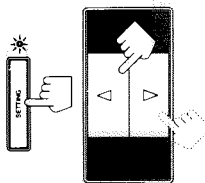

3. Press Control  $\triangleleft / \triangleright$  to set the shut-off time. Each time you press the button, the shut-off time on the display changes as follows: The SLEEP indicator lights up on the display.

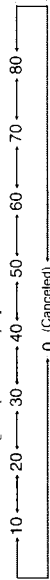

**When the shut-off time comes**

The receiver turns off automatically.

**To check or change the time remaining until the shut-off time**

1. Press **SETTING**, if necessary, so that the Control  $\Delta / \nabla / \triangleleft / \triangleright$  buttons work for setting the Sleep Timer.
2. Press Control  $\Delta / \nabla$ , if necessary, until "<SLEEP>" appears on the display.
3. Press Control  $\triangleleft / \triangleright$  once. The remaining time until the shut-off time appears in minutes.
  - To change the shut-off time, press Control  $\triangleleft / \triangleright$  repeatedly.

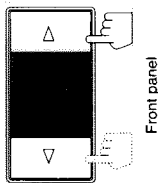

**To cancel the Sleep Timer**

Press Control  $\triangleleft / \triangleright$  repeatedly in step 3 above until "0" appears on the display. (The SLEEP indicator goes off.) Turning off the power also cancels the Sleep Timer.

**From the remote control:**

Press **SLEEP** repeatedly.

The SLEEP indicator lights up and the shut-off time appears on the display. Each time you press the button, the shut-off time on the display changes as follows:



**To check or change the time remaining until the shut-off time**

Press **SLEEP** once. The remaining time until the shut-off time appears in minutes.

- To change the shut-off time, press **SLEEP** repeatedly.

**To cancel the Sleep Timer.**

Press **SLEEP** repeatedly until "0" appears on the display. (The SLEEP indicator goes off.) Turning off the power also cancels the Sleep Timer.

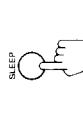

Remote Control

Front panel

See also page 32



**Selecting the Center Speaker Size**

You can register the information on the center speaker after all connections are completed.

If you do this registration first, you do not have to adjust the center speaker mode when you want to activate the Dolby surround. However, to register the information, first you have to set the surround mode either to "PROLOGIC" or "3CHLOGIC." (You cannot select the center speaker size when the surround mode is "SURROFF" or "HALL.")

**On the front panel only:**

1. Press **SURROUND MODE** so that the Control  $\Delta / \nabla$  buttons work for selecting the surround mode. The lamp next to the button lights up.
2. Press Control  $\Delta / \nabla$  until "PROLOGIC" or "3CHLOGIC" whichever you want appears on the display. The PROLOGIC or 3CHLOGIC indicator (as well as the SURROUND indicator) also lights up.
3. Press **SETTING** so that the Control  $\Delta / \nabla / \triangleleft / \triangleright$  buttons work for selecting the center speaker size. The lamp next to the button lights up.
4. Press Control  $\Delta / \nabla$  until "CNTR SPK" (Center Speaker) appears on the display.
5. Press Control  $\triangleleft / \triangleright$  to select the appropriate item about your center speaker. Each time you press the button, the display changes to show the following:
  - LARGE  $\longleftrightarrow$  SMALL  $\longleftrightarrow$  NO

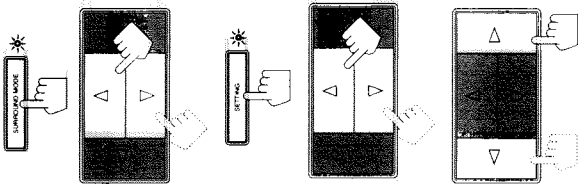

<b>LARGE:</b>	Select this mode when the size of the center speaker is the same as that of the front speakers.
<b>SMALL:</b>	Select this mode when the size of the center speaker is smaller than that of the front speakers.
<b>NO:</b>	Select this mode when you do not use a center speaker. (You cannot select this mode when "3CHLOGIC" is selected for the surround mode.)

**Note:**

This center speaker size setting is so related to the center mode setting for the surround mode that changing this setting affects and changes the center mode to a relevant mode, and vice versa.

For example: "LARGE," the center mode is automatically set to "WIDE," and vice versa.

- If you select "LARGE," the center mode is automatically set to "WIDE," and vice versa.
- If you select "SMALL," the center mode is automatically set to "NORMAL," and vice versa.
- If you select "NO," the center mode is automatically set to "PHANTOM" for Pro Logic, and vice versa.

See also page 32.



**Using Visual Confirmation**

When you operate the receiver, you can see what you are doing, by showing it on the TV screen. To use this function, you need to connect the TV to the MONITOR OUT jack on the rear panel (see page 9), and set the TV's input mode to the proper position to which the receiver is connected. When the TV's input mode is for TV, you cannot see the on-screen display.

**On the front panel only:**

1. Press SETTING so that the Control  $\Delta$  /  $\nabla$  /  $\triangleleft$  /  $\triangleright$  buttons work for setting Visual Confirmation. The lamp next to the button lights up.
2. Press Control  $\Delta$  /  $\nabla$  until "VCONFIRM" appears on the display.
3. Press Control  $\triangleleft$  /  $\triangleright$  to set Visual Confirmation to "ON" or "OFF."
  - Select "ON" to activate Visual Confirmation. The VISUAL CONFIRMATION indicator lights up on the display.
  - Select "OFF" to cancel it. The indicator goes off.

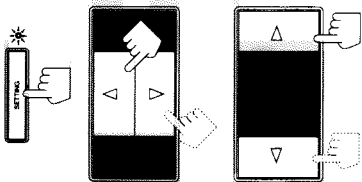

Front panel

**EXAMPLES:**

When changing the source:

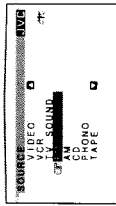

The SOURCE menu appears on the TV screen for about 5 seconds.

When adjusting the front speaker output balance:

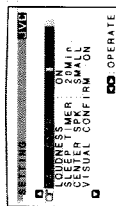

The SETTING menu appears on the TV screen for about 5 seconds.

When selecting your favorite SEA mode:

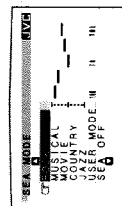

The SEA MODE menu appears on the TV screen for about 5 seconds.

**One Touch Operation**

This receiver can memorize the optimum sound settings for each playing source.

**About the One Touch Operation**

JVC's One Touch Operation function is used to assign and store different sound settings for each different playing source. By using this function, you don't have to change the settings every time you change the source. The stored settings for the newly selected source are automatically recalled.

The following can be stored for each source:

- Volume level (see page 12)
- Balance (see page 14)
- Loudness (see page 14)
- SEA modes (see page 22)
- Surround mode settings (see page 24)

**Note:**

If the source is FM or AM, the One Touch Operation function works only when the preset channels from 1 - 20 are tuned in. You can assign a different setting for each preset channel.

**Using the One Touch Operation**

**To store the sound settings**

1. Press ONE TOUCH OPERATION. The ONE TOUCH OPERATION lamp lights up, then the previously memorized settings are recalled and appear on the display in turn.
2. Adjust the sound using the functions listed above. The newly adjusted settings are memorized.



Front panel

**To recall the sound settings**

With the ONE TOUCH OPERATION lamp lit, the settings for the currently selected source is recalled, and appears on the display when the source is selected.



Remote control

**To cancel the One Touch Operation function**

Press ONE TOUCH OPERATION so that the lamp goes off. (Even though the One Touch Operation function is canceled, the recalled sound effects remain active.)

## Receiving Radio Broadcasts

You can browse through all the stations or use the preset function to go immediately to a particular station.

See also page 33

### Tuning in Stations Manually

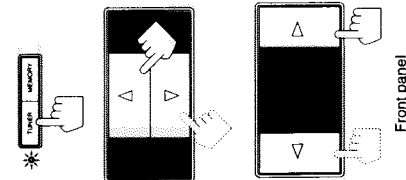

**On the front panel only:**

1. Press **TUNER** so that the Control  $\Delta / \nabla / \triangleleft / \triangleright$  buttons work for tuner settings. The lamp next to the button lights up.
2. Press Control  $\Delta / \nabla$  until "<FM AM>" appears on the display.
3. Press Control  $\triangleleft / \triangleright$  to select the band. Each time you press the button, the band alternates between FM and AM.
4. Press Control  $\Delta / \nabla$  until "<TUNING>" appears on the display.
5. Press Control  $\triangleleft / \triangleright$  until you find the frequency you want.
  - Pressing Control  $\triangleleft$  decreases the frequency.
  - Pressing Control  $\triangleright$  increases the frequency.

**Notes:**

- When you hold down Control  $\triangleleft / \triangleright$  in step 5, the frequency keeps changing until you press the button again or a station is tuned in.
- When a station of sufficient signal strength is tuned in, the TUNED indicator lights up on the display. When an FM stereo program is received, the STEREO indicator also lights up.

See also page 33

### Using Preset Tuning

Once a station is assigned to a channel number, the station can be quickly tuned. You can preset up to 40 stations at random.

**On the front panel only:**

1. **Tune in the station you want to preset** (see above). If you want to store the FM reception mode for this station, select the FM reception mode you want. See page 20 for details.
2. Press **MEMORY** (next to the TUNER button). "CH:" appears and the channel number position starts flashing on the display for about 5 seconds.
3. Press Control  $\Delta / \nabla$  to select a channel number while the channel number position is flashing.
  - Pressing Control  $\Delta$  increases the number.
  - Pressing Control  $\nabla$  decreases the number.

**Note:** You can use the 10 keys on the remote control to select the preset number. When using the 10 keys, be sure that they are activated for tuner, not for the CD and others. (See page 38.)

4. Press **MEMORY** (next to the TUNER button) again while the selected channel number is flashing on the display. The selected channel number stops flashing. The station is assigned to the selected channel number.
5. Repeat steps 1 to 4 until you store all the stations you want.

**To cancel a stored preset station**  
Storing a new station on a used number erases the previously stored one.

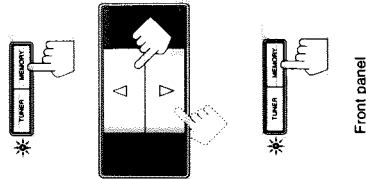

**CAUTION:** Preset stations may be erased when power is cut off to the receiver, as when it is unplugged from the AC outlet or a power failure occurs. If the preset stations are lost, simply set the stations again.

### To tune in a preset station

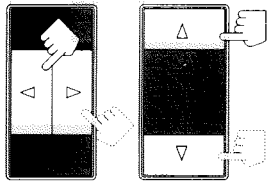
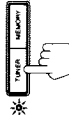

Front panel

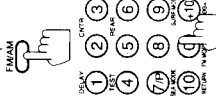

Remote Control

### Selecting the FM Reception Mode

You can change the FM reception mode while listening an FM broadcast. You can also store the FM reception mode for each preset station. (See page 19.)

**On the front panel:**

1. Press **TUNER** so that the Control  $\Delta / \nabla / \triangleleft / \triangleright$  buttons work for tuner settings. The lamp next to the button lights up.
2. Press Control  $\triangleleft / \triangleright$  to select either "FM MODE" appears on the display.
3. Press Control  $\triangleleft / \triangleright$  to select either "AUTO" or "MONO."
  - Normally select "AUTO."
  - When an FM stereo broadcast is hard to receive or noisy, select "MONO."

<b>AUTO:</b>	When a program is broadcast in stereo, you will hear stereo sound; when in monaural, you will hear monaural sounds. This mode is also useful to suppress static noise between stations. The MUTE AUTO indicator lights up on the display.
<b>MONO:</b>	Reception will be improved although you will lose the stereo effect. In this mode, you will hear noise while tuning into the stations. The MUTE AUTO indicator goes off on the display.

**From the remote control:**

Press **FM MODE/MUTE**. Each time you press the button, "AUTO" and "MONO" is alternately selected, and appears on the display.

**Note:** When using the FM MODE/MUTE button, be sure that the 10 keys are activated for tuner, not for the CD and others. (See page 38.)

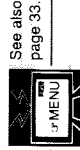

See also page 33

**Assigning Names to Preset Stations**

See also page 33.



You can assign a name of up to five characters to each preset station (from preset channel number 1 to 20). When a preset station is tuned in, its assigned name will appear on the display.

**On the front panel only:**

1. Tune in a preset station (preset channel number 1 to 20). See page 20 for details.

2. Press **MEMORY** (next to the **TUNER** button). The preset channel number starts flashing.

**Note:**  
If you press **Control Δ / ▽** while the preset channel number is flashing, you can change the preset channel number.

3. Press **Control ▷** (or **◁**) until the first character position starts flashing.

4. Press **Control Δ / ▽** to select a character. You can use the characters listed below.

5. When a character you want appears, press **Control ▷** (or **◁**). The next (or previous) character position starts flashing.

6. Repeat steps 4 and 5 to enter up to five characters.

7. Press **MEMORY** (next to the **TUNER** button) again, while the last selected character is flashing, after you have assigned a name.

To erase the input characters  
Insert blanks using the same procedure described above.

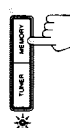
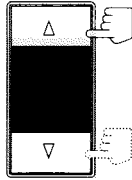
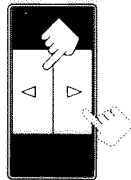
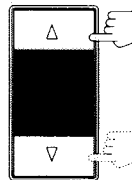
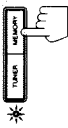

Front panel

Available characters

Blank

A B C D E F G H I J K L M N O  
P Q R S T U V W X Y Z 0 1 2 3 4  
5 6 7 8 9

**Using the SEA Modes**

The SEA (Sound Effect Amplifier) modes give you control of the way your music sounds.

**Note:**  
The SEA modes cannot be used for recording.



See also page 33.

**Selecting Your Favorite SEA Mode**

**On the front panel:**

1. Press **SEA MODE** so that the **Control Δ / ▽** buttons work for selecting the SEA mode. The lamp next to the button lights up.
2. Press **Control Δ / ▽** until the mode you want appears on the display. Each time you press the button, the SEA mode changes as follows:

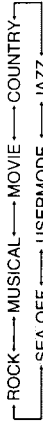

**Note:**  
When the SEA mode is turned on, the SEA indicator lights up on the display.

<b>ROCK:</b>	Gives a heavy sound. Both high and low frequencies are boosted.
<b>MUSICAL:</b>	Enhance the mid-frequency range, which the human voice is mostly made up of. Adds breadth to sounds so you feel like you are in a movie theater.
<b>COUNTRY:</b>	Enhances the high-frequency range so that instruments such the violin and banjo are emphasized.
<b>JAZZ:</b>	Gives a feeling of a live atmosphere. Good for acoustic music.
<b>USERMODE:</b>	Your original SEA adjustment (see page 23).
<b>SEA OFF:</b>	No SEA mode is applied (see below).

To cancel the SEA mode, press **Control Δ / ▽** until "SEA OFF" appears in step 2 above. The SEA indicator goes off from the display.

**From the remote control:**

1. Press the **SOUND CONTROL**. Pressing this button activates the 10 keys for adjusting the sounds.
2. Press the **SEA MODE** button repeatedly until the SEA mode you want appears on the display. Each time you press the button, the SEA mode changes as follows:

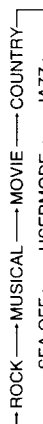

**Note:**  
When the SEA mode is turned on, the SEA indicator lights up on the display.

To cancel the SEA mode, press SEA MODE until "SEA OFF" appears in step 2 above. The SEA indicator goes off from the display.

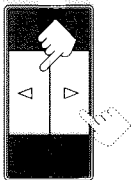
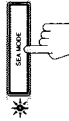

Front panel



Remote Control

### Using the Surround Processor

The built-in surround processor provides three types of surround programs — Dolby Pro Logic, Dolby 3-Channel Logic, and JVC's Hall Surround.

#### What is surround?

The sound heard in a concert hall or a movie theater consists of direct sound and indirect sound: early reflections and reflections from behind. The reflected sounds are always delayed by the distances of the ceiling and walls from the listener. These reflections are some of the most important elements of the acoustic surround.

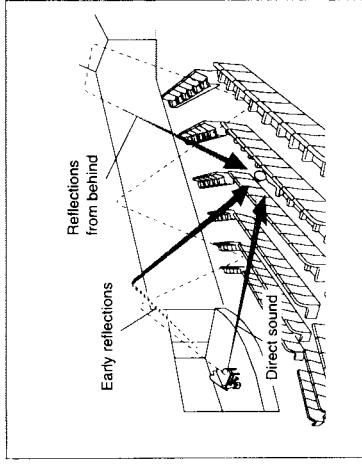

#### On JVC's Hall Surround

In order to reproduce a more realistic sound field in your listening room while playing an ordinary stereo source, JVC's Hall Surround has been designed to give you clear vocals and to create the feeling of a concert hall. The sound is reproduced through the front speakers and rear speakers.

#### On Dolby Surround

Dolby Surround has been also developed to reproduce the important elements of the acoustic surround at home. To watch the soundtracks of video software bearing the mark **DD (Dolby Digital)** \* which includes the same encoded surround information as found in Dolby Stereo films, the receiver can provide you with 2 Dolby Surround programs (Dolby Pro Logic and Dolby 3ch Logic).

**Dolby Pro Logic:** Select this mode when the optional rear speakers are connected (as well as a center speaker).

**Dolby 3ch Logic:** Select this mode when a center speaker is connected without rear speakers.

#### Notes:

- The surround processor has no effect on monaural sources.
- The surround processor cannot be used for recording.

See also page 34.



### Using JVC's Hall Surround

You need to connect one set of rear speakers to obtain the full effect. Once you have adjusted the Hall Surround, the receiver memorizes the settings.

#### On the front panel:

1. Press SURROUND MODE so that the Control  $\Delta / \nabla$  buttons work for selecting the surround modes. The lamp next to the button lights up.
2. Press Control  $\Delta / \nabla$  until "HALL" appears on the display. The HALL and SURROUND indicators also light up on the display. Each time you press the button, the surround modes change as follows (the indicator of the selected surround mode also lights up on the display):

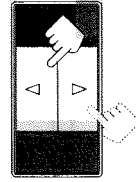
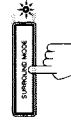

Front panel

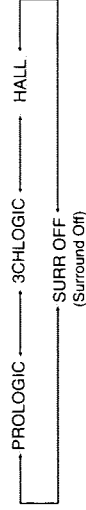

To be continued to the next page

See also page 33.



### Creating Your Own SEA Mode

You can adjust and store your own SEA adjustment into memory (USERMODE).

#### On the front panel only:

If you do not want to store your adjustment, but rather want to adjust the SEA temporarily, skip step 3 below.

1. Press SEA ADJUST so that the Control  $\Delta / \nabla$  /  $\triangleleft$  /  $\triangleright$  buttons work for the SEA adjustment. The lamp next to the button lights up.
2. Adjust the SEA frequency and its level.
  - Press Control  $\triangleleft$  /  $\triangleright$  to select the frequency range to adjust.
  - Press Control  $\Delta$  /  $\nabla$  to adjust the level.

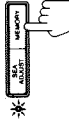
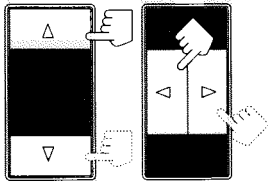
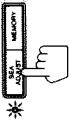

Front panel

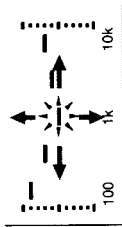

3. Press MEMORY (next to the SEA ADJUST button). Your adjustment is stored into USERMODE.

To recall your own SEA adjustment See page 22.

#### To erase a stored adjustment

Storing a new adjustment into USERMODE erases the previously stored one.

**Speaker arrangements for Dolby Surround**

The following illustrations show how to obtain the optimum sound environment for various Dolby Surround settings. Try to find the speaker direction and location to create the optimum sound field.

**CASE 1** When you have added a center speaker and rear speakers

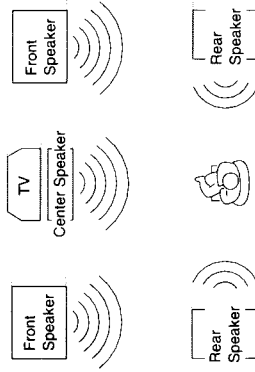

**In this case:**  
 1. Select "PROLOGIC."  
 2. Select "NORMAL" or "WIDE" for center mode.  
 See pages 27 to 29 for more details.

**CASE 2** When you have added rear speakers (without a center speaker)

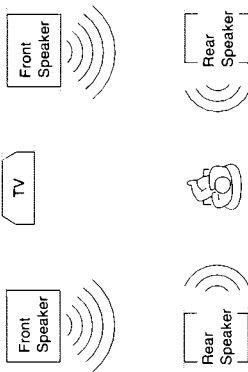

**In this case:**  
 1. Select "PROLOGIC."  
 2. Select "PHANTOM" for center mode.  
 See pages 27 to 29 for more details.

**CASE 3** When you have added a center speaker (without rear speakers)

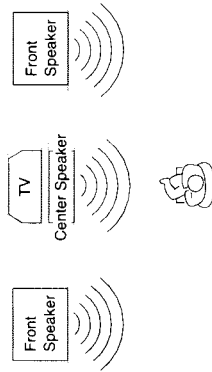

**In this case:**  
 1. Select "3CHLOGIC."  
 2. Select "NORMAL" or "WIDE" for center mode.  
 See pages 27 to 29 for more details.

3. Press SURROUND ADJUST so that the Control  $\Delta / \nabla / \triangleleft / \triangleright$  buttons work for the surround settings.

The lamp next to the button lights up.

4. Press Control  $\Delta / \nabla$  until "- REAR +" appears on the display.

5. Press Control  $\triangleleft / \triangleright$  to adjust the rear speaker output level.

- Pressing Control  $\triangleleft$  decreases the output level up to -10 dB.
- Pressing Control  $\triangleright$  increases the output level up to +10 dB.

6. Press Control  $\Delta / \nabla$  until "-DELAY +" appears on the display.

7. Press Control  $\triangleleft / \triangleright$  to adjust the delay time of the rear speaker output.

Each time you press the button, the delay time changes as follows:

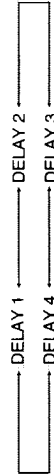

<b>DELAY 1:</b>	Select this when the distance from you to your rear speakers is greater than that to the front speakers.
<b>DELAY 2:</b>	Select this when the distance from you to your rear speakers is almost equal to that to the front speakers.
<b>DELAY 3:</b>	Select this when the distance from you to your rear speakers is a little less than that to the front speakers.
<b>DELAY 4:</b>	Select this when the distance from you to your rear speakers is much less than that to the front speakers.

To cancel the Hall surround, press Control  $\Delta / \nabla$  until "SURR OFF" appears in step 2. The HALL and SURROUND indicators go off.

From the remote control:

1. Press SOUND CONTROL. The remote control is activated for adjusting the sound.
2. Press SURR MODE until "HALL" appears on the display. The HALL and SURROUND indicators also light up on the display. Each time you press the button, the surround modes change as follows (the indicator of the selected surround mode also lights up on the display):

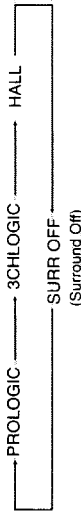

3. Press REAR +/- to adjust the rear speaker output level.

- Pressing REAR - decreases the output level up to -10 dB.
- Pressing REAR + increases the output level up to +10 dB.

4. Press DELAY to adjust the delay time of the rear speaker output.

Each time you press the button, the delay time changes as follows:

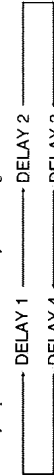

To cancel the Hall Surround, press SURR MODE until "SURR OFF" appears in step 2. The HALL and SURROUND indicators go off.

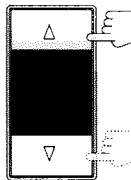
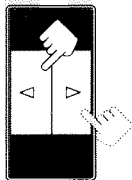

Front panel



Remote Control

**Preparing for Dolby Surround**

See also page 34.

The receiver memorizes two sets of Dolby Surround adjustments, one for Pro Logic and the other for 3ch Logic.

On the front panel:

1. Press **SURROUND MODE** so that the Control  $\Delta / \nabla$  buttons work for selecting the surround modes. The lamp next to the button lights up.

2. Press Control  $\Delta / \nabla$  until "PROLOGIC" or "3CHLOGIC" whichever you want appears on the display. The PRO LOGIC or 3CH LOGIC indicator (as well as the SURROUND indicator) also lights up. Each time you press the button, the surround modes change as follows (the indicator of the selected surround mode also lights up on the display):

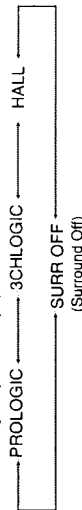

<b>PROLOGIC:</b>	Select this mode to watch a video source with Dolby Surround when you have connected the rear speakers (and a center speaker).
<b>3CHLOGIC:</b>	Select this mode to watch a video source with Dolby Surround when you have connected a center speaker and no rear speakers. This is JVC's original surround mode, and is different from Dolby Surround. To use this, see page 24.
<b>HALL:</b>	No surround mode is applied.
<b>SURR OFF:</b>	No surround mode is applied.

3. Press **SURROUND ADJUST** so that the Control  $\Delta / \nabla / \triangleleft / \triangleright$  buttons work for adjusting the selected surround mode. The lamp next to the button lights up.

4. Press Control  $\Delta / \nabla$  until "CNT MODE" (Center Mode) appears on the display.

5. Press Control  $\triangleleft / \triangleright$  to select the center mode. Each time you press the button, the center modes change as follows:

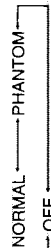

<b>WIDE:</b>	Select this mode when the center speaker can reproduce the bass better than the front speakers. All signals of the center channel are output through the center speaker.
<b>NORMAL:</b>	Select this mode when the center speaker cannot reproduce the bass better than the front speakers. The bass portions of the center channel signals are output through the front speakers.
<b>PHANTOM:</b>	Select this mode when you do not use a center speaker. The center speaker channel signals are output through the front speakers.
<b>OFF:</b>	Select this mode to turn off the center speaker channel.

Notes:

- If you have already set the center speaker size following the procedure described on page 16, you do not have to select the center mode in this procedure.
- When you have selected "3CHLOGIC", you cannot select "PHANTOM."

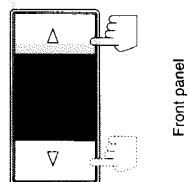
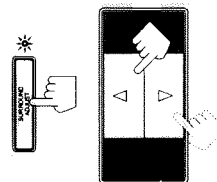
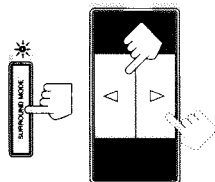

Front panel

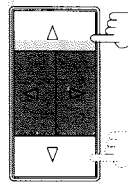
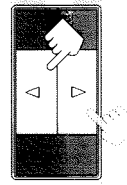
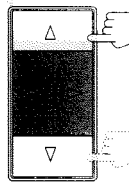
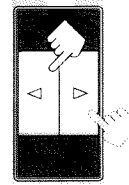
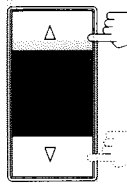
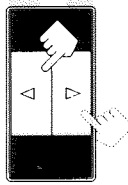

Front panel

6. Press Control  $\Delta / \nabla$  until "DELAY +" appears on the display.

7. Press Control  $\triangleleft / \triangleright$  to adjust the delay time of the rear speaker output. Each time you press the button, the delay time changes as follows:



<b>DELAY 1:</b>	Select this when the distance from you to your rear speakers is greater than that to the front speakers.
<b>DELAY 2:</b>	Select this when the distance from you to your rear speakers is almost equal to that to the front speakers.
<b>DELAY 3:</b>	Select this when the distance from you to your rear speakers is a little less than that to the front speakers.
<b>DELAY 4:</b>	Select this when the distance from you to your rear speakers is much less than that to the front speakers.

Note: When you have selected "3CHLOGIC", you cannot adjust the delay time.

8. Press Control  $\Delta / \nabla$  until "TEST" appears on the display, then press Control  $\triangleleft / \triangleright$  to start checking the speaker output balance. "TEST" starts flashing on the display, and a test tone comes out of the speakers in the following order:

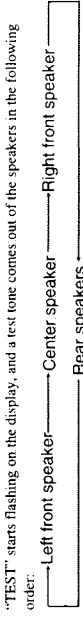

Notes:

- No test tone comes out of the rear speakers when you have selected "3CHLOGIC."
- No test tone comes out of the center speaker when you select "PHANTOM" or "OFF" for the center mode.

9. If necessary, adjust the speaker output balance as follows:

- To adjust the rear speaker output level, press Control  $\Delta / \nabla$  until "REAR +" appears on the display, then press Control  $\triangleleft / \triangleright$ .
- To adjust the center speaker output level, press Control  $\Delta / \nabla$  until "CENTER+" appears on the display, then press Control  $\triangleleft / \triangleright$ .

Notes:

- You cannot adjust the left and right rear speakers output level separately.
- You cannot adjust the rear speakers output level when you have selected "3CHLOGIC."
- You cannot adjust the center speaker output level when you select "PHANTOM" or "OFF" for the center mode.

10. Press Control  $\Delta / \nabla$  until "TEST" appears on the display, then press Control  $\triangleleft / \triangleright$  to stop the test tone.

11. Press Control  $\Delta / \nabla$  until "CNT TONE" (Center Tone) appears on the display.

12. Press Control  $\triangleleft / \triangleright$  to select the center tone you want.

The center tone adjustment affects the mid-frequency range, which the human voice is mostly made up of.

Each time you press the button, the display changes to show the following:

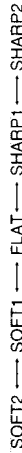

To make the dialogue clearer, select "SHARP1" (little) or "SHARP2" (much). To make the dialogue softer, select "SOFT1" (little) or "SOFT2" (much). When "FLAT" is selected, no adjustment is applied.

Note:

The center tone cannot be adjusted when sounds do not come out of the center speaker.



See also page 34.



**Using Dolby Surround**

Once you have set the Dolby Surround adjustments you can use the same adjustments every time you want to enjoy Dolby Surround. The receiver memorizes two sets of Dolby Surround adjustments, one for Pro Logic and the other for 3ch Logic.

On the front panel:

1. Press **SURROUND MODE** so that the **Control Δ / ▽** buttons work for selecting the surround modes. The lamp next to the button lights up.
2. Press **Control Δ / ▽** until "PROLOGIC" or "3CHLOGIC" whichever you want appears on the display. The PRO LOGIC or 3CH LOGIC indicator (as well as the SURROUND indicator) also lights up. Each time you press the button, the surround modes change as follows (the indicator of the selected surround mode also lights up on the display):

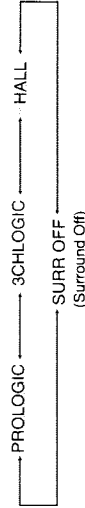

3. Select and play a sound source which was processed with Dolby Surround and is labeled with mark.

To cancel Dolby Surround, press **Control Δ / ▽** until "SURR OFF" appears in step 2 above. The indicator of the selected mode and the SURROUND indicator go off.

From the remote control:

1. Press **SOUND CONTROL**. The remote control is activated for adjusting the sound.
2. If necessary, press **SURR MODE** until "PROLOGIC" or "3CHLOGIC" whichever you want appears on the display. The PRO LOGIC or 3CH LOGIC indicator (as well as the SURROUND indicator) also lights up. Each time you press the button, the surround modes change as follows (the indicator of the selected surround mode also lights up on the display):

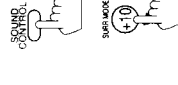

3. Select and play a sound source which was processed with Dolby Surround and is labeled with mark.

To cancel Dolby Surround, press **SURR MODE** until "SURR OFF" appears in step 2 above. The indicator of the selected mode and the SURROUND indicator go off.

From the remote control:

Note: If you want to use the remote control for adjusting the center mode and the center tone, use the menu function (see page 34).

1. Press **SOUND CONTROL**. The remote control is activated for adjusting the sound.
2. Press **SURR MODE** until "PROLOGIC" or "3CHLOGIC" whichever you want appears on the display. The PRO LOGIC or 3CH LOGIC indicator (as well as the SURROUND indicator) also lights up. Each time you press the button, the surround modes change as follows (the indicator of the selected surround mode also lights up on the display):

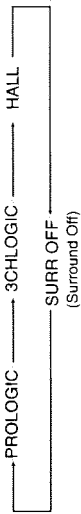

3. Press **DELAY** to adjust the delay time of the rear speaker output. Each time you press the button, the delay time changes as follows:



Note: When you have selected "3CHLOGIC," you cannot adjust the delay time.

4. Press **TEST** to start checking the speaker output balance. "TEST" starts flashing on the display, and a test tone comes out from the speakers in the following order:

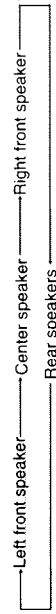

Notes:

- No test tone comes out of the rear speakers when you have selected "3CHLOGIC."
- No test tone comes out of the center speaker when you select "PHANTOM" or "OFF" for the center mode.

5. If necessary, adjust the speaker output balance as follows:

- To adjust the rear speaker output level, press **REAR +/-**.
- To adjust the center speaker output level, press **CNTR +/-**.

Pressing - decreases the output level up to -10 dB.  
Pressing + increases the output level up to +10 dB.

- Notes:
- You cannot adjust the left and right rear speakers output level separately.
  - You cannot adjust the rear speakers output level when you have selected "3CHLOGIC."
  - You cannot adjust the center speaker output level when you select "PHANTOM" or "OFF" for the center mode.

6. Press **TEST** again to stop the test tone.

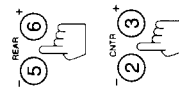
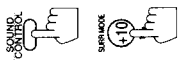

Remote Control

### Using the On-Screen Display to Control the Receiver

You can use the menu function on the TV screen to control the receiver. To use this function, you need to connect the TV to the MONITOR OUT jack on the rear panel (see page 9), and set the TV's input mode to the appropriate position to which the receiver is connected. When the TV's input mode is for TV, you cannot see the on-screen display.

**IMPORTANT:**  
When you use the menu functions, make sure that you have connected a TV and operate the menu function while watching the on-screen displays on the TV.

From the remote control:

- Press MENU:**
  - If you press  $\Delta/\nabla/\leftarrow/\rightarrow$  a sub-menu you can adjust at that time appears on the TV screen instead of the MAIN MENU.
- Press  $\Delta/\nabla$  to move  $\square$  to the sub-menu you want to set, then press  $\leftarrow/\rightarrow$ .**  
The sub-menu you want appears.
- If necessary, press  $\Delta/\nabla/\leftarrow/\rightarrow$  to set or adjust the item you want on the selected sub-menu.**  
When a item is selected, the item will be highlighted.

**Note:**  
Moving  $\square$  to an item does not mean that you have selected it. If the item is not highlighted, press  $\leftarrow/\rightarrow$  to highlight it.

- When you finish, press MENU EXIT.**  
The menu disappears from the TV.

To go back to the MAIN MENU any time during the process  
Press MENU again.

#### Menu function buttons

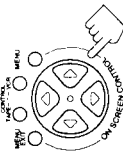

#### MAIN MENU

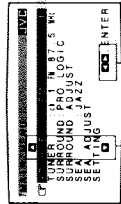

Shows the buttons you can use on the current menu. In this case, press  $\Delta/\nabla$  to move  $\square$  up and down, and  $\leftarrow/\rightarrow$  to select the item. (The menus are shown on the TV for about one minute.)

#### ■ Selecting the Source to Play (Also see page 11)

- Press MENU.**  
The MAIN MENU appears on the TV.
- Press  $\Delta/\nabla$  to move  $\square$  to "SOURCE," then press  $\leftarrow/\rightarrow$ .**  
The SOURCE menu appears.
- Press  $\Delta/\nabla$  to move  $\square$  to the source you want to play.**
- When you finish, press MENU EXIT.**  
The menu disappears from the TV.

#### SOURCE menu

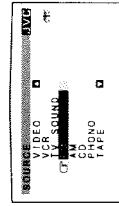

#### ■ Adjusting the Front Speaker Output Balance (Also see page 14)

- Press MENU.**  
The MAIN MENU appears on the TV.
- Press  $\Delta/\nabla$  to move  $\square$  to "SETTING," then press  $\leftarrow/\rightarrow$ .**  
The SETTING menu appears.
- Press  $\Delta/\nabla$  to move  $\square$  to "BAL." (Balance).**
- Press  $\leftarrow/\rightarrow$  repeatedly to adjust the balance.**
- When you finish, press MENU EXIT.**  
The menu disappears from the TV.

#### SETTING menu

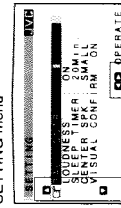

Shows the buttons you can use on the current menu. In this case, press  $\Delta/\nabla$  to move  $\square$  up and down, and  $\leftarrow/\rightarrow$  to adjust or set the item.

#### ■ Listening at Low Volume [Loudness] (Also see page 14)

- Press MENU.**  
The MAIN MENU appears on the TV.
- Press  $\Delta/\nabla$  to move  $\square$  to "SETTING," then press  $\leftarrow/\rightarrow$ .**  
The SETTING menu appears.
- Press  $\Delta/\nabla$  to move  $\square$  to "LOUDNESS."**
- Press  $\leftarrow/\rightarrow$  to set the loudness function to "ON" or "OFF."**
- When you finish, press MENU EXIT.**  
The menu disappears from the TV.

#### SETTING menu

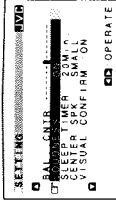

#### ■ Using the Sleep Timer (Also see page 15)

- Press MENU.**  
The MAIN MENU appears on the TV.
- Press  $\Delta/\nabla$  to move  $\square$  to "SETTING," then press  $\leftarrow/\rightarrow$ .**  
The SETTING menu appears.
- Press  $\Delta/\nabla$  to move  $\square$  to "SLEEP TIMER."**
- Press  $\leftarrow/\rightarrow$  to set the shut-off time.**
- When you finish, press MENU EXIT.**  
The menu disappears from the TV.

#### SETTING menu

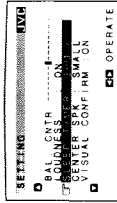

#### ■ Selecting the Center Speaker Size (Also see page 16)

**Note:**  
When the surround mode is *Hall* or *off*, you cannot select the center speaker size.

- Press MENU.**  
The MAIN MENU appears on the TV.
- Press  $\Delta/\nabla$  to move  $\square$  to "SETTING," then press  $\leftarrow/\rightarrow$ .**  
The SETTING menu appears.
- Press  $\Delta/\nabla$  to move  $\square$  to "CENTER SPK." (Center Speaker).**
- Press  $\leftarrow/\rightarrow$  repeatedly until the appropriate center speaker size is selected.**
- When you finish, press MENU EXIT.**  
The menu disappears from the TV.

#### SETTING menu

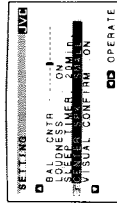

#### ■ Using Visual Confirmation (Also see page 17)

- Press MENU.**  
The MAIN MENU appears on the TV.
- Press  $\Delta/\nabla$  to move  $\square$  to "SETTING," then press  $\leftarrow/\rightarrow$ .**  
The SETTING menu appears.
- Press  $\Delta/\nabla$  to move  $\square$  to "VISUAL CONFIRM." (Visual Confirmation).**
- Press  $\leftarrow/\rightarrow$  to set Visual Confirmation to "ON" or "OFF."**
- When you finish, press MENU EXIT.**  
The menu disappears from the TV.

#### SETTING menu

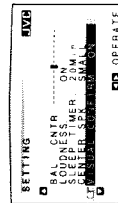

**Operating the Tuner**

1. Press **MENU**.  
The MAIN MENU appears on the TV.
2. Press  $\Delta / \nabla$  to move  $\square$  to "TUNER," then press  $\triangleleft / \triangleright$ .  
The TUNER menu appears.
3. Press  $\Delta / \nabla$  to move  $\square$  to the item you want to set or adjust, then press  $\triangleleft / \triangleright$ .  
On the TUNER menu, you can do the following:  
 "CH": Select a preset channel station. (See page 20)  
 "BAND": Select a preset channel station. (See page 20)  
 "TUNING": Select the band. (See page 19)  
 "FM MODE": Select the FM reception mode. (See page 20)  
 "FM MODE": Select the FM reception mode. (See page 20)
4. When you finish, press **MENU EXIT**.  
The menu disappears from the TV.

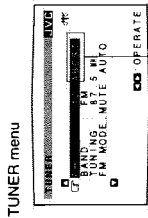

If you have assigned the name to this preset station, it appears here.

**Selecting Your Favorite SEA Mode** (Also see page 22)

1. Press **MENU**.  
The MAIN MENU appears on the TV.
2. Press  $\Delta / \nabla$  to move  $\square$  to "SEA," then press  $\triangleleft / \triangleright$ .  
The SEA MODE menu appears.
3. Press  $\Delta / \nabla$  to move  $\square$  to the SEA mode you want.
4. When you finish, press **MENU EXIT**.  
The menu disappears from the TV.

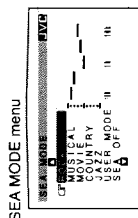

**Creating Your Own SEA Mode** (Also see page 23)

1. Press **MENU**.  
The MAIN MENU appears on the TV.
2. Press  $\Delta / \nabla$  to move  $\square$  to "SEA ADJUST," then press  $\triangleleft / \triangleright$ .  
The SEA ADJUST menu appears.
3. Press  $\Delta / \nabla$  /  $\triangleleft / \triangleright$  to adjust the SEA mode as you want.  
 $\triangleleft / \triangleright$ : Select the frequency ranges.  
 $\Delta / \nabla$ : Adjust the frequency levels.
4. Press **MEMORY** (next to the SEA ADJUST button).
5. When you finish, press **MENU EXIT**.  
The menu disappears from the TV.

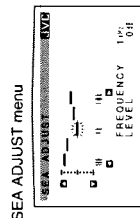

**Selecting the Surround Modes** (Also see pages 24)

1. Press **MENU**.  
The MAIN MENU appears on the TV.
2. Press  $\Delta / \nabla$  to move  $\square$  to "SURROUND," then press  $\triangleleft / \triangleright$ .  
The SURROUND MODE menu appears.
3. Press  $\Delta / \nabla$  to move  $\square$  to one of the surround modes.  
If you want to adjust the selected mode, go to the following steps.
4. Press **MENU**.  
The MAIN MENU appears on the TV again.
5. Press  $\Delta / \nabla$  to move  $\square$  to "SURROUND ADJUST," then press  $\triangleleft / \triangleright$ .  
The adjustment menu for the mode you have selected in step 3 appears.
6. Press  $\Delta / \nabla$  to move  $\square$  to the item you want to set or adjust, then press  $\triangleleft / \triangleright$ .  
On these adjustment menus, you can do the following:

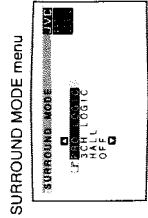

**HALL** adjustment menu

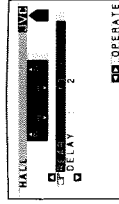

- "REAR": Adjust the rear speaker output level.
- "DELAY": Adjust the delay time of the rear speaker sound.

**For Dolby Pro Logic:**

- "CENTER MODE": Select the center mode.
- "TEST": Output a test tone.
- "CENTER": Adjust the center speaker output level.
- "REAR": Adjust the rear speaker output level.
- "DELAY": Adjust the delay time of the rear speaker sound.
- "CENTER TONE": Select the center tone.

**PRO LOGIC** adjustment menu



**For Dolby 3ch Logic:**

- "CENTER MODE": Select the center mode.
- "TEST": Output a test tone.
- "CENTER": Adjust the center speaker output level.
- "CENTER TONE": Select the center tone.

**3CH LOGIC** adjustment menu



7. When you finish, press **MENU EXIT**.  
The menu disappears from the TV.

**COMPU LINK Remote Control System**

The COMPU LINK remote control system allows you to operate JVC audio components through the remote sensor on the receiver. To use this remote control system, you need to connect JVC audio components through the COMPU LINK-3 (SYNCHRO) jacks (see below) in addition to the connections using cables with RCA pin plugs (see page 8).

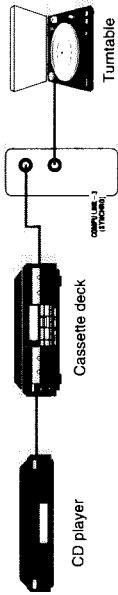

**Notes:**

- If your audio component has two COMPU LINK-3 (SYNCHRO) jacks, you can use either one. If it has only one COMPU LINK-3 (SYNCHRO) jack, connect it so that it is the last item in the series of components. (For example, the turntable or CD player in the diagram above.)
- Refer also to the manuals supplied with your audio components.

This remote control system allows you to use four functions listed below.

**Remote Control through the Remote Sensor on the Receiver**

You can control the connected audio components through the remote sensor on the receiver using this remote control. For details, see pages 38 and 39.

**Note:**  
Aim the remote control directly at the remote sensor on the receiver.

**Automatic Source Selection**

When you press the play (▶) button on a connected component or on its own remote control, the receiver automatically turns on and changes the source to the component. On the other hand, if you select a new source on the receiver or the remote control, the selected component begins playing immediately. In both cases, the previously selected source continues playing without sound for a few seconds.

**Automatic Power On/Off (only possible with the COMPU LINK-3 connection)**

Both the CD player and cassette deck turn on and off along with the receiver. When you turn on the receiver, the CD player or cassette deck will turn on automatically, depending on which component has been previously selected. When you turn off the receiver, both the CD player and cassette deck will turn off.

**Synchronized Recording**

Synchronized recording means the cassette deck starts recording as soon as a CD or a record begins playing.

To use synchronized recording, follow these steps:

- 1 Put a tape in the cassette deck, and a disc in the CD player (or a record on the turntable).
- 2 Press the record (●) button and the pause (II) button on the cassette deck at the same time. This puts the cassette deck into recording pause.

**Note:**  
If you do not press the record (●) button and pause (II) button at the same time, the synchronized recording feature will not operate.

**Press the play (▶) button on the CD player or on the turntable.**

The source changes on the receiver, and as soon as play starts, the cassette deck starts recording. When the play ends, the cassette deck enters recording pause, and stops about 4 seconds later.

**Notes:**

- During synchronized recording, the selected source cannot be changed.
- If your CD player is playing in program mode, a 4-second blank is recorded between tracks so that the music scan feature of your cassette deck can be used on the recorded tape.
- If the power of any component is shut off during synchronized recording, the COMPU LINK remote control system may not operate properly. In this case, you must start again from the beginning.

**AV COMPU LINK Remote Control System**

The AV COMPU LINK remote control system allows you to operate JVC video components (TV and VCR) through the receiver.

**CONNECTIONS:**

To use this remote control system, you need to connect the video components you want to operate, following the procedures below.

**CAUTION:**  
The AV COMPU LINK remote control system cannot control the video components connected to the VIDEO jacks on the receiver. Use only VCR jacks for the VCR jacks.

1. Connect your VCR and TV as follows, using the cables with the monaural mini-plugs (not supplied).

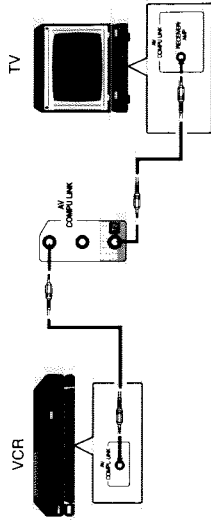

2. Connect the VCR and TV as follows.

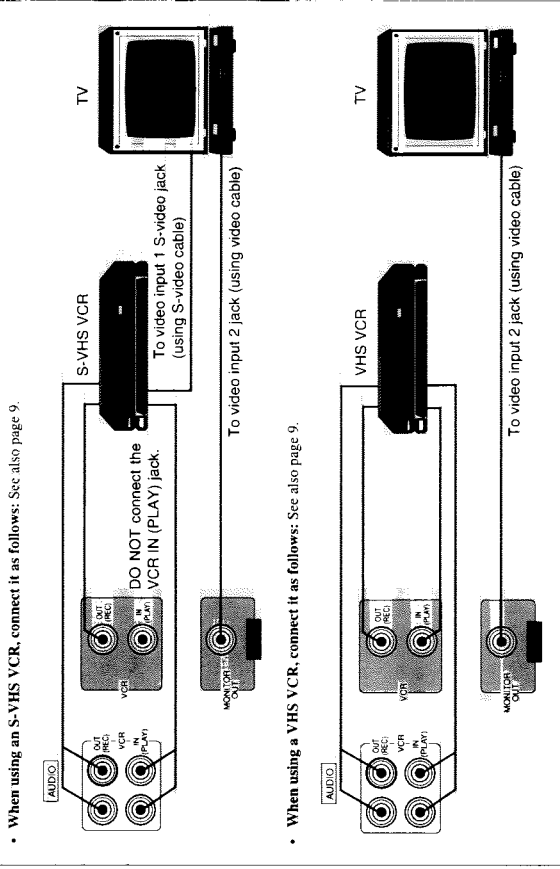

- When using an S-VHS VCR, connect it as follows: See also page 9.

- When using a VHS VCR, connect it as follows: See also page 9.

3. When turning on the TV for the first time after the AV COMPU LINK connection, turn the TV volume to the minimum using the TV volume control on the TV.

## Using the Remote Control for Operating JVC's Audio/Video Components

This remote control system allows you to use four functions listed below.

**Note:**  
Refer also to the manuals supplied with your video components.

### ■ Remote Control of the TV through the Remote Sensor on the Receiver

You can control the TV through the remote sensor on the receiver using this remote control. For details, see page 39.

**Note:**

Aim the remote control directly at the remote sensor on the receiver when operating the TV. (However, to operate the VCR, always aim the remote control directly at the remote sensor on the VCR.)

### ■ One-Touch Video Play

Simply by inserting a video cassette without its safety tab into the VCR, you can enjoy the video playback without setting other switches manually.

The receiver automatically turns on and changes the source to "VCR".  
The TV automatically turns on and changes the input mode to the position you can view the VCR playback. When you insert a video cassette with its safety tab, press the play (▶) button on the VCR or on the remote control. So, you can get the same result.

**Note:**

When you connect an S-VHS VCR as described on page 36, you cannot see the on-screen displays (such as Visual Confirmation and Menus) since the AVCOMPULINK Remote Control System automatically changes the TV input mode to "Video input 1" when you operate the S-VHS VCR. If you do not mind stopping watching the picture, you can then show the on-screen displays after changing the TV input mode to the position (Video input 2) the receiver is connected to.

### ■ Automatic Selection of TV's Input Mode

- When you select "TV SOUND" as the source to play on the receiver, the TV automatically changes the input mode to the TV tuner so that you can watch TV.
- When you select "VIDEO" as the source to play on the receiver, the TV automatically changes the input mode to the Video Input 2 so that you can watch the playback picture.
- When you select "VCR" as the source to play on the receiver, the TV automatically changes the input mode to the correct position (either Video Input 1 or 2) so that you can watch the playback picture.

**Note:**

When you select "TV SOUND" as the source on the receiver, you cannot see the on-screen displays (such as Visual Confirmation and the menu function) since the AVCOMPULINK remote control system automatically changes the TV input mode to the TV tuner. If you do not mind stopping listening to the TV sounds, you can then show the on-screen displays after changing the TV input mode to the position (Video input 2) the receiver is connected to.

### ■ Automatic Power On/Off

The TV and VCR turn on and off along with the receiver. When you turn on the receiver.

- If the previously selected source is "VCR", the TV and VCR will turn on automatically.
- If the previously selected source is "VIDEO" or "TV SOUND", only the TV will turn on automatically. When you turn off the receiver, the TV and VCR will turn off.

**Note:**

If you turn off the receiver while recording on the VCR, the VCR will not turn off, but continue recording.

You can operate JVC's audio and video components with this receiver's remote control, since control signals for JVC components are preset in the remote control.

**Notes:**

- If you use the buttons on the front panel or the menu function to choose a source, the remote control will not operate that source. To operate a source with the remote control, the source must be selected using buttons on the remote control.
- Check to see if its remote control mode selector is set to the correct position. To operate audio system, TVs, and VCRs, set it to the "AUDIO/TV/VCR" position.
- Refer also to the manuals supplied with your components.

### IMPORTANT:

To operate JVC's audio components using this remote control:

- You need to connect JVC audio components through the COMPU LINK-3 (SYNCHRO) jacks (see page 35) in addition to the connections using cables with RCA pin plugs (see page 8).
- Aim the remote control directly at the remote sensor on the receiver.

### Tuner

After pressing FM/AM (with the remote control mode selector set to the "AUDIO/TV/VCR" position), you can perform the following operations:

**FM/AM:** Alternates between FM and AM.

**1 — 10, +10:** Selects a preset channel number directly.

For channel number 5, press 5. For channel number 15, press +10, then 5. For channel number 20, press +10, then 10.

**FM MODE/MUTE:** Changes the FM reception mode.

### Sound control section (Amplifier)

After pressing SOUND CONTROL (with the remote control mode selector set to the "AUDIO/TV/VCR" position), you can perform the following operations:

**SEA MODE:** Changes the SEA modes.

**SURR MODE:** Changes the surround modes.

**ENTR +/-:** Changes the center speaker output level for the surround modes.

**REAR +/-:** Changes the left/right rear speaker output level for surround modes.

**DELAY:** Changes the delay time for surround modes.

**TEST:** Checks the speaker output level for surround modes.

**Note:**

After adjusting sounds, press the corresponding source selecting button (FM/AM, CD, CD TRACK, CD/DISC, VCR or TV SOUND) to operate your target source by using 10 keys; otherwise, 10 keys cannot be used for operating your target source.

### CD player

After pressing CD or CD TRACK (with the remote control mode selector set to the "AUDIO/TV/VCR" position), you can perform the following operations on a CD player:

**PLAY:** Starts playing.

**▶▶:** Returns to the beginning of the current (or previous) track.

**▶:** Skips to the beginning of the next track.

**⏸:** Stops playing. To release it, press PLAY.

**PAUSE:** Pauses playing. To release it, press PLAY.

**1 — 10, +10:** To select track number 5, press 5. For track number 15, press +10, then 5. For track number 20, press +10, then 10. For track number 30, press +10, +10, then 10.

**Note:**

You can use either the CD button or the CD TRACK button to activate the buttons listed above. If you press CD, the playing source also changes to "CD." On the other hand, if you press CD TRACK, the playing source does not change to "CD."

### CD player-changer

After pressing CD/DISC (with the remote control mode selector set to the "AUDIO/TV/VCR" position), you can perform the following operations on a CD player-changer:

**PLAY:** Starts playing.

**▶▶:** Returns to the beginning of the current (or previous) track.

**▶:** Skips to the beginning of the next track.

**⏸:** Stops playing. To release it, press the PLAY button.

**PAUSE:** Pauses playing. To release it, press the PLAY button.

**1 — 6, 7/P:** Select the number of a disc installed in a CD player-changer.

After pressing CD TRACK:

**1 — 10, +10:** Selects a track number directly.

To select track number 5, press 5. For track number 15, press +10, then 5. For track number 20, press +10, then 10. For track number 30, press +10, +10, then 10.

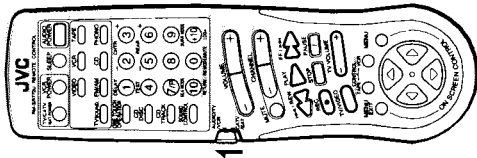

### Operating Other Manufacturers' VCR, TV, CATV Converter, and Satellite Tuners

This remote control supplied with the receiver can transmit control signals for other manufacturers' VCRs, TVs and CATV converters. By changing the transmittable signals from preset ones to the other manufacturers', you can operate the other manufacturer's components using this remote control.

When operating the other manufacturers' components, refer also to the manuals supplied with them. To operate these components with the remote control, first you need to set the manufacturer's code each for VCR, TV, CATV converters, and satellite tuner.

#### IMPORTANT

When using the Remote Control, check to see if its remote control mode selector is set to the correct position:  
**To operate an audio system, TV, and VCR,** set it to the "AUDIO/TV/VCR" position.  
**To operate a CATV converter and satellite tuner,** set it to the "CATV/SAT" position.



To change the transmittable signals for operating another manufacturer's TV

1. Set the remote control mode selector to the "AUDIO/TV/VCR" position.
2. Press and hold TV/CATV/SAT POWER.
3. Press TV SOUND.

4. Enter the manufacturer's code (three digits) using buttons 1 - 9, and 0. See the lists on page 42 to find the code.

5. Release TV/CATV/SAT POWER.

The following buttons can be used for operating the TV (with the remote control mode selector set to the "AUDIO/TV/VCR" position):

**TV/CATV/SAT POWER:** Turns on and off TV.

After pressing TV SOUND you can perform the following operations on the TV:

**CHANNEL +/-:** Changes the channels.

**TV VOLUME +/-:** Adjusts the volume.

**1 - 10, 0, +10:** Selects the TV channels.

**+10 button** will function as the ENTER button if your TV requires pressing ENTER after selecting a channel number.

**TV/VIDEO:** Sets the input mode (either TV or VIDEO).

**Note:** Refer also to the manual supplied with your TV.

**Try to operate your TV by pressing TV/CATV/SAT POWER.**

When your TV turns on or off, you have entered the correct code.

**If there are more than one code listed for your brand of TV, try each one until the correct one is entered.**

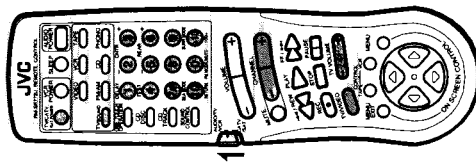

#### Turntable

After pressing PHONO (with the remote control mode selector set to the "AUDIO/TV/VCR" position), you can perform the following operations on a turntable:

**PLAY:** Starts playing.

**STOP:** Stops playing.

#### Cassette deck

After pressing TAPE or TAPE CONTROL (with the remote control mode selector set to the "AUDIO/TV/VCR" position), you can perform the following operations on a cassette deck:

**PLAY:** Starts playing.

**REW:** First rewinds the tape from right to left.

**FF:** First rewinds the tape from left to right.

**STOP:** Stops operations.

**PAUSE:** Pauses playing or recording temporarily. To release it, press the PLAY button.

**REC:** Press this button with the PLAY button to start recording.

Press this button with the PAUSE button to enter recording pause (standby).

**Note:** You can use either the TAPE button or the TAPE CONTROL button to activate the buttons listed above. If you press TAPE, the playing source also changes to "TAPE." On the other hand, if you press TAPE CONTROL, the playing source does not change to "TAPE."

#### IMPORTANT:

- You need to connect JVC video components using this remote control: in addition to the connections using cables with RCA pin plugs (see pages 9 and 36).
- When operating the VCR, aim the remote control directly at the remote sensor on the VCR.
- When operating the TV, aim the remote control directly at the remote sensor on the receiver.

#### VCR

After pressing VCR or VCR CONTROL (with the remote control mode selector set to the "AUDIO/TV/VCR" position), you can perform the following operations on the VCR:

**PLAY:** Starts playing.

**REW:** Rewinds a tape.

**FF:** Fast winds a tape.

**STOP:** Stops operations.

**PAUSE:** Pauses playing or recording temporarily. To release it, press the PLAY button.

**REC:** Press this button with the PLAY button to start recording.

Press this button with the PAUSE button to enter recording pause (standby).

**CHANNEL +/-:** Changes the channels on the VCR.

**1 - 9, 0:** Selects the channels on the VCR.

#### Notes:

- You can use either the VCR button or the VCR CONTROL button to activate the buttons listed above. If you press VCR, the playing source also changes to "VCR." On the other hand, if you press VCR CONTROL, the playing source does not change to "VCR."
- You can also turn the VCR on and off by pressing VCR POWER on the remote control.

#### TV

After pressing TV SOUND (with the remote control mode selector set to the "AUDIO/TV/VCR" position), you can perform the following operations on a TV:

**CHANNEL +/-:** Changes the channels.

**TV VOLUME +/-:** Adjusts the volume.

**1 - 9, 0, 100+:** Selects the channels.

**TV/VIDEO:** Sets the input mode (either TV or VIDEO).

**RETURN:** Alternates between the previously selected channel and the current channel.

#### Note:

You can also turn the TV on and off by pressing TV/CATV/SAT POWER on the remote control.

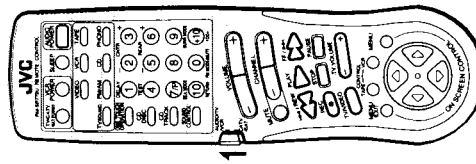

To change the transmittable signals for operating a CATV converter or satellite tuner

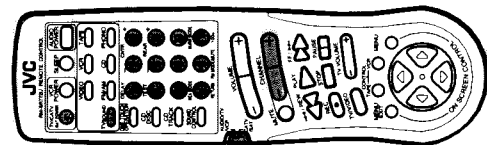

1. Set the remote control mode selector to the "CATV/SAT" position.
  2. Press and hold TV/CATV/SAT POWER.
  3. Press TV SOUND.
  4. Enter the manufacturer's code (three digits) using buttons 1 - 9, and 0. See the lists on page 43 to find the code.
  5. Release TV/CATV/SAT POWER. After setting the remote control mode selector to the "CATV/SAT" position, you can perform the following operations on the CATV converter or on the satellite tuner:  
**TV/CATV/SAT POWER:** Turns on and off the CATV converter or satellite tuner.  
**CHANNEL +/-:** Changes the channels.  
**1 - 10, 0, +10:** Selects the channels. +10 button will function as the ENTER button if your CATV converter or satellite tuner requires pressing ENTER after selecting a channel number.
- Note:*  
Refer also to the manual supplied with your CATV converter or satellite tuner.
6. Try to operate your CATV converter or satellite tuner by pressing TV/CATV/SAT POWER. When your CATV converter or satellite tuner turns on or off, you have entered the correct code.
  7. If there are more than one code listed for your brand of CATV converter or satellite tuner, try each one until the correct one is entered.

To change the transmittable signals for operating another manufacturer's VCR

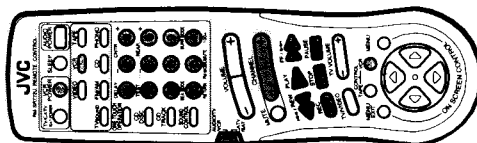

1. Set the remote control mode selector to the "AUDIO/TV/VCR" position.
  2. Press and hold VCR POWER.
  3. Press VCR.
  4. Enter the manufacturer's code (three digits) using buttons 1 - 9, and 0. See the lists on page 44 to find the code.
  5. Release VCR POWER. The following buttons can be used for operating the VCR:  
**VCR POWER:** Turns on and off VCR.  
**VCR CONTROL:** After pressing VCR or VCR CONTROL (with the remote control mode selector set to the "AUDIO/TV/VCR" position), you can perform the following operations on the VCR:  
**CHANNEL +/-:** Changes the channels on the VCR.  
**1 - 10, 0, +10:** Selects the channels on the VCR. +10 button will function as the ENTER button if your VCR requires pressing ENTER after selecting a channel number.  
**PLAY:** Starts playback.  
**STOP:** Stops operations.  
**PAUSE:** Pauses.  
**REW:** Rewinds a tape.  
**FF:** Fast winds a tape.  
**REC:** Starts recording or enters recording pause.
- Notes:*
- You can use either the VCR button or the VCR CONTROL button to activate the buttons listed above.
  - If you press VCR, the playing source also changes to "VCR." On the other hand, if you press VCR CONTROL, the playing source does not change to "VCR."
  - Refer also to the manual supplied with your VCR.
6. Try to operate your VCR by pressing VCR POWER. When your VCR turns on or off, you have entered the correct code.
  7. If there are more than one code listed for your brand of VCR, try each one until the correct one is entered.

Manufacturers' codes for TV

Admiral	093	Majestic	016
Adventura	046	Marantz	030, 054
Aiko	092	Matsushita	250
Akai	030	Megatron	145, 178
Alleron	179	Memorex	016, 056, 150, 154, 178
Ambassador	177	MGA	019, 030, 150, 178
Anam	180	Midland	017, 039, 047, 051, 135
Anam National	055	Minutz	021
AOC	019, 030	Mitsubishi	019, 093, 150, 178
Audiovox	180	Motorola	055, 093
Belcor	019	MTC	019, 030, 056, 060
Bell & Howell	016, 154	Multitech	180
Bradford	180	NAD	156, 166, 178
Brockwood	019	NEC	019, 030, 056
Candle	030, 046, 056	Nikko	030, 092, 178
Carnivale	030	Noshi	018
Carver	054	NTC	092
Celebrity	000	Onwa	180
Citizen	030, 039, 046, 056, 060, 092, 280	Optimus	154, 166, 250
Concerto	056	Optonica	093, 165
Contec	180	Orion	236
Craig	180	Panasonic	051, 055, 250
Crown	039, 180	Penney	018, 019, 021, 030, 039, 047, 051, 060,
Curtis Mathes	030, 039, 060, 154		135, 149, 156, 178
CXC	180	Philco	019, 020, 030, 054
Daewoo	019, 039, 092, 451	Philips	054
Daytron	019	Pilot	019, 030, 039
Dumont	017, 019	Pioneer	166
Electrobond	000	Portland	019, 039, 092
Emerson	019, 039, 154, 177, 178, 179, 180, 236, 280, 292, 463	Prism	051
Envision	030	Proscan	047
Fisher	154, 159	Proton	178
Fujitsu	179	Pulsar	017, 019
Funai	171, 179, 180	Quasar	051, 055, 165, 250
Futuretech	180	Radio Shack	019, 030, 039, 047, 056, 154, 165, 178, 180
GE	021, 047, 051, 055, 135, 178, 282, 451	RCA	018, 019, 047, 090, 135
Gibraller	017, 019, 030	Realistic	019, 030, 039, 056, 154, 165, 178, 180
GoldStar	019, 030, 039, 056, 178	Runco	017, 030
Grundy	179, 180	Sampo	030, 039
Hallmark	179	Samsung	019, 030, 039, 056, 060, 178
Harvard	180	Samsux	039
Hitachi	056, 145, 151	Sanyo	154, 159
Infinity	054	Scimitu	019
Janeli	046	Scotch	178
JBL	054	Scott	019, 178, 179, 180, 236
JCB	000	Sears	047, 054, 056, 149, 154, 156, 159, 171, 178, 179
JVC	053, 069, 160, 169	Sharp	039, 093, 165
KEC	180	Shogun	019
Kenwood	019, 030	Signature	016
Kloss	046	Simpson	187
KTV	030, 039, 180, 280	Sony	000
Logik	016	Soundesign	178, 179, 180
Luxman	056	Squareview	171
LXI	047, 054, 154, 156, 178	SSS	019, 180
Magnavox	020, 030, 054, 187		

Manufacturers' codes for CATV converters		Manufacturers' codes for satellite tuner		Manufacturers' codes for VCR	
Starlite	180	AlphaStar	772	Admiral	048
Supre-Macy	046	EchoStar	775	Adventura	000
Supreme	000	General Instrument	361	Aiko	278
Sylvania	020, 030, 054	HITS	775	Aiwa	000
Symphonic	171	Hughes Network Systems	749	Akal	041
Tandy	093	Jerrold	361	American High	035
Tatung	055	Panasonic	701	Asha	240
Technics	051, 250	PrimeStar	361	Audiovox	037
Technol Ace	179	RCA	566	Beaumont	240
Techwood	051, 056	Sony	639	Bell & Howell	104
Teknika	016, 019, 039, 054, 056, 060, 082, 150, 179, 180			Bell & Howell	104
TMK	056, 177, 178			Broksonic	121, 184, 211
Toshiba	060, 149, 154, 156			Calix	037
Television	039			Canon	035
Vector Research	030			Capehart	020
Victor	053			Carver	081
Vidkron	054			CCE	072, 278
Vidtech	019, 178			Citizen	037, 278
Viking	046			Colt	072
Wards	016, 019, 020, 021, 030, 054, 056, 165, 178, 179			Craig	037, 047, 072, 240
Yamaha	019, 030			Curtis Mathes	035, 041, 060
Zenith	016, 017			Cybernex	240
				Daewoo	020, 045, 278
				Daytron	020
				Dynatech	000
				Electrohome	037
				Electrohome	037
				Emerex	032
				Emerson	000, 002, 037, 043, 121, 184, 211, 212, 278, 479
				Fisher	047, 054, 104
				Fuji	033, 035
				Funai	000
				Garrard	000
				GE	035, 060
				GoldStar	037, 038
				Gradiente	000
				Harley Davidson	000
				Harman/Kardon	038
				Harwood	072
				Headquarter	046
				Hi-Q	047
				Hitachi	041, 042, 105
				Jensen	041
				JVC	008, 041, 067
				KEC	037, 278
				Kenwood	038, 041, 067
				KLH	072
				Kodak	035, 037
				Lloyd	000
				Logik	072
				LXI	037
				Magnavox	035, 039, 081, 149
				Magnin	240
				Marantz	035, 081
				Marta	037
				Matsushita	035, 162
				MEI	035
				Memorex	000, 035, 037, 039, 046, 047, 048, 104, 240
				MGA	043
				MGN Technology	240
				Minolta	042, 105
				Mitsubishi	043, 067
				Motorola	035, 048
				MTC	000, 240
				Multitech	000, 072
				NEC	038, 041, 067, 104
				Nikko	037
				Nikon	034
				Noblex	240
				Olympus	035
				Optimus	037, 048, 104, 162
				Optonica	062
				Orion	479
				Panasonic	035, 162, 225
				Penney	035, 037, 038, 042, 054, 240
				Pentax	042, 105
				Philco	035
				Philips	035, 062, 081
				Pilot	037
				Pioneer	067
				Portland	020
				Profitronic	240
				Protec	072
				Pulsar	039
				Quarter	046
				Quartz	046
				Quasar	035, 162
				Radio Shack	000, 037
				Radix	037
				Randex	037
				RCA	042, 060, 105, 149
				Realistic	000, 035, 037, 046, 047, 048, 062, 104
				Ricoh	034
				Runco	039
				Samsung	045, 240



**Troubleshooting**

Use this chart to help you solve daily operational problems. If there is any problem you cannot solve, contact your JVC service center.

PROBLEM	POSSIBLE CAUSE	SOLUTION
The display does not light up.	The power cord is not plugged in.	Plug the power cord into an AC outlet.
No sound from speakers.	Speaker signal cables are not connected. The SPEAKERS 1 and 2 buttons are not set correctly. An incorrect source is selected. Mute is activated.	Check speaker wiring and reconnect if necessary. Press SPEAKERS 1 and 2 correctly. Select the correct source. Press MUTE to cancel the mute.
Sound from one speaker only.	Speaker signal cables are not connected properly. The balance is set to one extreme.	Check speaker wiring and reconnect if necessary. Adjust the balance properly.
Continuous hiss or buzzing during FM reception.	Incoming signal is too weak. The station is too far away. An incorrect antenna is used. Antennas are not connected properly.	Connect an outside FM antenna or contact your dealer. Select a new station. Check with your dealer to be sure you have a correct antenna. Check connections.
Occasional crackling noise during FM reception.	Ignition noise from automobiles.	Move the antenna farther from automobile traffic.
No colors on the on-screen display.	The color system of the connected TV is not NTSC.	Connect an NTSC TV.
Howling during record playing.	Your turntable is too close to speakers.	Move speakers away from the turntable.
Remote control does not work.	The remote control mode selector is not set correctly. There is an obstruction in front of the remote control sensor on the receiver. Batteries are weak.	Set the selector correctly either to the "AUDIO/TV/CR" position or to "CATV/SAT" position. Remove the obstruction. Replace batteries.

Sanky	039, 048
Sansui	041, 067
Sanyo	046, 047, 104, 240
Scott	043, 045, 121, 184, 211, 212
Sears	035, 037, 042, 046, 047, 054, 104, 105
Sharp	048, 062
Shinrom	072
Shogun	240
Singer	072
Sony	032, 033, 034, 035
STS	042
Sylvania	000, 035, 043, 081
Symphonic	000
Tatung	041
Teac	000, 041
Technics	035, 162
Teknika	000, 035, 037
TMK	240
Toshiba	043, 045, 212
Television	037, 240
Unittech	240
Vector	045
Vector Research	038
Video Concepts	045
Videosonic	240
Wards	000, 035, 042, 047, 048, 060, 062, 072, 149, 212, 240
XR-1000	000, 035, 072
Yamaha	038
Zenith	033, 034, 039

Manufacturers' codes listed on page 42 to 45 are subject to change without notice. If they are changed, this remote control cannot operate the equipment.

**Specifications**

**Amplifier**

Output Power At Stereo operation  
 At Surround operation Front Channels  
 Center channel  
 Rear channels

**110 watts per channel, min. RMS, both channels driven into 8 ohms, 20 Hz to 20 kHz with no more than 0.06 % total harmonic distortion.**

110 watts per channel, min. RMS, driven into 8 ohms at 1 kHz with no more than 0.8 % total harmonic distortion.  
 110 watts, min. RMS, driven into 8 ohms at 1 kHz, with no more than 0.8 % total harmonic distortion.  
 110 watts, min. RMS, driven into 8 ohms at 1 kHz, with no more than 0.8 % total harmonic distortion.

Total Harmonic Distortion (8 ohms, 1 kHz)  
 0.06 %\* at 110 watts output  
 (\* Measured by JVC Audio Analysis System)

Audio Input Sensitivity/Impedance (1 kHz)  
 PHONO (MM)  
 CD, TAPE, TV SOUND, VCR, VIDEO

2.5 mV/47 k ohms  
 230 mV/47 k ohms

Audio Output Level  
 TAPE, VCR

230 mV

Signal-to-Noise Ratio ('66 IHF/78 IHF)  
 PHONO  
 CD, TAPE, TV SOUND, VCR, VIDEO

70 dB/78 dB (at REC OUT)  
 87 dB/80 dB

Frequency Response (8 ohms)  
 PHONO  
 CD, TAPE, TV SOUND, VCR, VIDEO

20 Hz to 20 kHz (±1 dB)  
 20 Hz to 20 kHz (±1 dB)

RIAA Phono Equalization

±0.5 dB (20 Hz to 20 kHz)

Loudness Control (Volume Control at -40 dB)

+6 ±1 dB at 100 Hz  
 +4 ±1 dB at 10 kHz

S.E.A.

100 Hz, 1 kHz, 10 kHz  
 ±10 dB ±2 dB

**Video**

Video Input Sensitivity/Impedance  
 VCR, VIDEO

1 V<sub>p</sub>-p/75 ohms

Video Output Level  
 VCR, MONITOR OUT

1 V<sub>p</sub>-p/75 ohms

Synchronization

Negative

Signal-to-Noise Ratio

45 dB

On-Screen Color System

NTSC

**F.M. tuner (IHF)**

Tuning Range  
 87.5 MHz to 108.0 MHz

Usable Sensitivity  
 10.8 dBf (0.95 μV/75 ohms)

50 dB Quieting Sensitivity  
 16.3 dBf (1.8 μV/75 ohms)  
 38.3 dBf (22.5 μV/75 ohms)

Signal-to-Noise Ratio (IHF-A weighted)  
 80 dB at 85 dBf  
 73 dB at 85 dBf

Total Harmonic Distortion  
 0.15 % at 1 kHz  
 0.2 % at 1 kHz

Stereo Separation at REC OUT  
 40 dB at 1 kHz

Capture Ratio  
 1.5 dB (10 mV)

Alternate Channel Selectivity  
 60 dB (±100 kHz)

Frequency Response  
 30 Hz to 15 kHz: (+0.5 dB, -3 dB)

**A.M. tuner**

Tuning Range  
 530 kHz to 1,710 kHz

Usable Sensitivity  
 300 μV/m  
 30 μV

Signal-to-Noise Ratio  
 50 dB (100 mV/m)

**General**

Power Requirements  
 AC 120V, 60 Hz

Power Consumption  
 300 watts/400 V A  
 2 watts (in standby mode)

Dimensions (W x H x D)  
 17 1/16 x 6 7/16 x 16 1/4 inches  
 (435 x 156.5 x 412 mm)

Mass  
 22.3 lbs (10.1 kg)

Designs & specifications are subject to change without notice.

# Description of Major LSIs

## ■ MN101C01DAC (IC401) : System controller

### 1. Terminal Layout

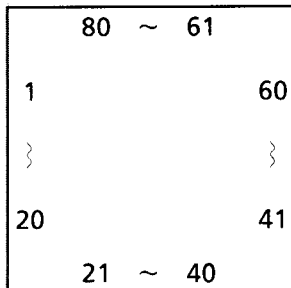

### 2. Description

Pin No.	Symbol	I/O	Description	Pin No.	Symbol	I/O	Description
1		--	Not used	45	SEADATA	O	Data to IC551
2	VCR S/C	I	VCR composite detect signal	46	SEACLK	O	Clock to IC551
3~10		--	Not used	47	4/8Ω SELLECT	O	4/8Ω select signal output
11	VDD	--	Power supply	48	4/8Ω DETECT	I	4/8Ω detect signal input
12	OSC2	--	Oscillation terminal	49		--	Not used
13	OSC1	--	Oscillation terminal	50	SURRSTB	O	Strobe signal to IC601
14	VSS	--	GND	51		--	Not used
15	X1	--	GND	52	M/CS	O	Chip select to IC411
16	X0	--	Not used	53	MRESET	O	Reset signal to IC411
17		--	GND	54	MDO	O	Command data to IC411
18	DATA	O	Data to IC321,IC305,IC307,IC601	55	MDI	I	Status signal from IC411
19		--	Not used	56	MCLK	O	Clock to IC411
20	CLK	O	Clock to IC321,IC305,IC307,IC601	57		--	Not used
21~23		--	Not used	58	SVOLSTB	O	Strobe signal to IC307
24	SURON/OFF	O	Surround ON/OFF control	59	FVOLSTB	O	Strobe signal to IC305
25	RESET	I	Reset signal input	60	ASWSTB	O	Strobe signal to IC321
26	TCE	O	Chip enable output for IC102	61	SMUTE	O	Source mute control
27	TCK	O	Clock signal output for IC102	62~64	CENT3~1	O	Center level control signal
28	IFDATA	I	Data signal from IC102	65	TUN/MEMI	O	TUN/MEMORY indication control
29	TDATA	O	Data signal for IC102	66	SEAADJ/MEMI	O	SEAADJ/MEMORY indication control
30	TMUTE	O	Tuner mute control signal	67	SEAI	O	SEA MODE indication control
31	TUNED	I	TUNED signal input	68	SETI	O	SETTING indication control
32	STEREO	I	STEREO signal input	69	ADJI	O	SURROUND ADJ indication control
33		--	GND	70	SURI	O	SURROUND MODE indication control
34	MBUSY	I	Busy signal from IC411	71		--	Not used
35	INHIN	I	Inhibit signal input	72	TAPE/VCRI	O	TAPE/VCR indication control
36	OSD DATA	O	Data for IC203	73	PHONOI	O	PHONO indication control
37	OSD STB	O	Chip select signal for IC203	74	CDI	O	CD indication control
38	OSD CLK	O	Clock output for IC203	75	AMI	O	AM indication control
39~40	VIDEO1~2	O	VIDEO SELECT signal output	76	FMI	O	FM indication control
41	VIDEOON/OFF	O	VIDEO ON/OFF signal to IC221	77	TVSOUNDI	O	TV SOUND indication control
42		--	Not used	78	VCRI	O	VCR indication control
43		--	Not used	79	VIDEO2I	O	VIDEO2 indication control
44	VL/VH	O	RY881 control signal	80	VIDEO1I	O	VIDEO1 indication control

## ■ MN171602JAAN (IC411) : FL & System controller

### 1. Terminal Layout

VDD	1	64	OSC1
S16	2	63	OSC2
S15	3	62	VSS
S14	4	61	X2
S13	5	60	X1
S12	6	59	KI0
S11	7	58	KI1
S10	8	57	KI2
S9	9	56	KI3
S8	10	55	ONEI
S7	11	54	DVDMULTI
S6	12	53	STANDBYI
S5	13	52	
S4	14	51	TVC
S3	15	50	TVO
S2	16	49	VCRO
S1	17	48	DCSOUT
VPP	18	47	DCSIN
1G/KO0	19	46	VCRI
2G/KO1	20	45	RMI
3G/KO2	21	44	M/CS
4G/KO3	22	43	MRESET
5G/KO4	23	42	STATUS
6G	24	41	COMMAND
7G	25	40	MCLK
8G	26	39	MBUSY
9G/KO5	27	38	JOG1
10G	28	37	JOG2
11G	29	36	POWER
12G	30	35	17G
13G	31	34	16G
14G	32	33	15G

MN171602JAAN

### 2. Key Matrix

	KEY IN 0 (PIN59)	KEY IN 1 (PIN58)	KEY IN 2 (PIN57)	KEY IN 3 (PIN56)
KEY OUT 0 (PIN19)	POWER (S401)	--	ONE TOUCH OPERATION (S403)	--
KEY OUT 1 (PIN20)	SEA MEMORY (S405)	SURROUND (S406)	ADJUST (S407)	SETTING (S408)
KEY OUT 2 (PIN21)	↑ (S409)	→ (S410)	SOURCE (S411)	SEA (S412)
KEY OUT 3 (PIN22)	↓ (S413)	← (S414)	SEA ADJUST (S415)	TUNER (S416)
KEY OUT 4 (PIN23)	TUNER MEMORY (S417)	—	—	—

### 3. Description

Pin No.	Symbol	I/O	Description	Pin No.	Symbol	I/O	Description
1	V <sub>DD</sub>	--	Power supply	45	RMI	I	Remote signal input
2~17	S16~S1	O	Segment control signal	46	VCR IN	I	AV compulink
18	V <sub>PP</sub>	--	Power supply	47	DCS IN	I	Compulink signal input
19~23	1G/KO0~ 5G/KO4	O	Grid control signal / Key matrix output	48	DCS OUT	O	Compulink signal input
24~26	6G~8G	O	Grid control signal	49	VCR OUT	O	AV compulink
27~28	9G/KO5~ 10G/KO6	O	Grid control signal / Key matrix output	50	TVO	O	AV compulink
29~35	11G~17G	O	Grid control signal	51	TVC	O	AV compulink
36	POWER	O	POWER ON/OFF control	52		--	Non connection
37	JOG2	I	Input 2 of JOG pulse	53	STANDBYI	O	STANDBY LED control signal
38	JOG1	I	Input 1 of JOG pulse	54		--	Non connection
39	MBUSY	O	Busy signal to IC401	55	ONEI	O	ONE TOUCH LED control signal
40	MCLK	I	Clock to IC401	56~59	KI3~KI0	I	Key matrix Input
41	MDI	I	Command data from IC401	60	X1		GND
42	MDO	O	Status signal to IC401	61	X2	--	Not used
43	MRESET	I	Reset signal from IC401	62	VSS	--	GND
44	M/CS	I	Chip select RX-882/RX-992	63,64	OSC2,OSC1	--	Oscillation terminal

■ LC72131 (IC102) : PLL Synthesizer

1. Terminal Layout

XIN	1	22	XOUT
	2	21	VSS
PLLCE	3	20	LPF OUT
PLLDA	4	19	LPF IN
PLLCK	5	18	PD
IFDATA	6	17	VDD
$\overline{\text{FM}}$	7	16	FM OSC
$\overline{\text{MW}}$	8	15	AM OSC
$\overline{\text{LW}}$	9	14	
AUTO/MONO	10	13	IF REQ
POWER	11	12	FM/AM IF

2. Block Diagram

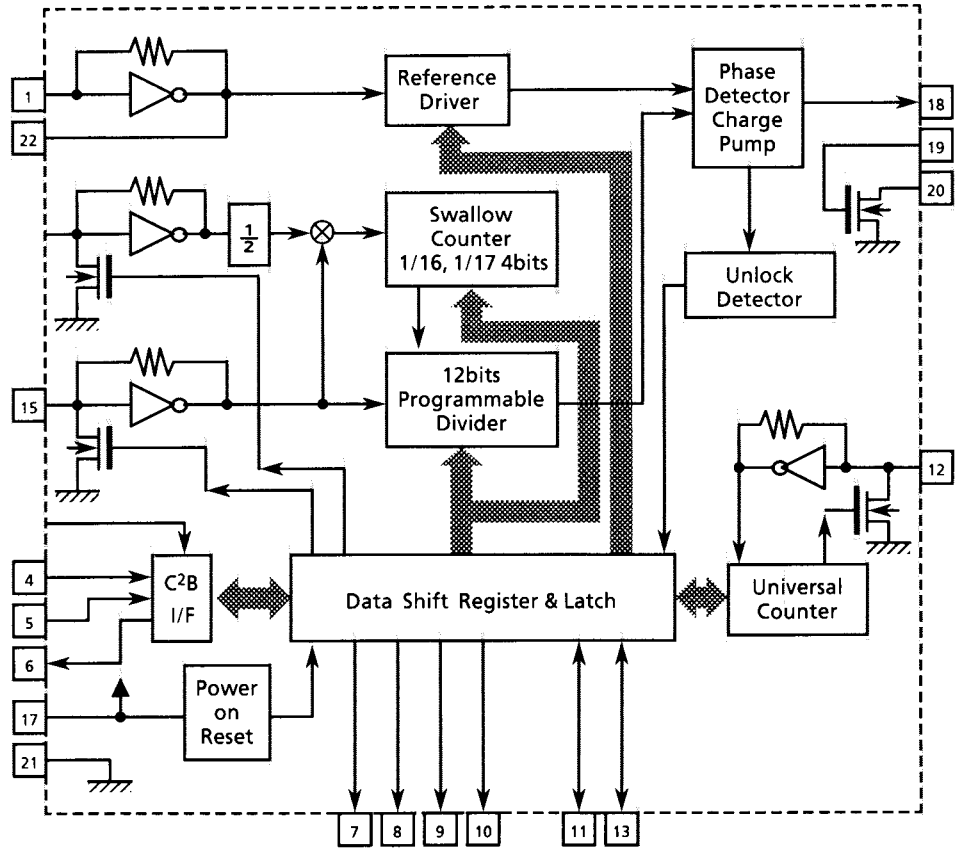

3. Pin Functions

Pin No.	Symbol	I/O	Functions	Pin No.	Symbol	I/O	Functions
1	X in	I	Crystal oscillator (7.2MHz).	12	FM/AM IF	I	Universal counter input
2		--	Not use	13	IF REQ	O	Output the "IF-signal request" to IC102
3	PLLCE	I	Fix the chip enable to "H" when inputting(DI) and outputting (DO) the serial data	14		I	Not use
4	PLLDA	I	Receive the control data from the controller (IC201).	15	AMOSC		Input the local oscillator signal of AM.
5	PLLCK	I	This clock is used to synchronize data when transmitting the data of DI and DO.	16	FM OSC	I	Input the local oscillator signal of FM.
6	IFDATA	O	Transmit the data from LC72131 to the controller which is synchronized with CK.	17	VDD	O	This is a terminal of power supply.
7	$\overline{\text{FM}}$	O	It is "L" on FM mode.	18	PD	O	PLL charge pump output : When the local oscillator signal frequency is higher than the reference frequency high level signals will output. When it is lower than the reference frequency, low level signals will output. When it is same as reference frequency signals, it will be floating.
8	$\overline{\text{MW}}$	O	It is "L" on MW mode.	19	LPF IN	I	Transistor used for the PLL active low-pass filter
9	$\overline{\text{LW}}$	O	It is "L" on LW mode.	20	LPF OUT	O	Transistor used for the PLL active low-pass filter
10	AUTO/MONO	O	It is "L" on monaural, "H" on auto.	21	VSS	--	Connected to GND
11	POWER	O	Regulator control singal PON "H", STANDBY "L"	22	X out	O	Crystal oscillator (7.2MHz).

■ LA1837 (IC102) : FM AM IF AMP & detector, FM MPX Decoder

1. Block Diagram

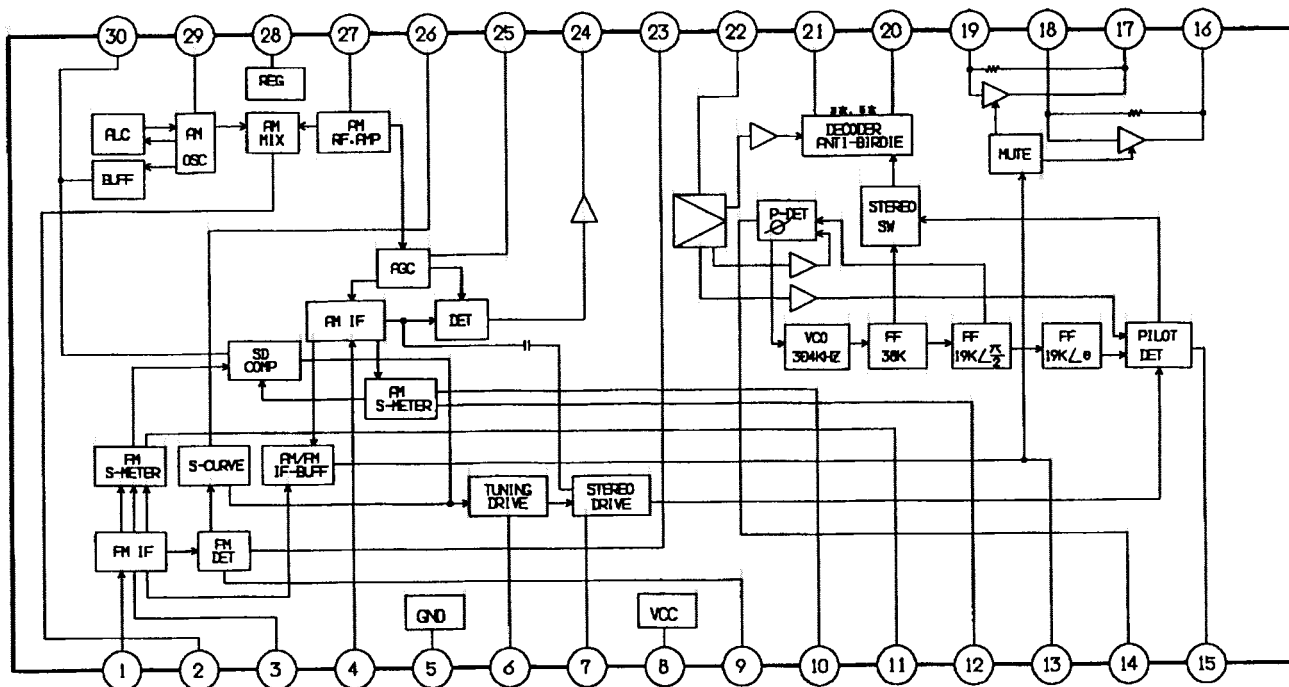

3. Pin Function

Pin No.	Symbol	I/O	Function	Pin No.	Symbol	I/O	Function
1	FM IN	I	This is an input terminal of FM IF Signal.	16	L OUT	O	Left channel signal output.
2	AM MIX	O	This is an output terminal for AM mixer.	17	R OUT	O	Right channel signal output
3	FM IF	I	Bypass of FM IF	18	L IN	I	Input terminal of the Left channel post AMP.
4	AM IF	I	Input of AM IF Signal.	19	R IN	I	Input terminal of the Right channel post AMP.
5	GND	—	This is the device ground terminal.	20	RO	O	Mpx Right channel signal output.
6	TUNED	O	When the set is tuning ,this terminal becomes "L".	21	LO	O	Mpx Left channel signal output.
7	STEREO	O	Stereo indicator output. Stereo : "L", Mono : "H"	22	IF IN	I	Mpx input terminal.
8	VCC	—	This is the power supply terminal.	23	FM OUT	O	FM detection output.
9	FM DET	—	FM detect transformer.	24	AM DET	O	AM detection output.
10	AM SD	—	This is a terminal of AM ceramic filter.	25	AM AGC	I	This is an AGC voltage input terminal for AM.
11	FM VSM	O	Adjust FM SD sensitivity.	26	AFC	—	This is an output terminal of voltage for FM-AFC.
12	AM VSM	O	Adjust AM SD sensitivity.	27	AM RF	I	AM RF signal input.
13	MUTE	I/O	When the signal of IF REQ of IC121( LC72131 ) appear, the signal of FM/AM IF output. //Muting control input.	28	REG	O	Register value between pin26 and pin28 desides the frequency width of the input signal.
14	FM/AM	I	Change over the FM / AM input. "H" : FM, "L" : AM	29	AM OSC	—	This is a terminal of AM Local oscillation circuit.
15	MONO/ST	O	Stereo : "H", Mono : "L"	30	OSC BUFFER	O	AM Local oscillation Signal output.

## ■ LA2786 (IC601) : Dolby Pro Logic Surround Signal Processor

### 1. Terminal Layout

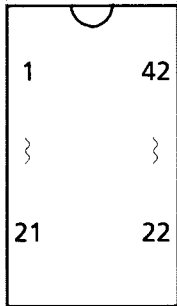

### 2. Pin Functions

Pin No	Symbol	I/O	Functions	Pin No	Symbol	I/O	Functions
1	NS-BPF1	--	Capacitor for spectrum filter in noise sequencer	22	VCS-1	--	Capacitor for time constant (in log differential area)
2	NS-BPF2	--	Capacitor for spectrum filter in noise sequencer	23	VCS-2	--	Capacitor for time constant (in log differential area)
3	VREF	--	Analog reference voltage	24	VCS-TH	--	Capacitor for time constant (in log differential area)
4	S-DC-OUT	--	Capacitor for DC-cut Sch	25	L+R RECT	--	Capacitor for Center channel detection
5	C-DC-OUT	--	Capacitor for DC-cut Cch	26	DC-CUT	--	Capacitor for DC-cut at detection circuit
6	L-DC-OUT	--	Capacitor for DC-cut Lch	27	L-R RECT	--	Capacitor for Surround channel detection
7	R-DC-OUT	--	Capacitor for DC-cut Rch	28	DC-CUT	--	Capacitor for DC-cut at detection circuit
8	VREF-BUFFER	--	VREF low impedance	29	R-BPF3	--	LPF,HPF for Right channel control circuit
9	L-IN	I	Left channel signal input	30	R-BPF2	--	LPF,HPF for Right channel control circuit
10	R-IN	I	Right channel signal input	31	R-BPF1	--	LPF,HPF for Right channel control circuit
11	GND	--	Ground	32	C-TRIM DC-CUT	--	Capacitor for DC-cut Center channel
12	L-BPF1	--	LPF,HPF for Lch control circuit	33	C-MODE-CAP	--	Capacitor for Center channel output low-pass filter
13	L-BPF2	--	LPF,HPF Left channel control circuit	34	C-OUT	O	Center signal output
14	L-BPF3	--	LPF HPF Left channel control circuit	35	S-OUT	O	Surround signal output
15	DC-CUT	--	Capacitor for DC-cut at detection circuit	36	R-OUT	O	Right channel signal output
16	R RECT	--	Capacitor for Right channel detection	37	L-OUT	O	Left channel signal output
17	DC-CUT	--	Capacitor for DC-cut at detection circuit	38	VCC	--	power supply
18	L RECT	--	Capacitor for Left channel detection	39	OSC	--	Oscillation for noise sequencer and auto balance
19	VLR-TH	--	Capacitor for time constant (in log differential area)	40	STB	I	Strobe signal input
20	VLR-2	--	Capacitor for time constant (in log differential area)	41	DATA	I	Serial interface data input
21	VLR-1	--	Capacitor for time constant (in log differential area)	42	CLK	I	Serial interface clock

■ LV1016 (IC641) : Dolby Surround Passive Decoder

1. Terminal Layout

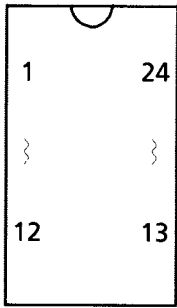

2. Block Diagram

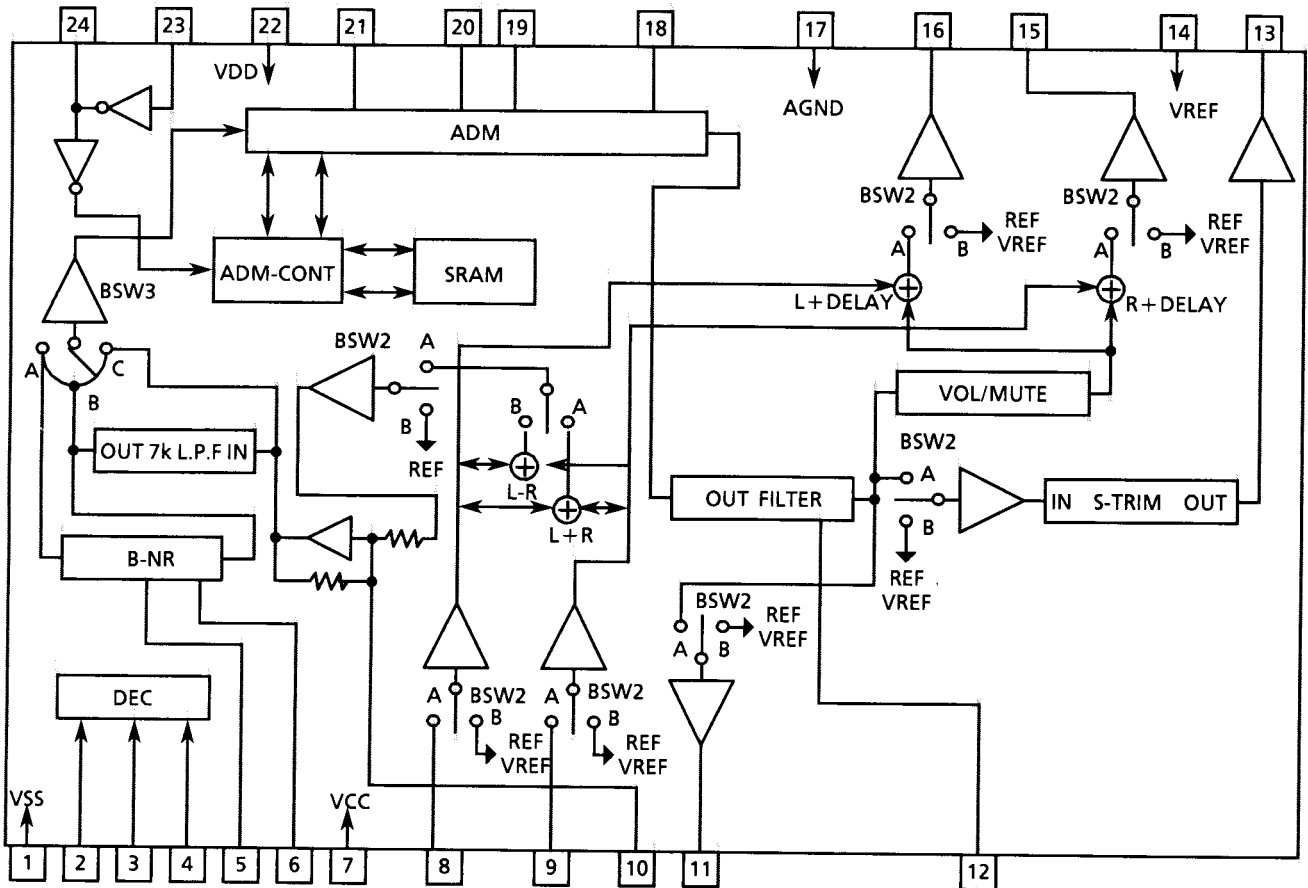



## 3. Pin Functions

Pin No.	Symbol	I/O	Functions
1	DGND	--	Digital GND
2	CLK	I	Serial interface clock
3	DATA	I	Serial interface data input
4	STB	I	Strobe signal input
5	NR-DET	--	Capacitor for noise reduction detection
6	NR-IREF	--	Resistor for noise reduction reference current
7	VCC	--	Supply
8	L-IN	I	Left channel signal input
9	R-IN	I	Right channel signal input
10	S-IN	I	Surround signal input
11	DELAY-OUT	--	Not used
12	DC-CUT	--	Capacitor for DC-cut
13	S-OUT	O	Surround signal output
14	VREF	--	Analog reference voltage
15	R-MIX-OUT	--	Not used
16	L-MIX-OUT	--	Not used
17	ADND	--	Analog ground
18	DC-CUT	--	Capacitor for DC-cut
19	D/A	--	Capacitor for integrator
20	NOISE SHAPER	--	Capacitor for noise shaper
21	A/D	--	Capacitor for integrator
22	VDD	--	Supply for the digital section
23	OSC	--	Oscillation terminal
24	OSC	--	Oscillation terminal

■ LC7522 (IC551) : Variable Resistor for SEA Control

1. Terminal Layout      2. Block Diagram

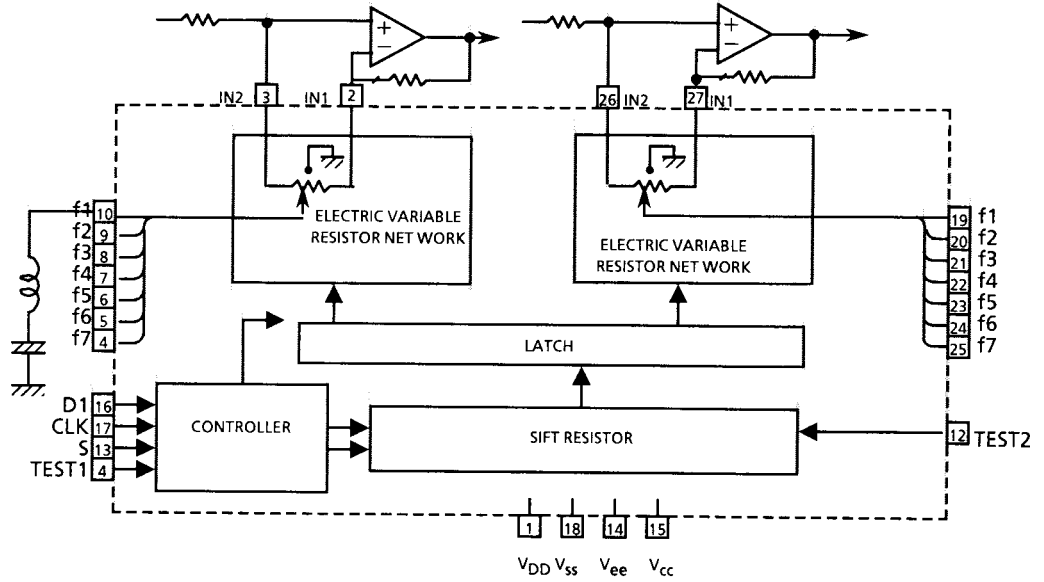
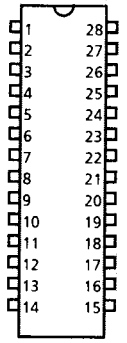

3. Pin Functions

Pin No.	Pin Name	Functions
1	V <sub>DD</sub>	Power supply +7V for audio signal
18	V <sub>SS</sub>	Ground.
14	V <sub>EE</sub>	Power supply -7V for audio signal.
15	V <sub>CC</sub>	Power supply +5V
2,27	IN 1	Audio signal input
3, 26	IN 2	The inversion signal of the operational amplifier inputs to IN 1 normally. The non-inversion signal of the operational amplifier inputs to IN 2 normally.
16	DI	Data input from the CPU. Schmitt inverter type
17	CLK	Clock signal input from the CPU. Schmitt inverter type
4~10 19~25	f1~f7	For connect to band-pass filter. f1~f7x2 (Left and Right)
11	TEST 1	Not use
12	TEST 2	Not use
13	S	Chip Select
28	NC	Not use

■ M5243P (IC552) : S.E.A. Graphic Equalizer

1. Functions  
It makes inductive characteristic instead of coil.
2. Block Diagram

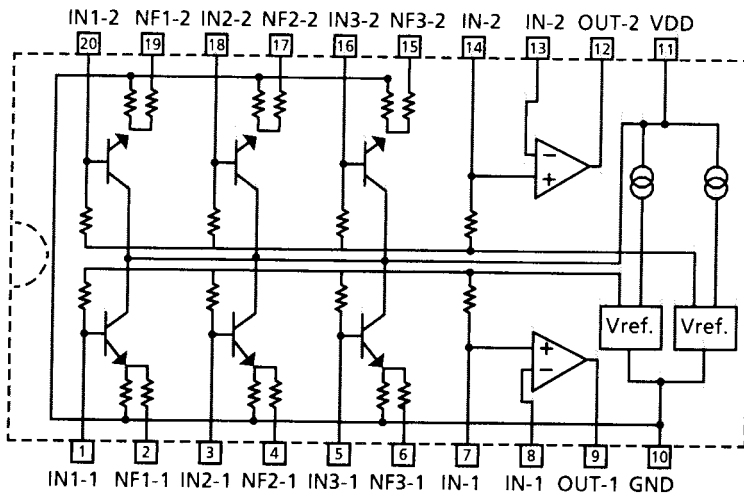

■ NJM2279D (IC221) : Video Switch

1. Terminal Layout

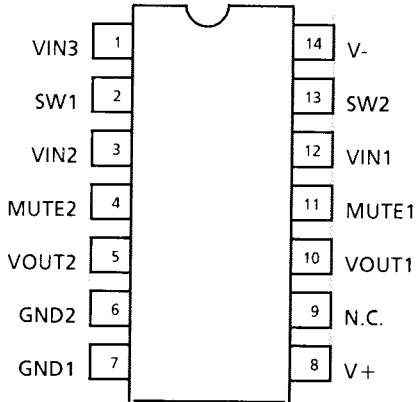

2. Block Diagram

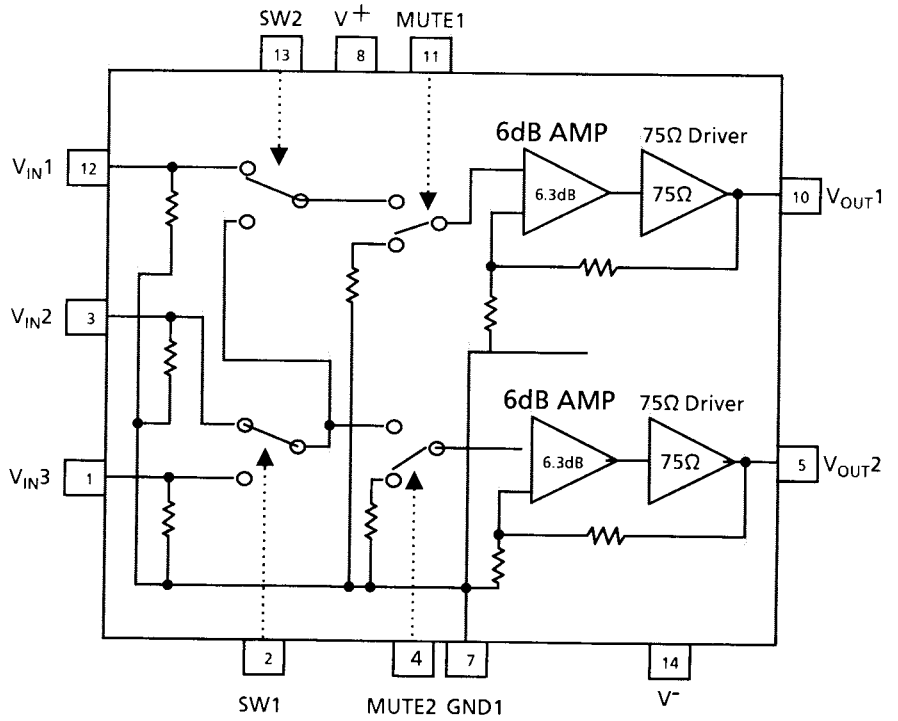

■ PST600E (IC403) : Reset IC

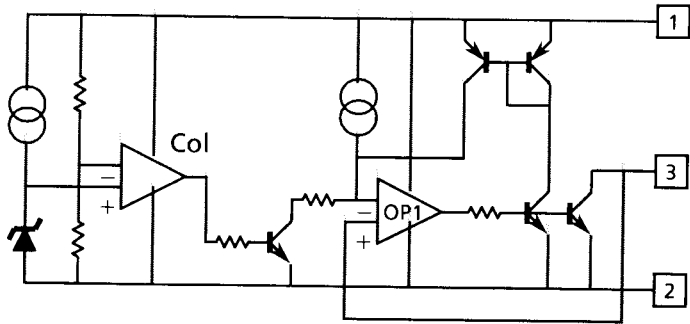

■ IC673 : M35012-120SP (ON SCREEN IC)

(1) Terminal Layout

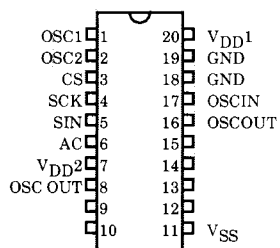

(2) Block Diagram

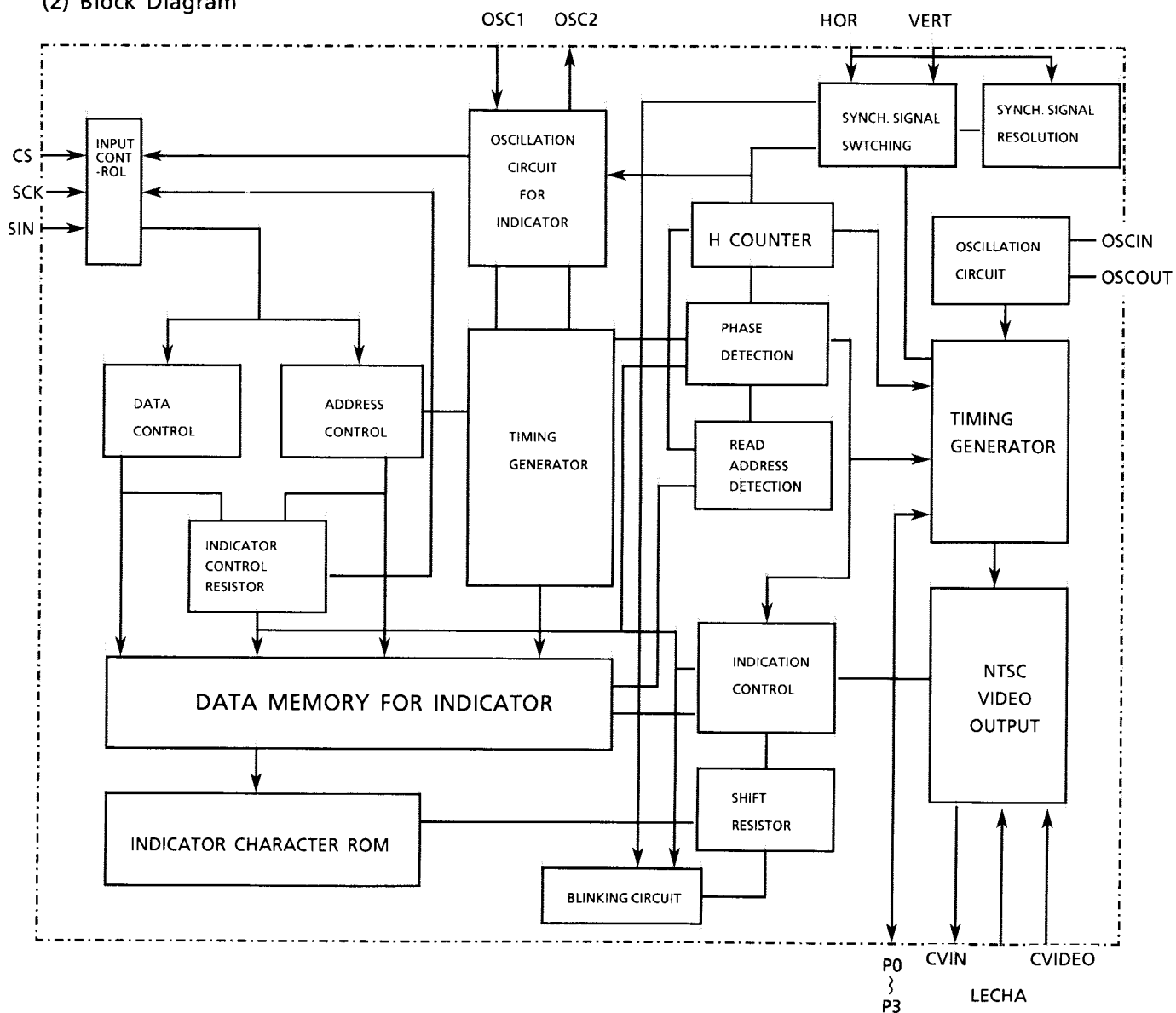

## (3) Pin Functions

Pin No.	Pin Name	Functions
1	OSC1	Oscillation terminal
2	OSC2	Oscillation terminal
3	CS	Chip Select
4	SCK	Serial clock signal
5	SIN	Serial data input
6	AC	Auto clear input
7	VDD2	Power supply
8	OSC OUT	Composite video signal input
9		NC
10		NC
11	VSS	GND
12		NC
13		NC
14		NC
15		NC
16	OSCOUT	Oscillation terminal
17	OSCIN	Oscillation terminal
18	GND	
19	GND	
20	VDD1	Power supply

■ TA7317P (IC901) : Protector

1. Terminal Layout

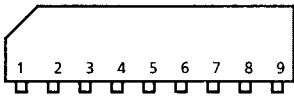

2. Block Diagram

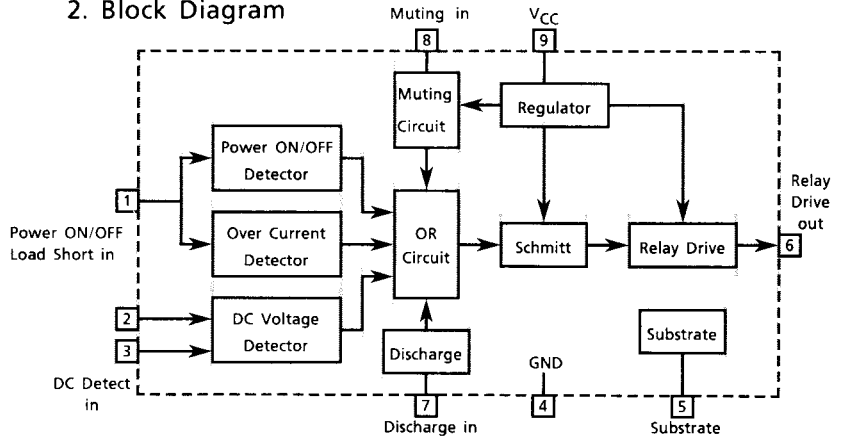

■ GP1U27X (IC402) : Receiver for remote controller

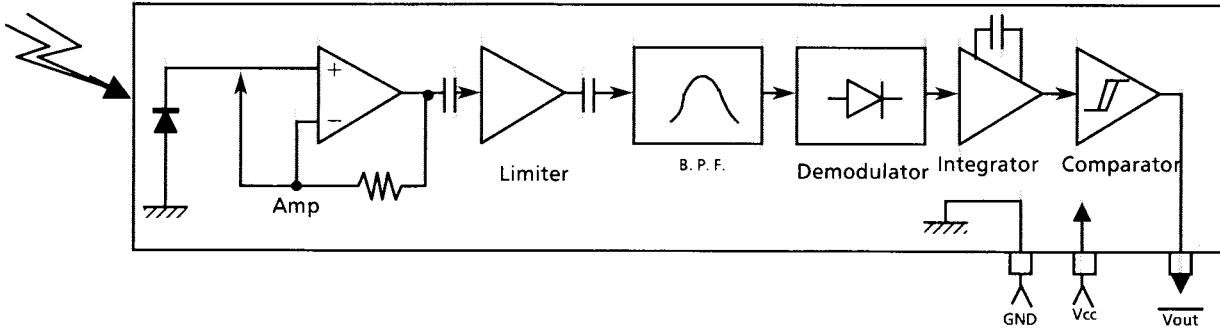

■ BU4051BC (IC501) : Analog Multiplexers / Demultiplexers

1. Terminal Layout

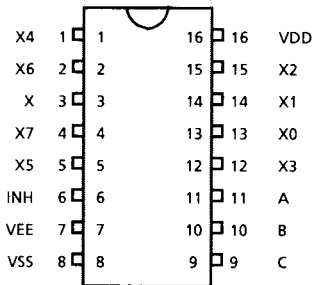

2. Block Diagram

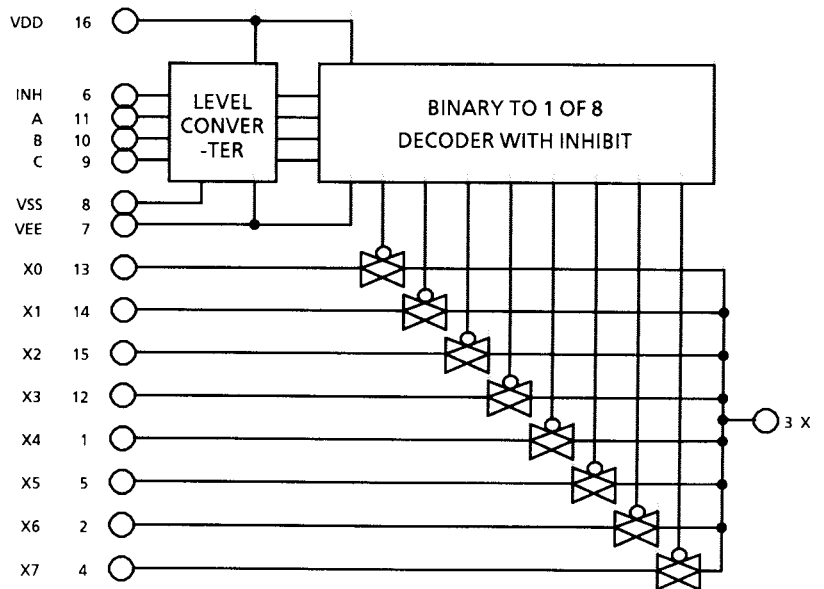

■ TC9274N - 007 (IC321) : Analog Switch Array

1. Terminal Layout

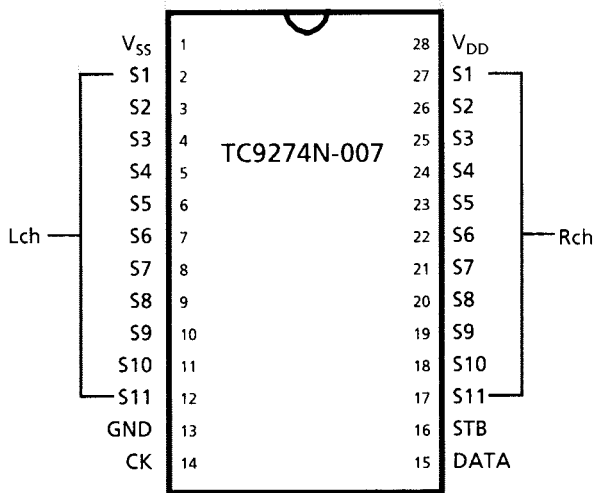

2. Block Diagram

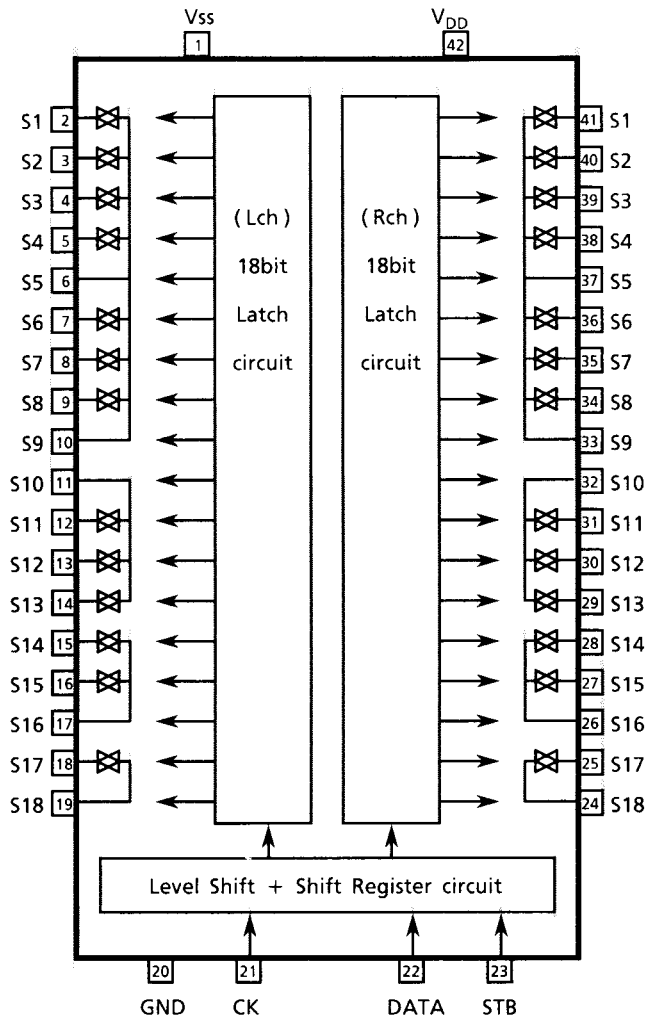

3. Pin Functions

Pin No.	Symbol	I/O	Functions and Operations
1	V <sub>SS</sub>	--	Power Supply .
2~19	S1~S18	I/O	Input / Output Terminal.
20	GND	--	Digital Ground.
21	CK	I	Clock Input Terminal.
22	DATA	I	Data Input Terminal.
23	STB	I	Strobe Input Terminal.
24~41	S18~S1	I/O	Input / Output Terminal.
42	V <sub>DD</sub>	--	Power Supply .

# Internal Connections of the FL Display

■ ELU0001-215 : DI400

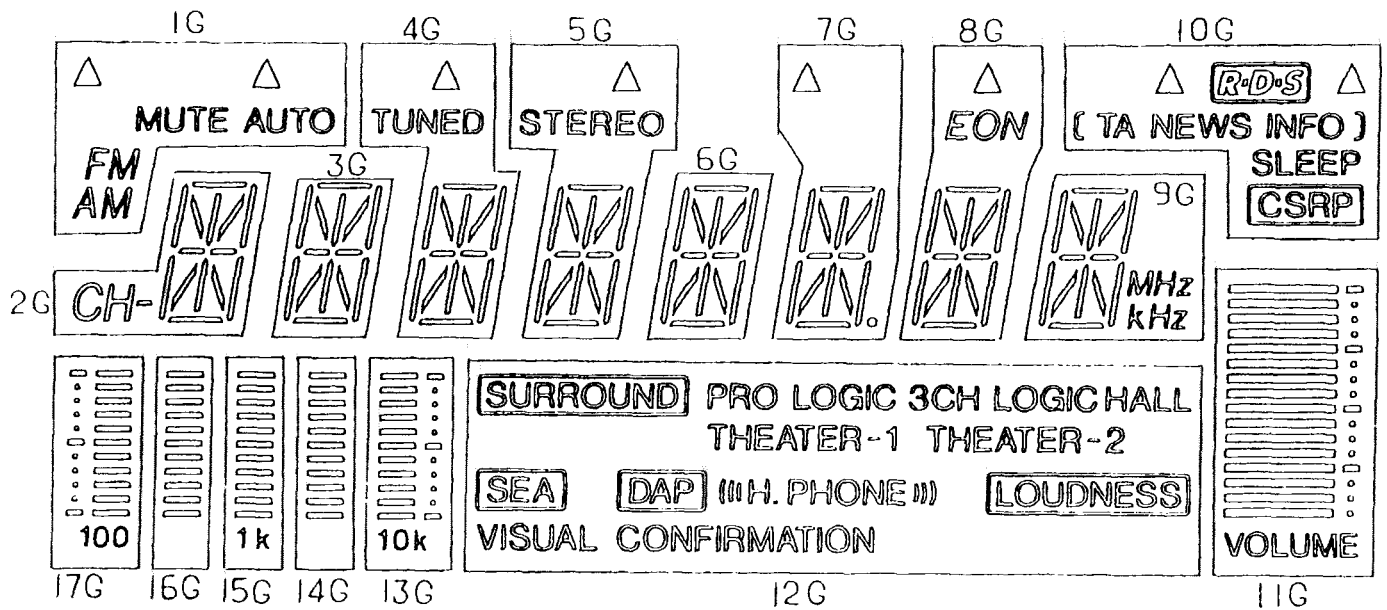

## Pin Connection

TERMINAL NO.	1	2	3	4	5	6	7	8	9	10	11	12	13	14						
ELECTRODE	F1	F1	F1	NP	17G	16G	15G	14G	13G	12G	11G	10G	9G	8G						
TERMINAL NO.	15	16	17	18	19	20	21	22	23	24	25	26	27	28	29	30	31	32	33	34
ELECTRODE	7G	6G	5G	4G	3G	2G	1G	NP	NP	NP	NP	NP	NP	P	P	P	P	P	P	P
TERMINAL NO.								35	36	37	38	39	40	41	42	43	44	45	46	47
ELECTRODE								P	P	P	P	P	P	P	P	P	NP	F2	F2	F2

Notes F: Filament NP: No Pin  
G: Grid  
P: Anode



# Internal Connection · Anode Designation

	1G	2G	3G	4G	5G	6G	7G	8G	9G	10G
S1		a	a	a	a	a	a	a	a	CSRP
S2		b	b	b	b	b	b	b	b	SLEEP
S3		i	i	i	i	i	i	i	i	TA
S4		j	j	j	j	j	j	j	j	NEWS
S5		h	h	h	h	h	h	h	h	INFO
S6		f	f	f	f	f	f	f	f	[ ]
S7		k	k	k	k	k	k	k	k	$\Delta$ (Right)
S8		g	g	g	g	g	g	g	g	R.D.S
S9		c	c	c	c	c	c	c	c	$\Delta$ (Left)
S10		l	l	l	l	l	l	l	l	
S11	FM	n	n	n	n	n	n	n	n	
S12	AM	m	m	m	m	m	m	m	m	
S13	MUTE AUTO	e	e	e	e	e	e	e	e	
S14		d	d	d	d	d	d	d	d	
S15	$\Delta$ (Left)	CH-		TUNED	STEREO		<sup>(Dot)</sup> EON		MHz	
S16	$\Delta$ (Right)			$\Delta$	$\Delta$		$\Delta$	$\Delta$	KHz	

	11G	12G	13G	14G	15G	16G	17G
S1	A1						
S2	A2	LOUDNESS					Scale (Left)
S3	A3	VISUAL CON- FIRMATION	10k		1k		100
S4	A4						
S5	A5		B1	B1	B1	B1	B1
S6	A6		B2	B2	B2	B2	B2
S7	A7		B3	B3	B3	B3	B3
S8	A8	THEATER-2	B4	B4	B4	B4	B4
S9	A9	HALL	B5	B5	B5	B5	B5
S10	A10	3CH LOGIC	B6	B6	B6	B6	B6
S11	A11	H. PHONE	B7	B7	B7	B7	B7
S12	A12	THEATER-1	B8	B8	B8	B8	B8
S13	A13	PRO LOGIC	B9	B9	B9	B9	B9
S14	A14	DAP	B10	B10	B10	B10	B10
S15	A15	SEA	B11	B11	B11	B11	B11
S16	A16	SURROUND	Scale (Right)				

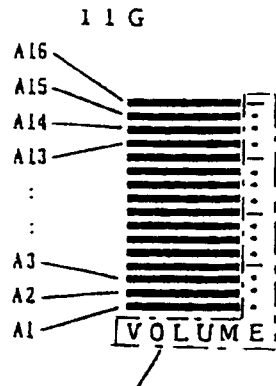
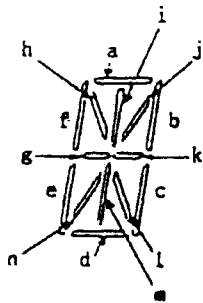

·These segments pattern  
are connected to 11G.

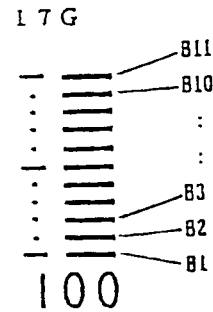

·The segment pattern of  
13G to 16G is same as above.

# Disassembly Procedures

(1) Removing the top cover

1. Remove 4 screws (A) fastening both sides of top cover, and 3 screws (B) fastening the rear side.
2. Remove the top cover.

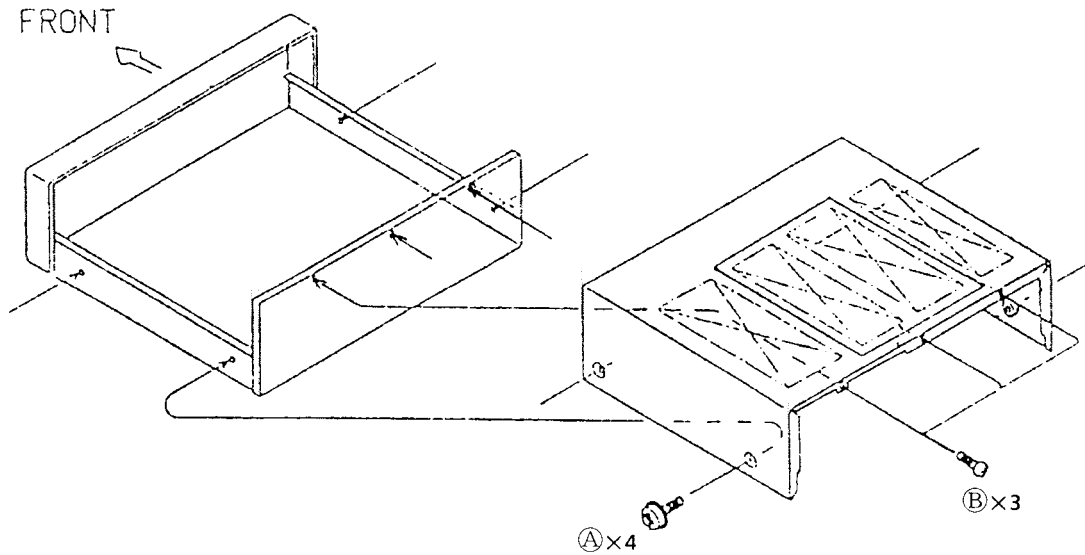

(2) Removing the Bottom Cover

1. Remove 14 screws (C) and (C").
2. Remove the bottom cover.

※ The screw (C") which secures the bottom cover is also used for ground.  
It is necessary to ground before checking after the bottom cover is removed.

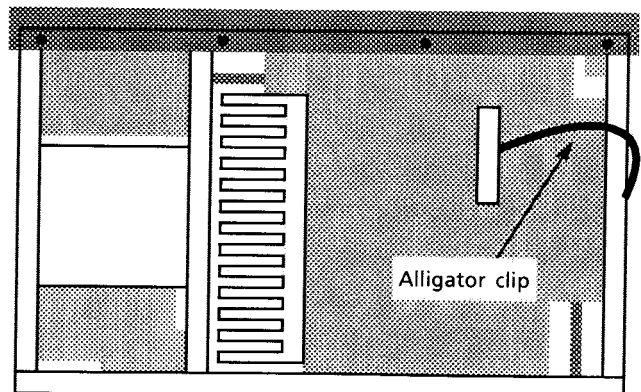
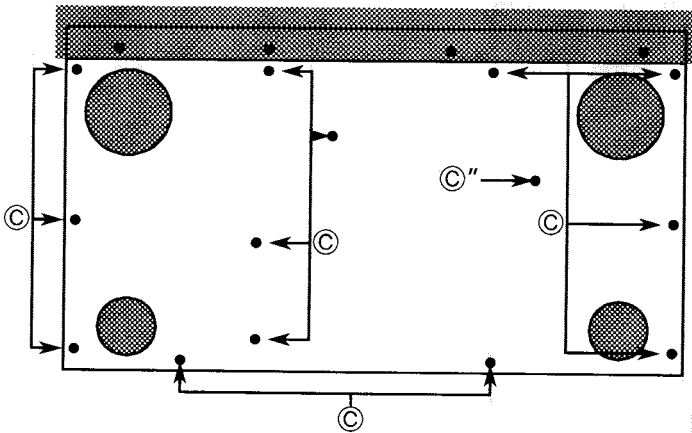

(A) .. E61660-004

(B) ... E73273-003

(C),(C") .... SBSG3008CC

**(3) Removing the Front Panel Assembly**

1. Removing the top cover.
2. Remove 3 screws  $\textcircled{C}$  fastening top of the front panel, and 4 screws  $\textcircled{D}$  fastening bottom of it.
3. Remove the front panel disconnecting some wires. (CN411,CN413,CN415)

**(4) Removing the Front P.C. Board**

1. Removing the top cover.
2. Removing the front panel assembly.
3. Remove 9 screws  $\textcircled{E}$ .
4. Remove the Master volume knob.
5. Remove a nut fastening the Master volume.
6. Remove the front P.C. Board.

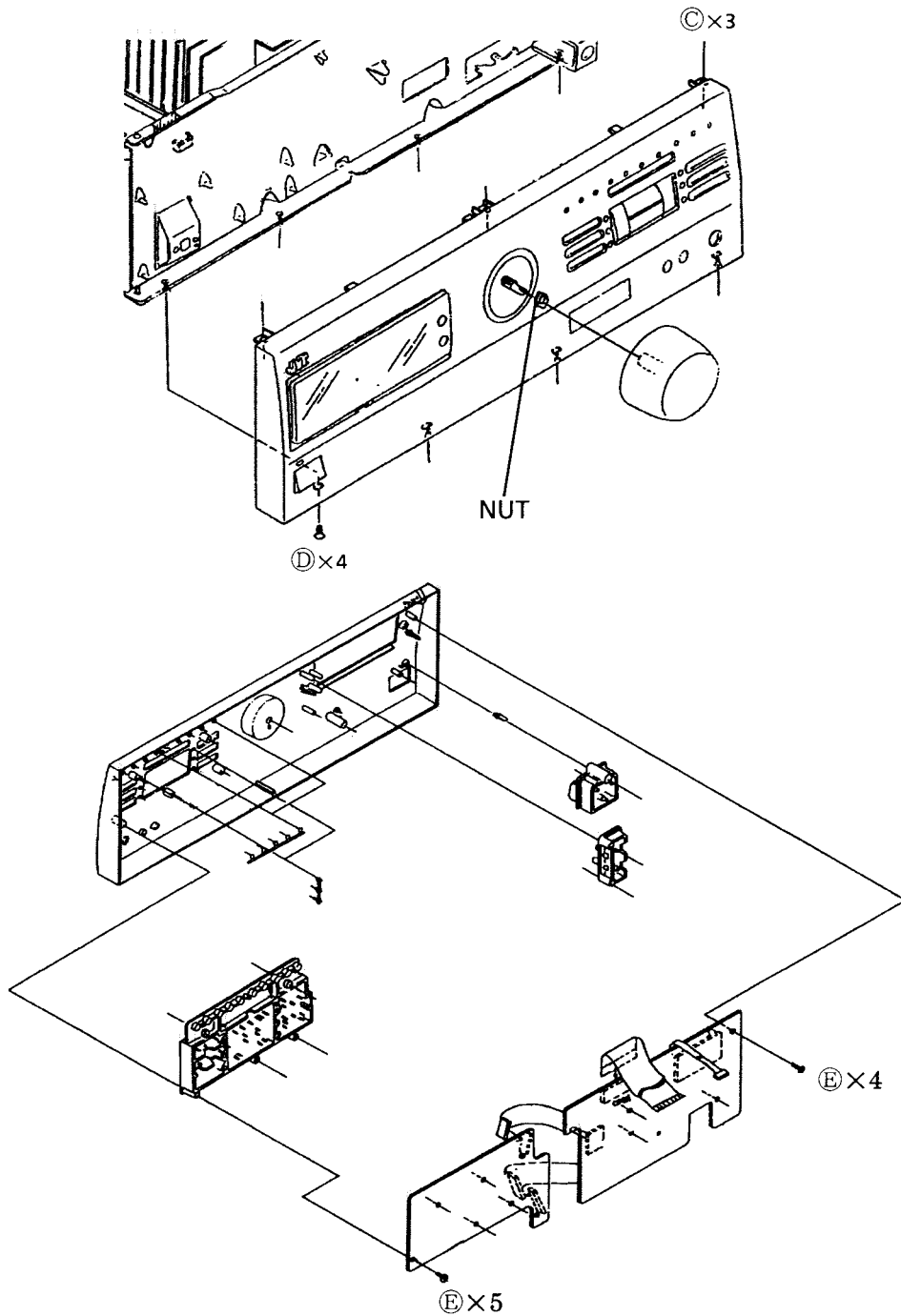
 $\textcircled{C}$  .. SBSG3008CC $\textcircled{D}$  ... SD SG3008M $\textcircled{E}$  ... SDSF2608Z

## (5) Removing the Rear Panel

1. Removing the top cover.
2. Remove 19 screws (B), (B").
3. Remove 2 screws (C) fastening bottom sides of rear panel.
4. Take it out.

※ 8pcs. of screw (B)" which secure the rear panel are also used for ground.  
Installing of those screws is required before checking.

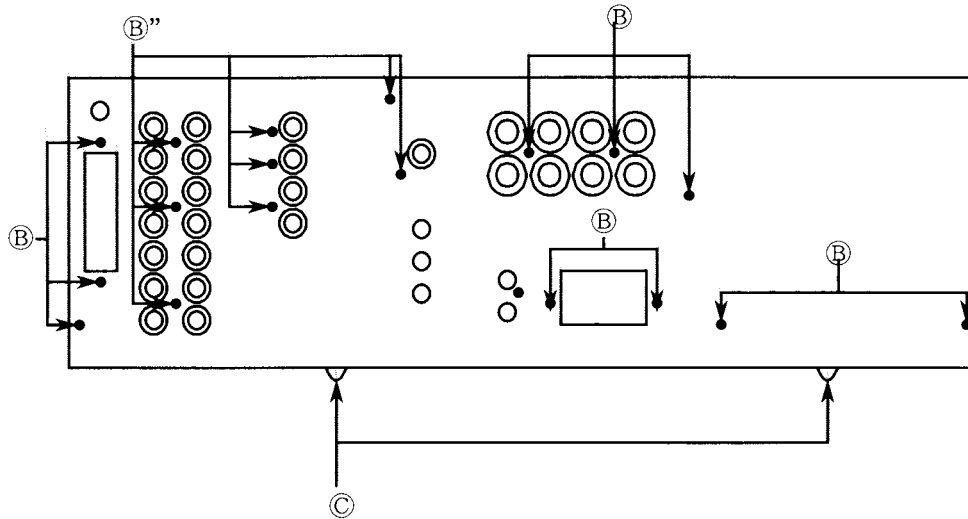

(B), (B)" .... E73273-003

(C) .... SBSG3008CC

**(6) Removing the Power Transistor**

1. Remove the rear panel and bottom cover.
2. Remove screw © fastening SURROUND PCB (ENC-138-6).
3. Disconnect CN001 to disassemble the tuner PCB (ENA-178).
4. Disconnect CN601 and CN602 to disassemble the audio PCB (ENC-138-1) and SURROUND PCB. (Remove each wires if necessary.)
5. Disconnect CN501 to disassemble the video PCB (ENC-138-2). (Remove each wires if necessary.)
6. Disconnect CN701 to disassemble the subwoofer PCB (ENB-252-3). (Remove each wires if necessary.)

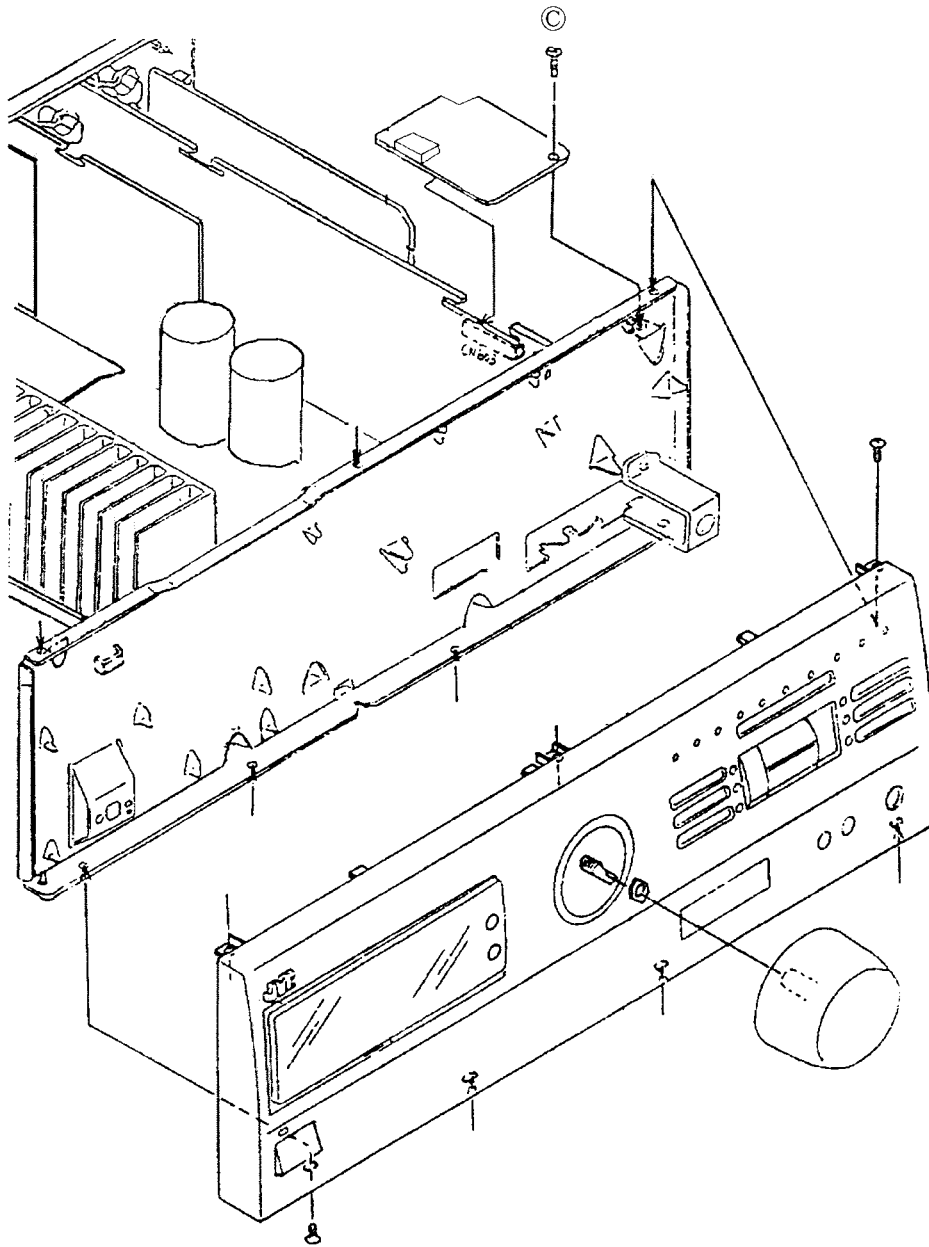

8. Unsolder the broken transistor.
9. Remove the some screws  $\text{\textcircled{F}}$  fastening it.
10. Remove it.

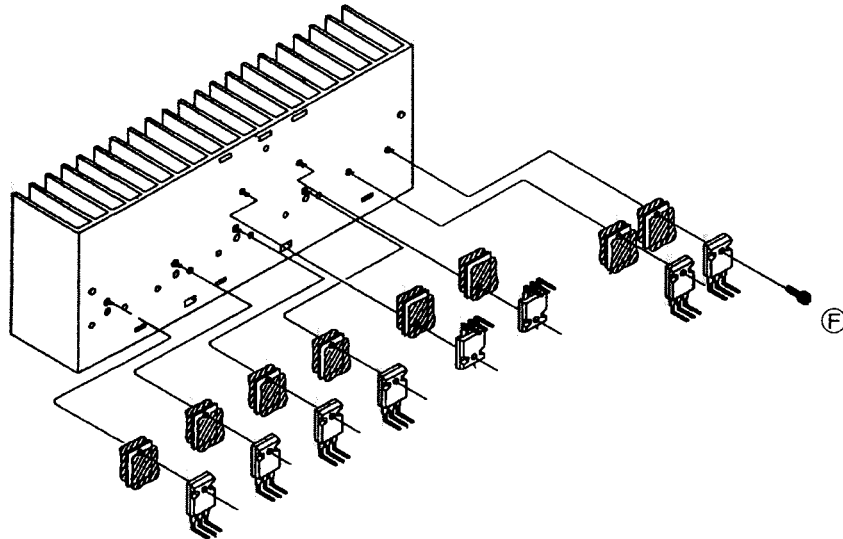

$\text{\textcircled{F}}$  ..... E73525-003

# ADJUSTMENT PROCEDURES

## ■ Tuner section

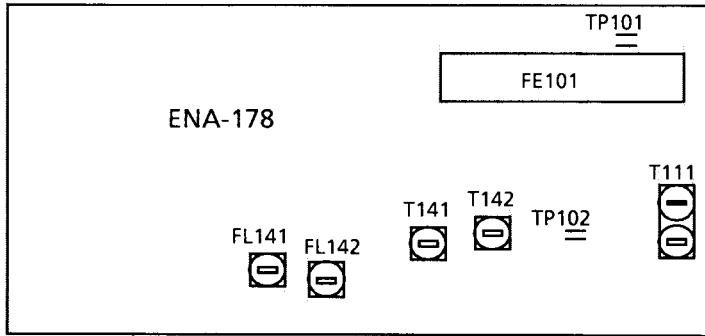

Tuning range

Area	Range	
	MW (kHz)	FM (MHz)
the U.S.A., Canada	530~1710	87.5MHz~108MHz

### (1) Tuning Voltage

Confirm the voltages in the table at TP101.

FM Tuning voltage (Unit : V)

Area	Frequency	
	87.5MHz	108MHz
the U.S.A., Canada,	$1.6 \pm 1.0$	$8.0 \pm 2.0$

AM Tuning voltage (Unit : V)

Area	Frequency (MW)	
	530KHz	1710KHz
the U.S.A., Canada	$1.0 > 0.5$	$8.0 \pm 0.8$

### (2) FM Center meter

Receive a broadcast by using the function of 'AUTO STOP'.

Adjust T105 (Detector coil) so taht the voltage at TP102 becomes  $0 \pm 1.5mV$ .

## ■ Power Amplifier section

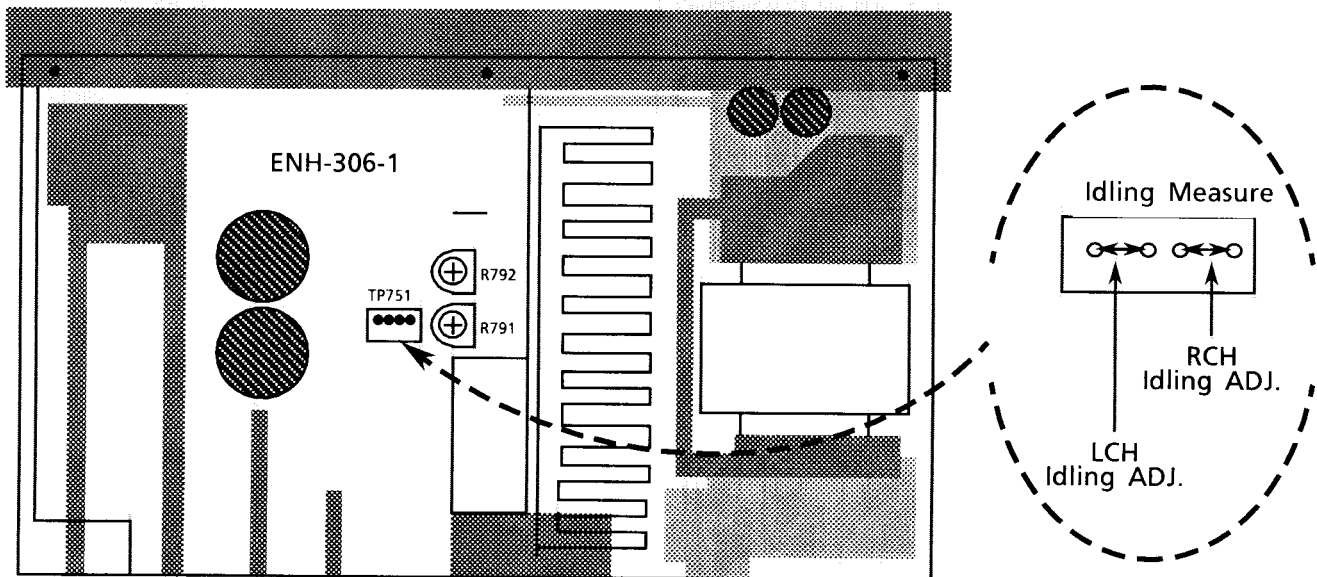

## ■ Idling current

- (1) Set the volume control to minimum during this adjustment. Set surround mode "OFF". And set speaker load selector "HIGH".
- (2) Turn R791 and R792 fully counterclockwies to warm up befor adjustment.  
If the heatsink is already warm from previous use the correct adjustment can not be made.
- (3) Connect a DC voltmeter to TP751.
- (4) Adjust TP751, so that the DC voltmeter becomes  $1mV \sim 10mV$ .

# Block Diagrams

## Signal Flow

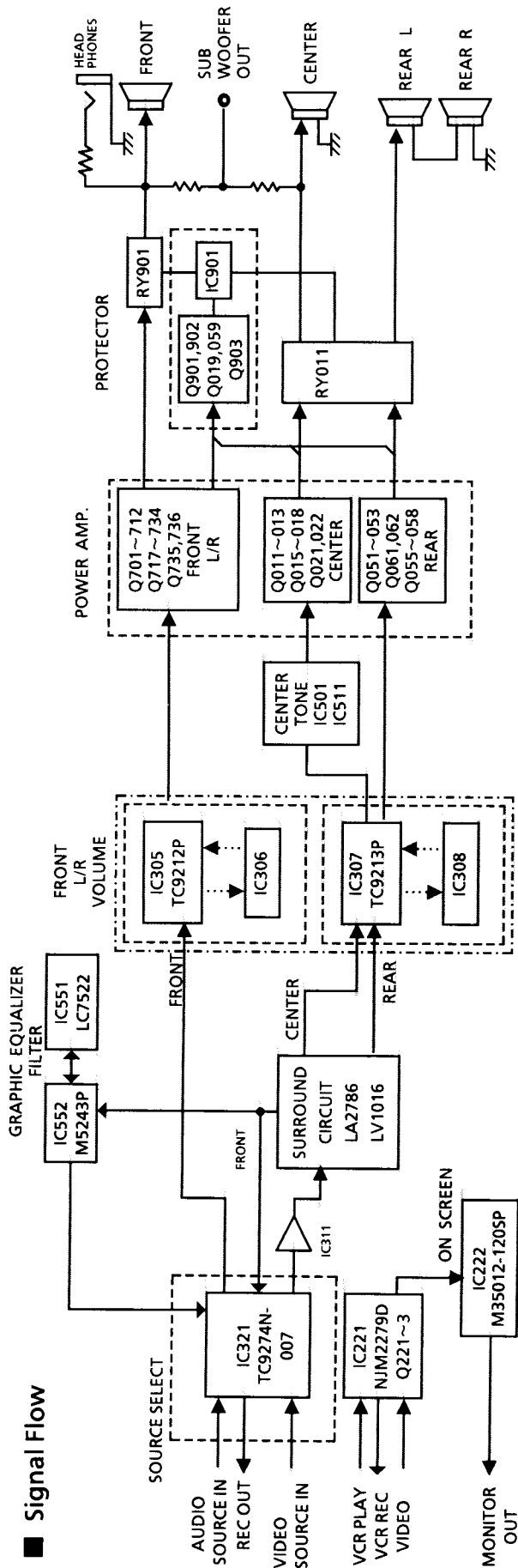

## Control Section

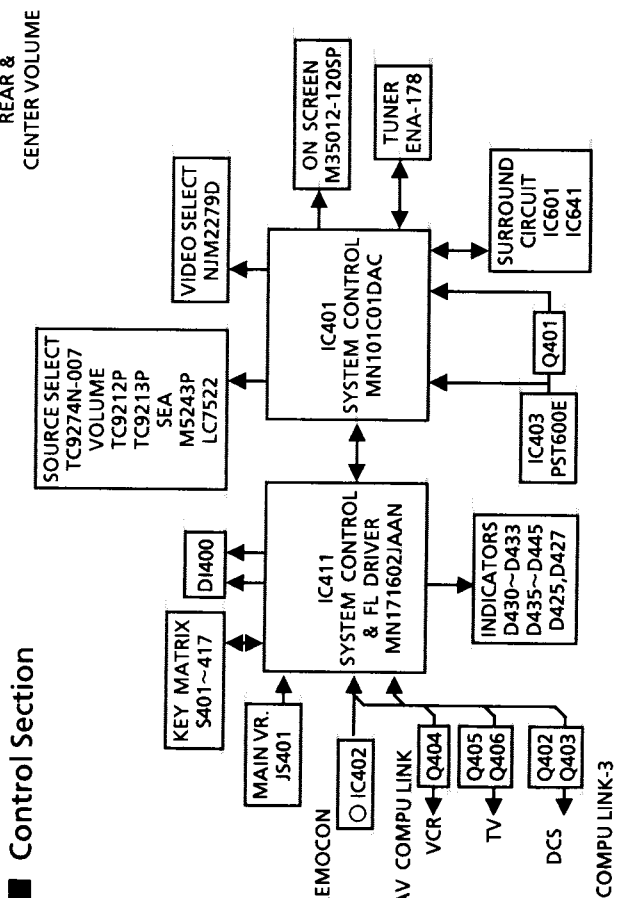

## Power Supply Section

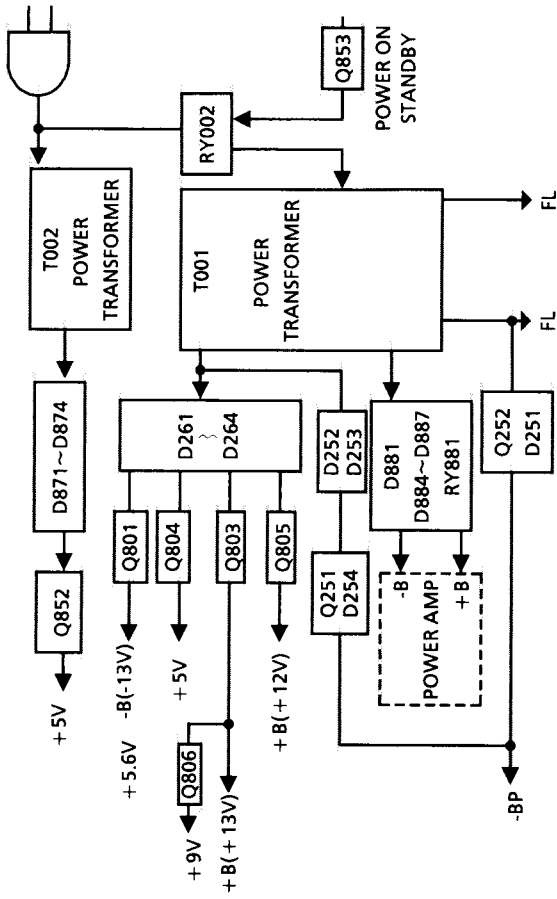



■ Tuner Section

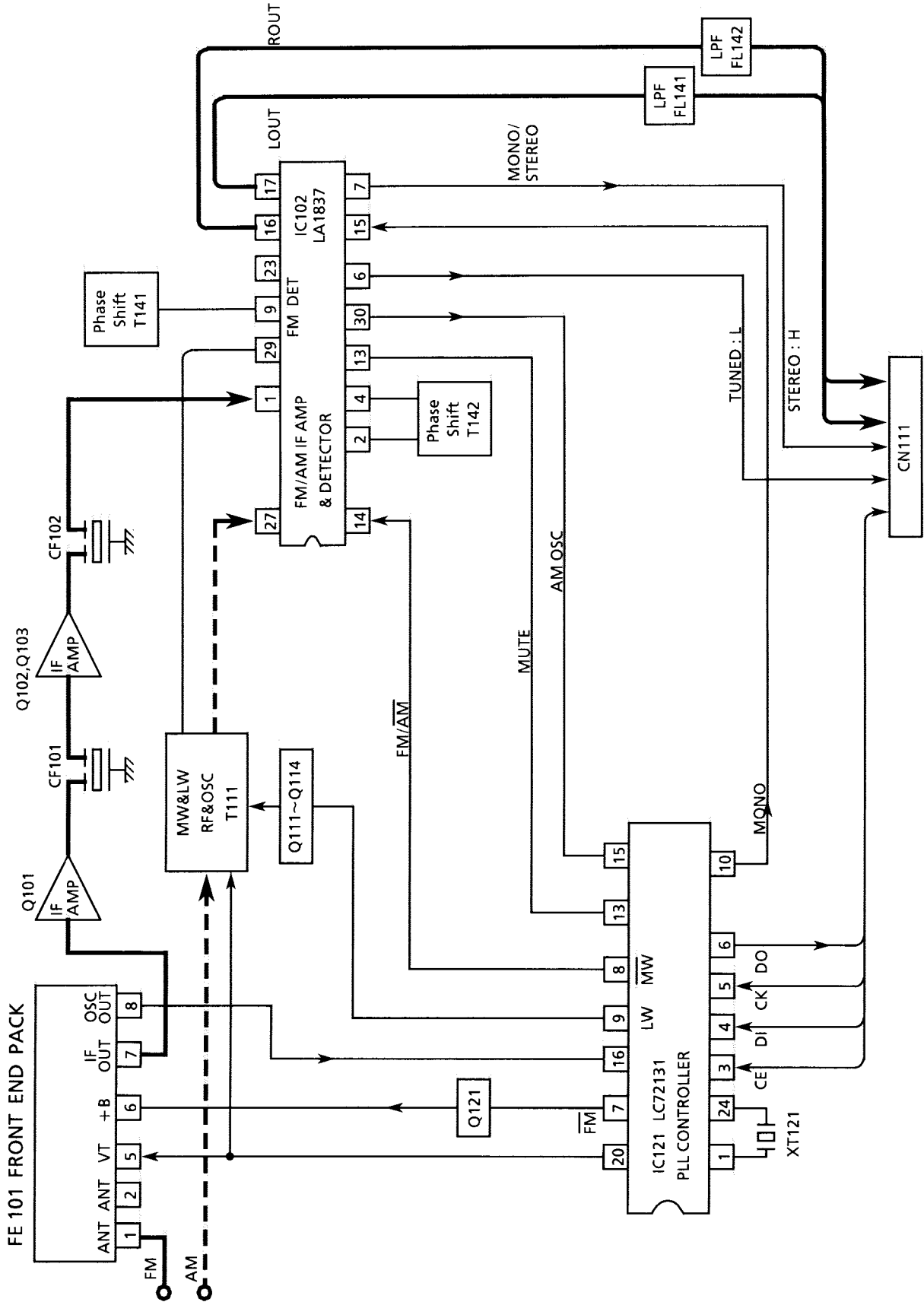

— MEMO —



# Printed Circuit Boards

## MAIN AMP. P.C.BORD(ENH-306)

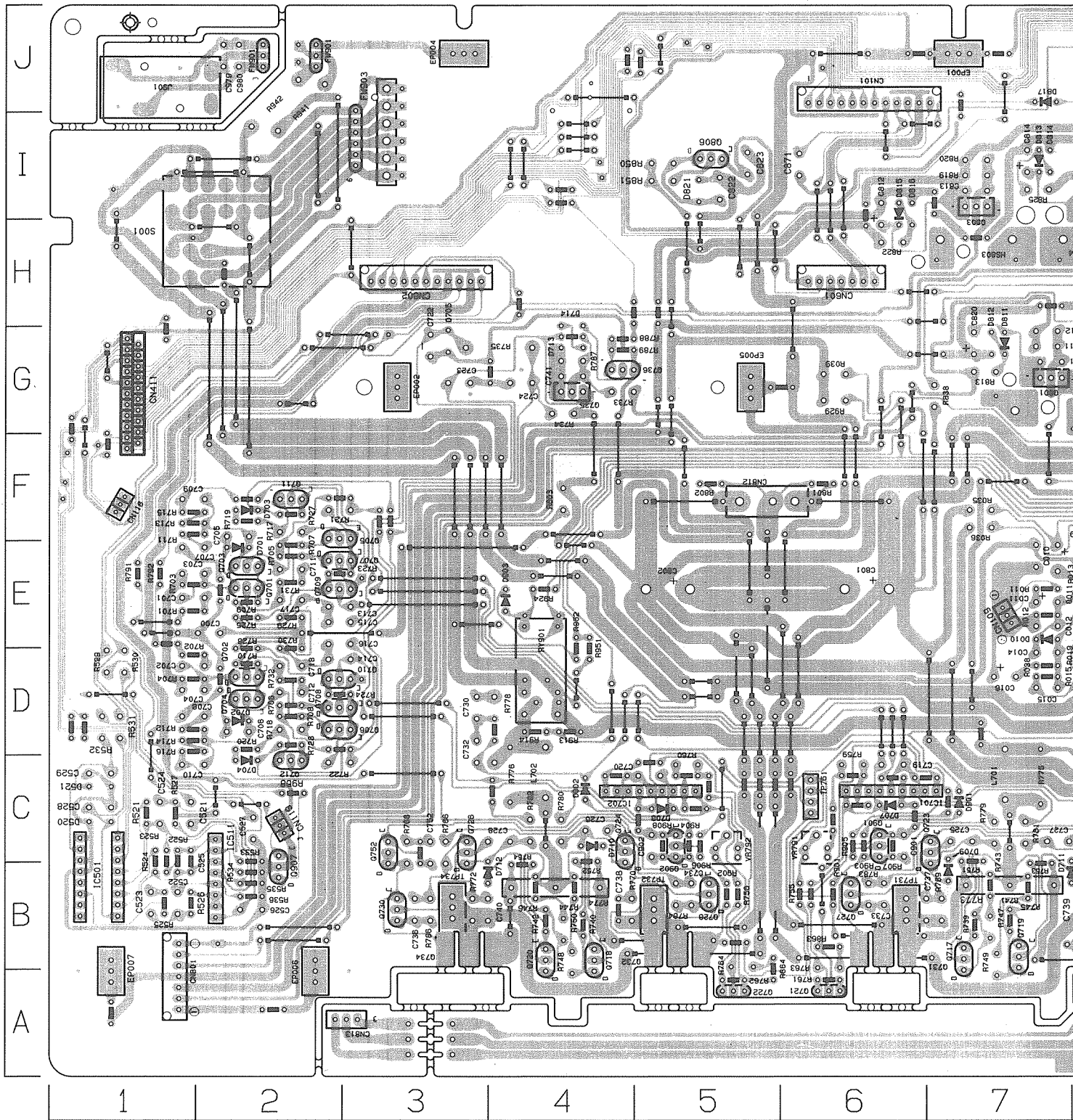

Location List (ENH-306)

Symbol	X	Y	Symbol	X	Y	Symbol	X	Y	Symbol	X	Y	Symbol	X	Y	Symbol	X	Y			
C010	7	E	C730	3	D	D016	8	D	Q705	2	F	R046	9	B	R751	7	C	R909	9	E
C011	7	E	C731	8	D	D021	9	C	Q706	2	D	R047	9	C	R752	4	C	R911	9	E
C012	7	E	C732	3	D	D022	9	C	Q707	2	E	R048	9	C	R753	7	B	R912	9	E
C013	8	E	C733	6	B	D482	10	E	Q708	2	D	R073	9	H	R754	4	B	R913	4	D
C014	7	D	C734	5	B	D483	10	D	Q709	2	E	R074	9	E	R755	6	B	R914	4	D
C015	7	D	C735	5	B	D484	10	D	Q710	2	D	R081	10	C	R756	5	B	R915	9	E
C016	7	D	C736	3	B	D520	1	C	Q711	2	F	R091	10	B	R759	6	C	R916	8	E
C017	7	D	C737	6	B	D921	1	C	Q712	2	C	R092	10	C	R760	5	C	R917	8	E
C018	8	D	C738	4	B	D701	2	E	Q717	7	A	R481	10	E	R761	6	A	R918	8	E
C019	8	D	C739	8	B	D702	2	D	Q718	4	A	R482	10	D	R762	5	A	R921	9	F
C020	8	D	C740	3	B	D703	2	F	Q719	7	B	R521	1	C	R763	6	B	R922	9	F
C021	8	D	C741	4	G	D704	2	C	Q720	4	A	R522	1	B	R764	5	B	R924	4	E
C022	8	D	C751	3	C	D705	3	C	Q721	6	A	R523	1	C	R765	8	C	R929	6	G
C023	8	D	C752	3	C	D707	6	C	Q722	5	A	R524	1	C	R766	3	C	R941	2	J
C024	8	D	C801	6	E	D708	5	C	Q723	7	B	R525	1	B	R767	8	C	R942	2	J
C025	9	D	C802	5	E	D709	7	B	Q724	4	B	R526	1	B	R768	3	C	R951	4	E
C026	9	D	C812	9	H	D710	4	C	Q725	8	B	R527	1	C	R769	7	B	R952	4	E
C027	9	D	C813	9	H	D711	7	B	Q726	3	B	R529	1	D	R770	4	B	R953	10	E
C028	10	C	C814	7	I	D712	3	B	Q727	6	B	R530	1	D	R771	8	B	R961	9	I
C029	9	D	C818	8	I	D713	4	G	Q728	5	B	R531	1	D	R772	3	B	R962	10	G
C030	9	D	C817	6	I	D714	4	H	Q729	8	B	R532	1	D	R773	7	B	R963	9	J
C031	10	C	C819	8	G	D811	7	G	Q730	3	B	R533	2	C	R774	4	B	R964	10	H
C032	10	C	C820	7	G	D812	7	G	Q731	6	B	R534	2	B	R775	7	D	R965	9	F
C033	10	C	C821	7	G	D813	7	I	Q732	5	B	R535	2	B	R776	4	D	R966	10	F
C034	10	C	C822	5	I	D814	7	I	Q733	8	B	R536	2	B	R777	8	B	R967	10	F
C035	10	C	C823	5	I	D815	6	I	Q734	3	B	R701	2	E	R778	4	D	R968	2	C
C036	10	C	C824	8	I	D816	6	I	Q735	4	G	R702	2	D	R779	7	F	R969	8	F
C037	10	C	C825	8	I	D817	7	J	Q736	4	G	R703	2	E	R780	4	C	R970	9	F
C038	10	C	C901	6	C	D818	8	I	Q751	8	B	R704	2	D	R781	7	C	R971	9	E
C039	10	C	C902	5	C	D819	8	I	Q752	3	B	R705	2	E	R782	4	C	R972	4	E
C040	10	C	C903	9	E	D820	8	H	Q801	7	G	R706	2	D	R783	6	B	R973	4	E
C041	10	C	C904	6	E	D821	5	I	Q803	7	I	R707	2	E	R784	5	B	R974	1	I
C042	10	C	C905	5	E	D901	7	C	Q804	1	I	R708	2	D	R785	8	B	R975	1	I
C043	10	C	C906	3	E	D902	4	C	Q805	9	I	R709	2	E	R786	3	B	R976	1	I
C044	10	C	C909	9	E	D903	4	E	Q806	5	I	R710	2	D	R787	4	G	R977	1	I
C045	10	C	C965	10	H	FW901A	2	J	Q901	6	C	R711	2	F	R788	4	G	R978	1	I
C046	10	C	C966	10	H	FW901B	2	J	Q902	5	C	R712	2	F	R789	4	G	R979	1	I
C047	10	C	C967	10	H	FW903	3	J	Q903	9	D	R713	2	F	R791	1	E	R980	1	I
C048	10	C	C968	10	H	FW903A	9	I	Q904	10	F	R714	2	D	R792	1	E	R981	1	I
C049	10	C	C969	10	H	FW903C	9	I	Q905	8	F	R715	2	F	R793	1	E	R982	1	I
C050	10	C	C970	10	H	FW903D	3	J	Q906	9	F	R716	2	D	R794	1	E	R983	1	I
C051	10	C	C971	10	H	IC501	1	B	Q907	2	B	R717	2	F	R795	1	E	R984	1	I
C052	10	C	C972	10	H	IC511	2	C	R011	7	E	R718	2	D	R796	1	E	R985	1	I
C053	10	C	C973	10	H	IC701	6	C	R012	7	E	R719	2	F	R797	1	E	R986	1	I
C054	10	C	C974	10	H	IC702	5	C	R013	8	E	R720	2	D	R798	1	E	R987	1	I
C055	10	C	C975	10	H	IC901	8	E	R014	8	E	R721	3	F	R799	1	E	R988	1	I
C056	10	C	C976	10	H	J481	10	D	R015	7	D	R722	3	C	R801	6	F	R989	1	I
C057	10	C	C977	10	H	J901	1	J	R016	8	E	R723	3	E	R802	5	F	R990	1	I
C058	10	C	C978	10	H	L011	8	D	R017	8	E	R724	3	D	R803	4	G	R991	1	I
C059	10	C	C979	2	J	L012	10	D	R018	8	D	R725	2	E	R804	7	F	R992	1	I
C060	10	C	C980	2	J	L052	10	D	R019	8	D	R726	2	D	R805	8	G	R993	1	I
C061	10	C	CN101	7	F	L701	7	D	R020	8	E	R727	2	F	R806	7	F	R994	1	I
C062	10	C	CN108	10	F	L702	4	D	R023	9	B	R728	2	D	R807	9	I	R995	1	I
C063	10	C	CN109	7	E	L561	10	I	R024	10	C	R729	2	E	R808	8	G	R996	1	I
C064	10	C	CN118	1	F	L562	9	I	R025	8	C	R730	2	D	R809	8	G	R997	1	I
C065	10	C	CN119	2	C	L563	10	H	R026	9	C	R731	2	E	R810	9	I	R998	1	I
C066	10	C	CN311	8	G	L564	9	H	R027	9	B	R732	2	D	R811	7	F	R999	1	I
C067	10	C	CN411	1	F	IC100	11	D	R028	8	D	R733	4	G	R812	7	F	R1000	1	I
C068	10	C	CN501	1	F	L2102	1	C	R029	9	F	R734	4	G	R813	7	F	R1001	1	I
C069	10	C	CN601	9	H	IC013	8	D	R030	10	D	R735	4	G	R814	8	J	R1002	1	I
C070	10	C	CN602	9	H	IC015	9	C	R031	9	D	R736	4	G	R815	8	J	R1003	1	I
C071	10	C	CN701	10	E	IC019	9	B	R032	9	C	R737	4	G	R816	8	J	R1004	1	I
C072	10	C	CN801	10	E	IC017	8	B	R033	10	D	R738	4	G	R817	8	J	R1005	1	I
C073	10	C	CN812	5	F	IC018	9	B	R034	9	E	R739	4	G	R818	8	J	R1006	1	I
C074	10	C	CN813	2	A	IC019	9	C	R035	7	F	R740	4	B	R819	8	J	R1007	1	I
C075	10	C	CN814	8	A	IC020	9	D	R036	7	F	R741	4	B	R820	8	J	R1008	1	I
C076	10	C	D010	7	E	IC021	9	C	R037	8	E	R742	4	B	R821	8	J	R1009	1	I
C077	10	C	D011	8	E	IC022	9	C	R038	7	D	R743	4	B	R822	8	J	R1010	1	I
C078	10	C	D012	9	D	IC023	9	C	R039	6	G	R744	4	B	R823	8	J	R1011	1	I
C079	10	C	D013	8	E	IC024	9	C	R040	9	E	R745	4	B	R824	8	J	R1012	1	I
C080	10	C	D014	3	E	IC025	9	C	R041	8	E	R746	4	B	R825	8	J	R1013	1	I
C081	10	C	D015	8	D	IC026	2	D	R042	8	E	R747	4	B	R826	8	J	R1014	1	I
C082	10	C	D016	8	D	IC027	2	D	R043	10	C	R748	4	B	R827	8	J	R1015	1	I
C083	10	C	D017	8	D	IC028	2	D	R044	9	B	R749	4	B	R828	8	J	R1016	1	I
C084	10	C	D018	8	D	IC029	2	D	R045	9	B	R750	4	B	R829	8	J	R1017	1	I

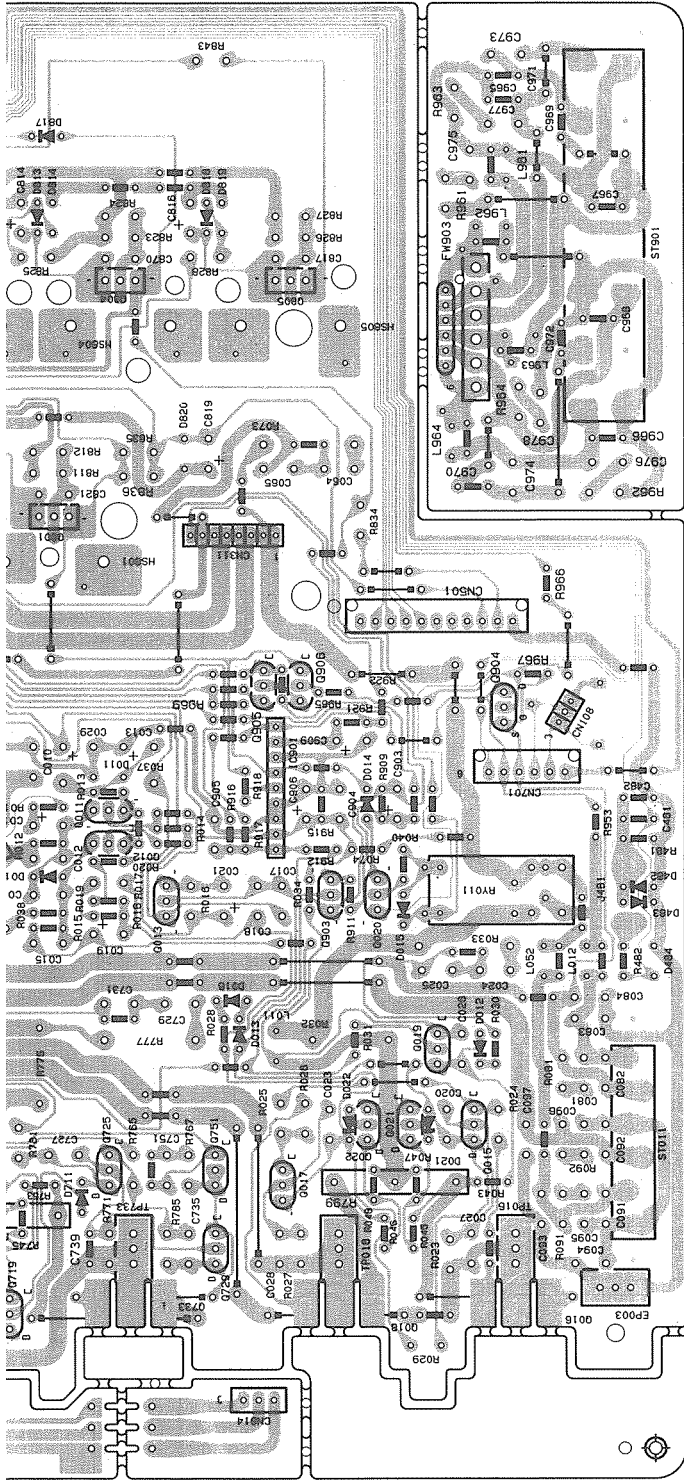

8 9 10

INPUT P.C. BOARD (ENC-138)

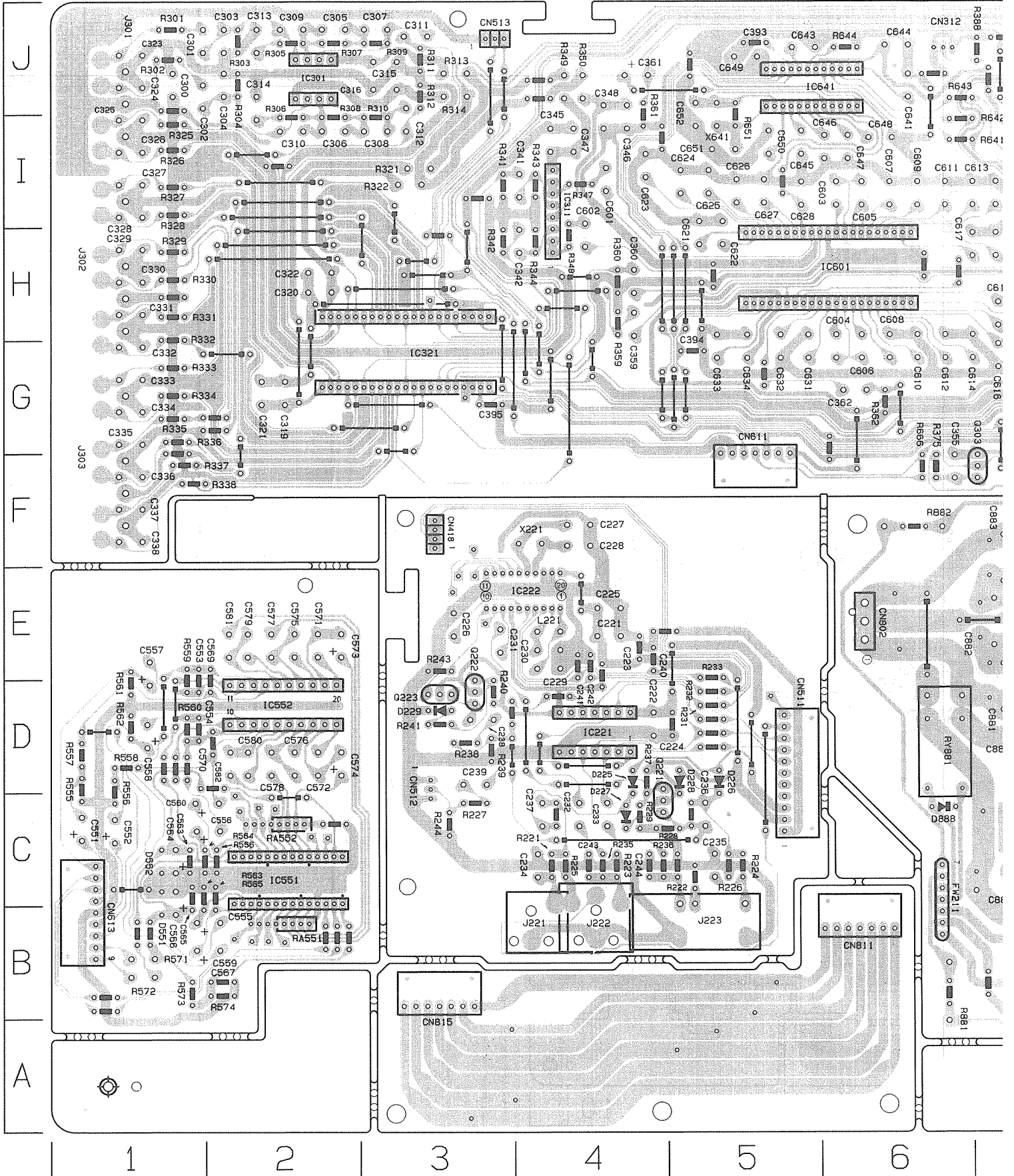

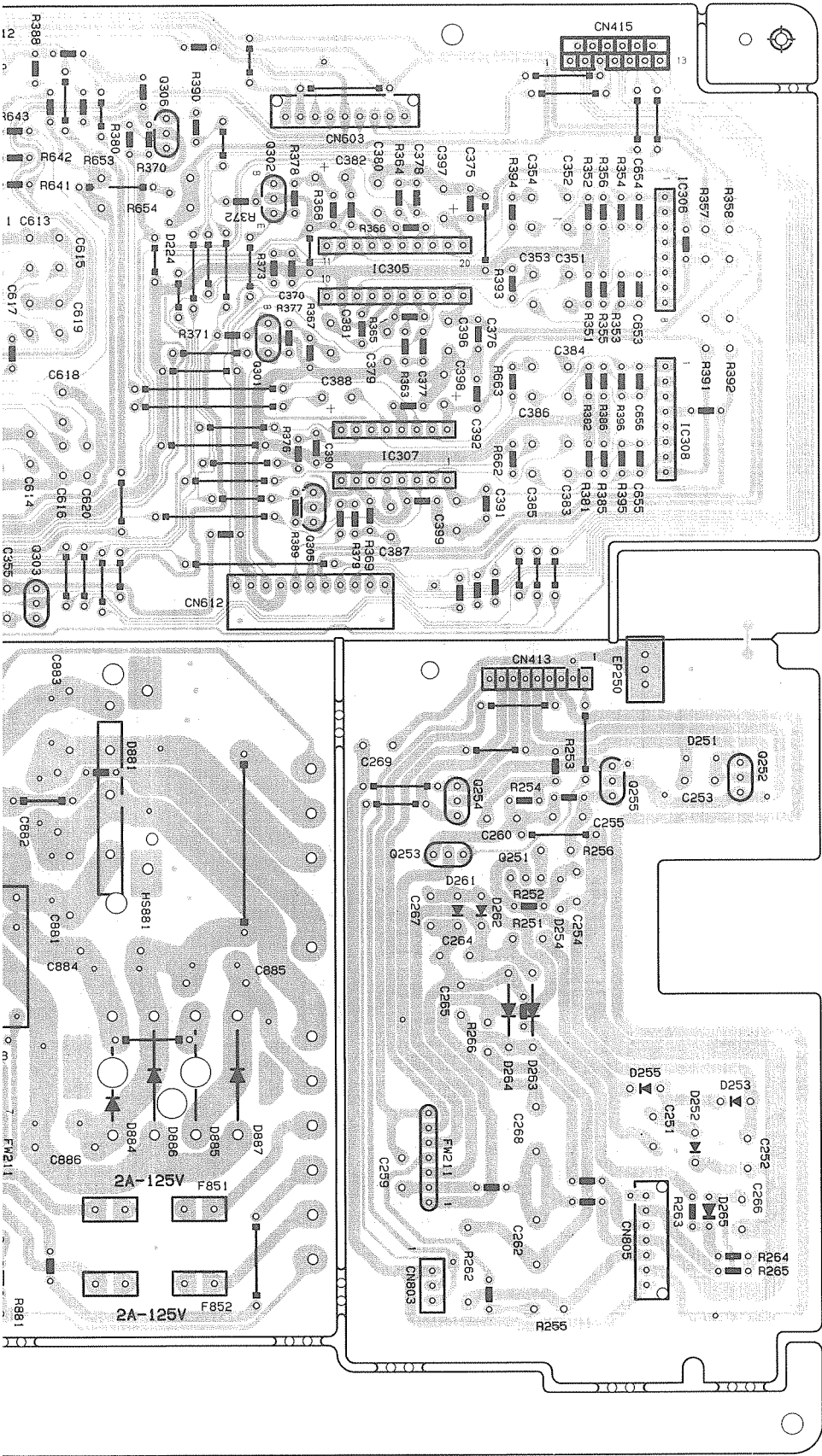

Location List (ENC-138)

Symbol	X	Y	Symbol	X	Y	Symbol	X	Y	Symbol	X	Y	Symbol	X	Y	Symbol	X	Y
C0881	7	D	C030	1	H	C577	2	E	CN005	10	B	R229	4	C	R361	4	I
C0882	7	E	C031	1	H	C578	2	D	CN011	6	B	R231	5	D	R362	6	G
C0883	7	F	C032	1	G	C579	2	E	CN015	3	B	R232	5	D	R363	5	H
C0884	7	D	C033	1	G	C580	2	D	D224	7	I	R233	5	E	R364	5	I
C0885	8	D	C034	1	G	C581	2	E	D225	4	D	R235	4	C	R365	5	H
C0886	7	C	C035	1	G	C582	2	D	D226	5	D	R236	4	C	R366	9	I
C221	4	E	C036	1	F	C601	4	I	D227	4	C	R237	4	D	R367	8	H
C222	4	D	C037	1	F	C602	4	H	D228	5	D	R238	3	D	R368	8	I
C223	4	E	C038	1	F	C603	6	I	D229	3	D	R239	3	D	R369	8	G
C224	5	D	C041	4	I	C604	6	G	D251	10	E	R240	3	D	R370	7	I
C225	4	E	C042	4	H	C605	6	I	D252	10	C	R241	3	D	R371	8	H
C226	3	E	C045	4	I	C606	6	G	D253	10	C	R243	3	E	R372	8	I
C227	4	F	C046	4	F	C607	6	I	D254	9	D	R244	3	C	R373	8	I
C228	4	F	C047	4	F	C608	6	G	D255	10	C	R252	9	D	R375	6	F
C229	4	E	C048	4	I	C609	6	I	D261	9	D	R253	9	D	R376	8	H
C230	4	E	C051	9	H	C610	6	G	D262	9	D	R255	9	E	R377	8	H
C231	3	E	C052	9	I	C611	3	I	D263	9	D	R254	9	E	R378	8	I
C232	4	C	C053	9	H	C612	6	G	D264	9	D	R255	9	B	R379	8	D
C233	4	C	C054	9	I	C613	6	I	D265	10	B	R256	9	E	R380	7	J
C234	4	C	C055	6	F	C614	6	G	D551	1	C	R262	9	B	R381	9	G
C235	5	C	C059	4	H	C615	7	I	D552	1	C	R263	10	B	R382	9	H
C236	5	C	C060	4	H	C616	7	G	D881	7	E	R284	10	B	R385	9	G
C237	4	C	C061	4	J	C617	6	H	D884	7	C	R265	10	B	R386	9	H
C238	3	D	C062	6	G	C618	7	H	D885	7	C	R266	9	C	R388	7	J
C239	3	D	C070	8	I	C619	7	H	D886	7	C	R301	1	J	R389	4	G
C240	4	E	C075	9	I	C620	7	C	D887	8	C	R302	1	J	R390	7	J
C241	4	E	C076	9	H	C621	5	I	D888	6	C	R303	2	J	R391	10	H
C242	4	E	C077	8	H	C622	5	I	F851	7	B	R304	2	J	R392	10	H
C243	4	C	C078	8	I	C623	4	I	F852	7	B	R305	2	J	R393	9	I
C244	4	C	C079	8	H	C624	5	I	FW211	6	B	R306	2	J	R394	9	I
C251	10	D	C080	8	I	C625	5	I	FW211B	9	B	R307	2	J	R395	10	D
C252	10	B	C081	9	H	C626	5	I	I0221	4	D	R308	2	J	R396	10	H
C253	10	E	C082	8	I	C627	5	I	I0222	4	E	R309	3	J	R395	1	C
C254	9	E	C083	9	G	C628	5	I	I0301	2	J	R310	3	I	R396	1	C
C255	9	E	C084	9	H	C631	5	G	I0305	9	H	R311	3	J	R397	1	D
C258	8	C	C085	9	G	C632	5	G	I0306	10	I	R312	3	J	R398	1	D
C260	9	E	C086	9	H	C633	5	H	I0307	9	G	R313	3	J	R399	1	E
C262	9	B	C087	8	G	C634	5	G	I0308	10	H	R314	3	J	R400	1	D
C264	9	D	C088	8	H	C641	6	J	I0311	4	H	R321	3	I	R501	1	D
C265	9	D	C090	8	G	C643	5	J	I0321	2	H	R322	3	I	R502	1	D
C266	10	B	C091	9	G	C644	6	J	I0551	2	C	R325	1	I	R503	1	C
C267	9	D	C092	9	G	C645	5	I	I0552	2	D	R326	1	I	R504	1	C
C268	9	C	C093	5	J	C646	6	I	I0601	5	H	R327	1	I	R505	2	C
C269	8	E	C094	5	G	C647	6	I	I0641	5	J	R328	1	I	R506	2	C
C300	1	J	C095	3	G	C648	6	I	J221	4	B	R329	1	H	R571	1	B
C301	1	J	C096	9	H	C649	5	J	J222	4	B	R330	1	H	R572	1	B
C302	1	J	C097	9	I	C650	5	I	J223	5	B	R331	1	H	R573	1	B
C303	2	J	C098	9	H	C651	5	I	J501	1	I	R332	1	H	R574	2	D
C304	2	J	C099	9	G	C652	5	I	J502	1	I	R333	1	H	R641	6	I
C305	2	J	C551	1	C	C653	10	H	J503	1	H	R334	1	H	R642	6	I
C306	2	I	C552	1	C	C654	10	I	L221	4	E	R335	1	H	R643	6	J
C307	3	J	C553	1	E	C655	10	G	Q221	4	D	R336	1	H	R644	6	J
C308	3	J	C554	1	D	C656	10	H	Q222	3	D	R337	1	F	R551	5	I
C309	2	J	C555	1	B	C681	7	D	Q223	3	D	R338	1	F	R552	7	I
C310	2	I	C556	1	C	C682	7	E	Q251	9	H	R341	3	I	R654	7	I
C311	3	J	C557	1	D	C683	7	E	Q252	10	E	R342	3	H	R662	9	G
C312	3	J	C558	1	D	C684	7	D	Q253	9	E	R343	4	I	R663	9	H
C313	2	J	C559	1	B	C685	8	D	Q254	9	E	R344	4	H	R666	6	F
C314	2	I	C560	1	C	C686	7	E	Q255	9	E	R347	4	I	R881	6	A
C315	3	J	C563	1	C	C6832	6	J	Q301	8	H	R348	4	H	R882	6	F
C316	3	J	C564	1	C	C6413	9	F	Q302	8	I	R349	4	J	R851	2	B
C319	2	G	C565	1	B	C6415	10	J	Q303	7	F	R350	4	J	R852	2	C
C320	2	H	C566	1	B	C6416	3	F	Q305	8	G	R351	9	H	R881	6	D
C321	2	G	C567	2	B	C6418	5	C	Q306	7	J	R352	9	I	J221	4	F
C322	2	H	C569	2	D	C6419	3	D	R221	4	C	R353	10	I	X641	5	I
C323	1	J	C570	2	D	C6420	3	J	R222	5	C	R354	10	I			
C324	1	J	C571	2	E	C6421	3	J	R223	4	C	R355	9	H			
C325	1	I	C572	2	D	C6422	3	J	R224	5	C	R356	9	I			
C326	1	I	C573	2	E	C6423	3	J	R225	4	C	R357	10	I			
C327	1	I	C574	2	D	C6424	3	J	R226	5	C	R358	10	I			
C328	1	I	C575	2	E	C6425	3	J	R227	3	C	R359	4	H			
C329	1	H	C576	2	D	C6426	3	J	R228	5	C	R360	4	H			

7 8 9 10

FRONT P.C.BOARD (ENB-252)

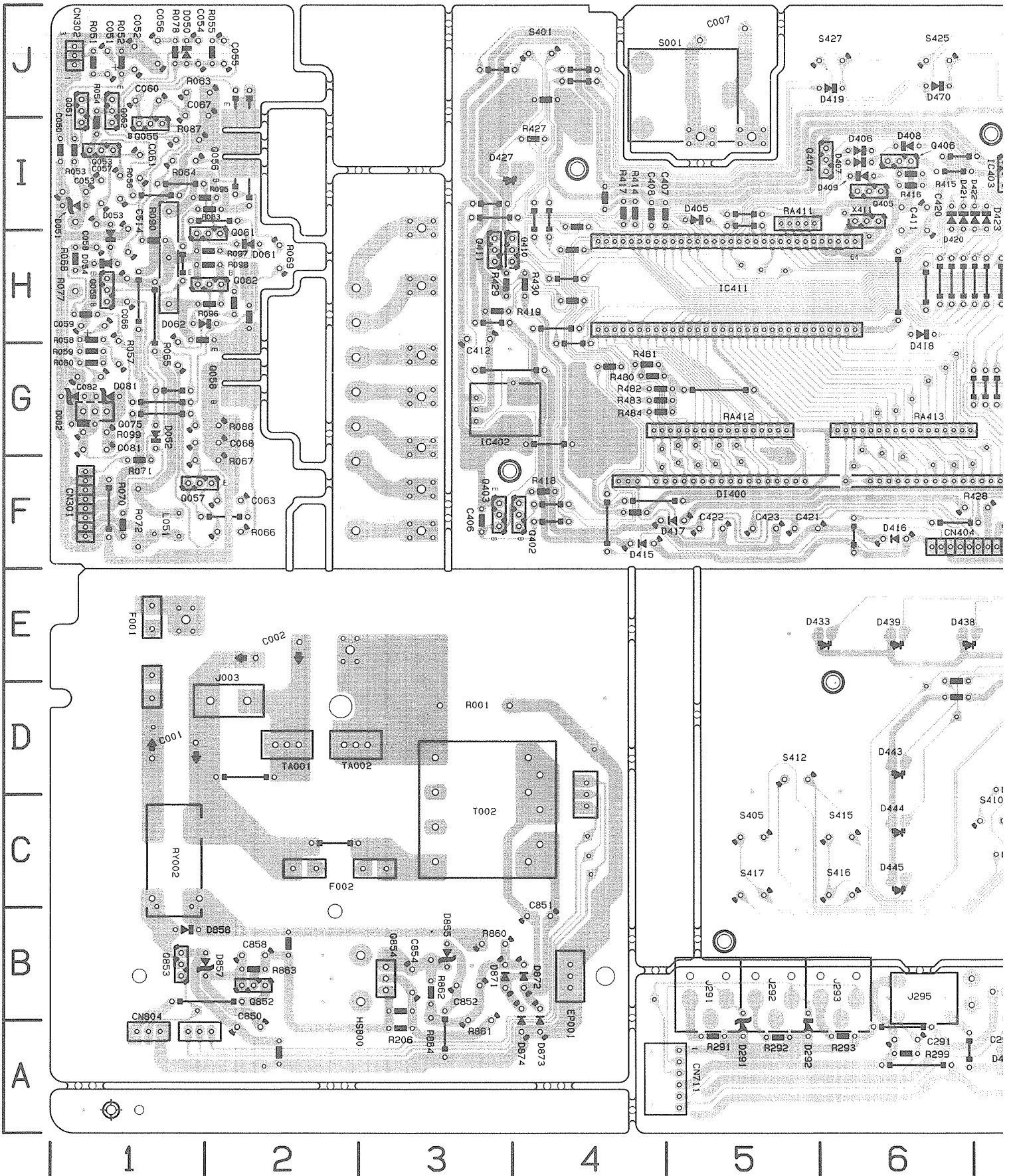



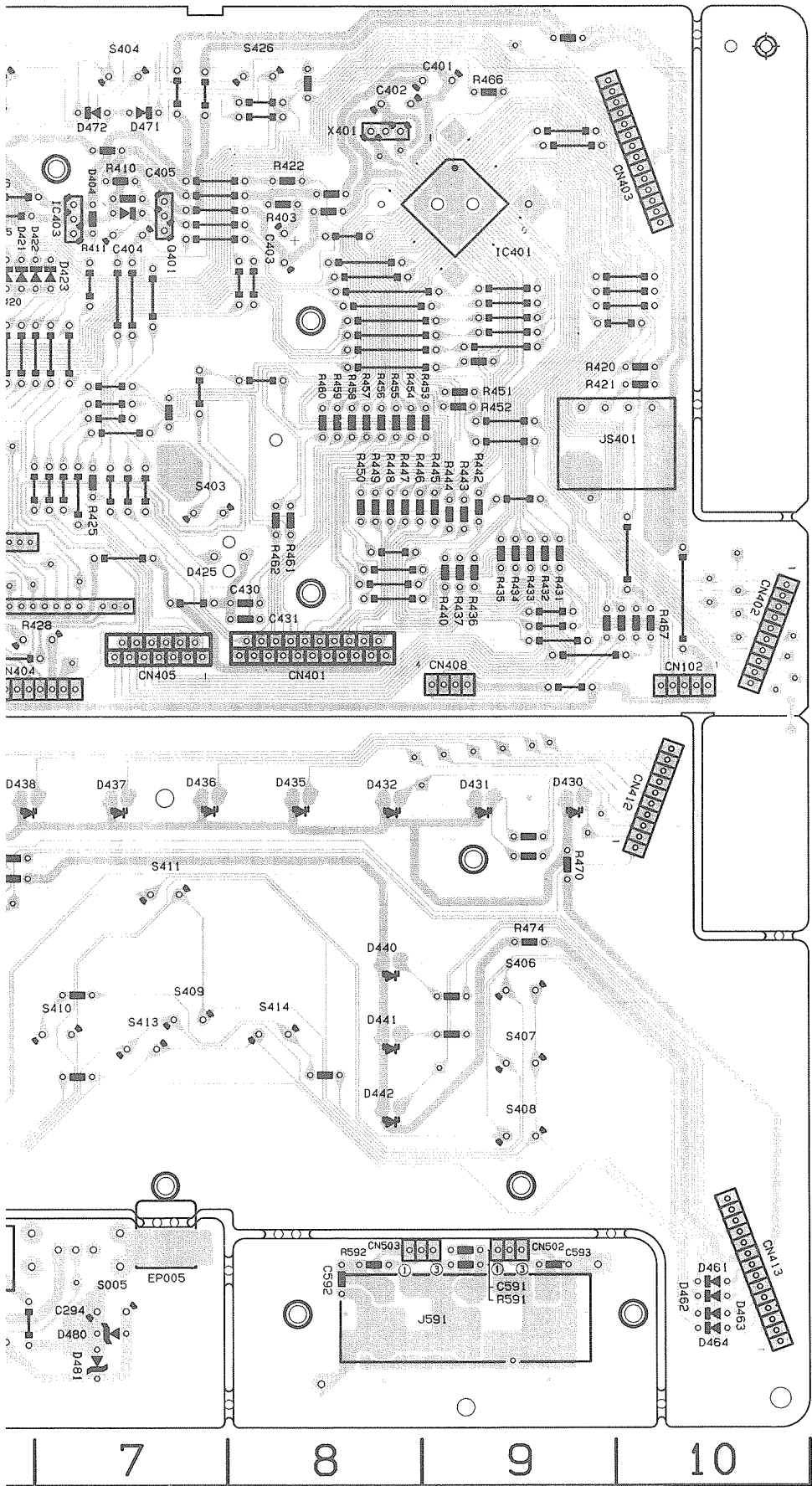

Location List (ENB-252)

Symbol	X	Y	Symbol	X	Y	Symbol	X	Y	Symbol	X	Y	Symbol	X	Y
C001	1	D	C08	10	F	D873	4	A	R097	2	H	RA413	6	G
C002	2	E	C09	5	H	D874	4	A	R098	2	H	RY002	1	C
C007	5	J	C0A	5	H	D1400	4	F	R099	1	G	RY102	1	C
C050	1	I	C0B	9	E	F001	1	E	R206	3	A	S001	4	J
C051	1	J	C0C	9	E	F002	2	C	R291	5	A	S005	7	B
C052	1	J	C0D	9	E	IC401	9	I	R292	5	A	S401	4	J
C053	1	I	C0E	9	E	IC402	4	G	R293	6	A	S403	7	G
C054	1	J	C0F	8	E	IC403	7	I	R299	6	A	S404	7	J
C055	2	J	C0H	9	E	IC411	6	H	R403	8	I	S405	5	C
C056	1	J	C0I	9	E	J003	2	D	R410	7	I	S406	9	D
C057	1	I	C0J	9	E	J291	5	B	R411	7	I	S407	9	C
C058	1	H	C0K	9	E	J292	5	B	R414	4	I	S408	9	C
C059	1	H	C0L	6	D	J293	6	B	R415	6	I	S409	7	E
C060	1	J	C0M	6	D	J295	6	B	R416	6	I	S410	7	C
C061	1	I	C0N	9	G	J591	9	A	R417	4	I	S411	7	D
C063	2	F	C0S0	1	J	JS401	10	G	R418	4	F	S412	5	D
C066	1	H	C0S1	1	I	L051	1	F	R419	3	H	S413	7	C
C067	2	J	C0S2	1	G	P1	5	I	R420	10	H	S414	8	C
C068	2	G	C0S3	1	I	P2	5	I	R421	10	H	S415	6	C
C081	1	G	C0S4	1	H	P206	1	A	R422	8	I	S416	6	C
C082	1	G	D061	2	H	P207	4	C	R425	7	G	S417	5	C
C291	6	A	D062	1	H	O051	1	I	R427	4	I	S425	6	J
C294	7	A	D081	1	G	O052	1	I	R428	6	F	S426	8	J
C401	9	J	D082	1	G	O053	1	I	R429	3	H	S427	6	J
C402	8	J	D291	5	A	O055	1	I	R430	4	H	T002	3	C
C403	8	I	D292	5	A	O056	2	I	R431	9	A	TA001	2	D
C404	7	I	D404	7	I	O057	1	F	R432	9	G	TA002	2	D
C405	7	I	D405	5	I	O058	2	G	R433	9	G	X401	8	J
C406	3	F	D406	6	I	O059	1	H	R434	9	G	X411	6	I
C407	4	I	D407	6	I	O061	2	H	R435	9	G			
C408	4	I	D408	6	I	O062	2	H	R436	9	G			
C411	6	I	D409	6	I	O075	1	G	R437	9	G			
C412	3	H	D415	4	F	Q401	7	I	R440	9	G			
C420	6	I	D416	6	F	Q402	4	F	R442	9	G			
C421	5	F	D417	5	F	Q403	3	F	R443	9	G			
C422	5	F	D418	6	H	Q404	6	I	R444	9	G			
C423	5	F	D419	5	J	Q405	6	I	R445	9	G			
C430	8	F	D420	6	I	Q406	6	I	R446	8	G			
C431	8	F	D421	6	I	Q410	3	H	R447	8	G			
C514	1	H	D422	7	I	Q411	3	H	R448	8	G			
C591	9	B	D423	7	I	Q852	2	B	R449	8	G			
C592	8	A	D425	7	G	Q853	1	B	R450	8	G			
C593	9	B	D427	3	I	Q854	3	B	R451	9	H			
C850	2	A	D430	9	E	R001	3	D	R452	9	H			
C851	4	B	D431	9	E	R051	1	J	R453	9	H			
C852	3	B	D432	8	E	R052	1	J	R454	8	H			
C854	3	B	D433	6	E	R053	1	I	R455	8	H			
C858	2	B	D435	8	E	R054	1	I	R456	8	H			
CH10	5	H	D436	7	E	R055	2	J	R457	8	H			
CN102	10	F	D437	7	E	R056	1	I	R458	8	H			
CN301	1	F	D438	6	E	R057	1	G	R459	8	H			
CN302	1	J	D439	6	E	R058	1	H	R460	8	H			
CN401	8	F	D440	8	D	R059	1	G	R461	8	G			
CN402	10	F	D441	8	C	R060	1	G	R462	8	G			
CN403	10	I	D442	8	C	R063	2	J	R466	9	J			
CN404	6	F	D443	6	D	R064	1	I	R467	10	F			
CN405	7	F	D444	6	C	R065	1	G	R470	9	E			
CN408	9	F	D445	6	C	R066	2	F	R474	9	D			
CN412	10	E	D461	10	B	R067	2	F	R480	4	G			
CN413	10	A	D462	10	A	R068	1	H	R481	4	G			
CN502	9	B	D463	10	A	R069	2	H	R482	5	G			
CN503	9	B	D464	10	A	R070	1	F	R483	5	C			
CN711	5	A	D470	6	J	R071	1	F	R484	5	G			
CN804	1	A	D471	7	J	R072	1	F	R591	9	B			
C00	10	F	D472	7	J	R077	1	H	R592	8	B			
C01	10	F	D480	7	A	R078	1	J	R860	3	B			
C02	10	F	D481	7	A	R083	2	I	R861	3	B			
C03	10	F	D855	3	B	R087	1	I	R862	3	B			
C04	10	G	D857	2	B	R088	2	G	R863	2	B			
C05	10	F	D858	1	B	R090	1	H	R864	3	B			
C06	10	F	D871	3	B	R095	1	I	RA411	5	I			
C07	10	F	D872	4	B	R096	1	H	RA412	5	G			

TUNER P.C.BOARD (ENA-178)

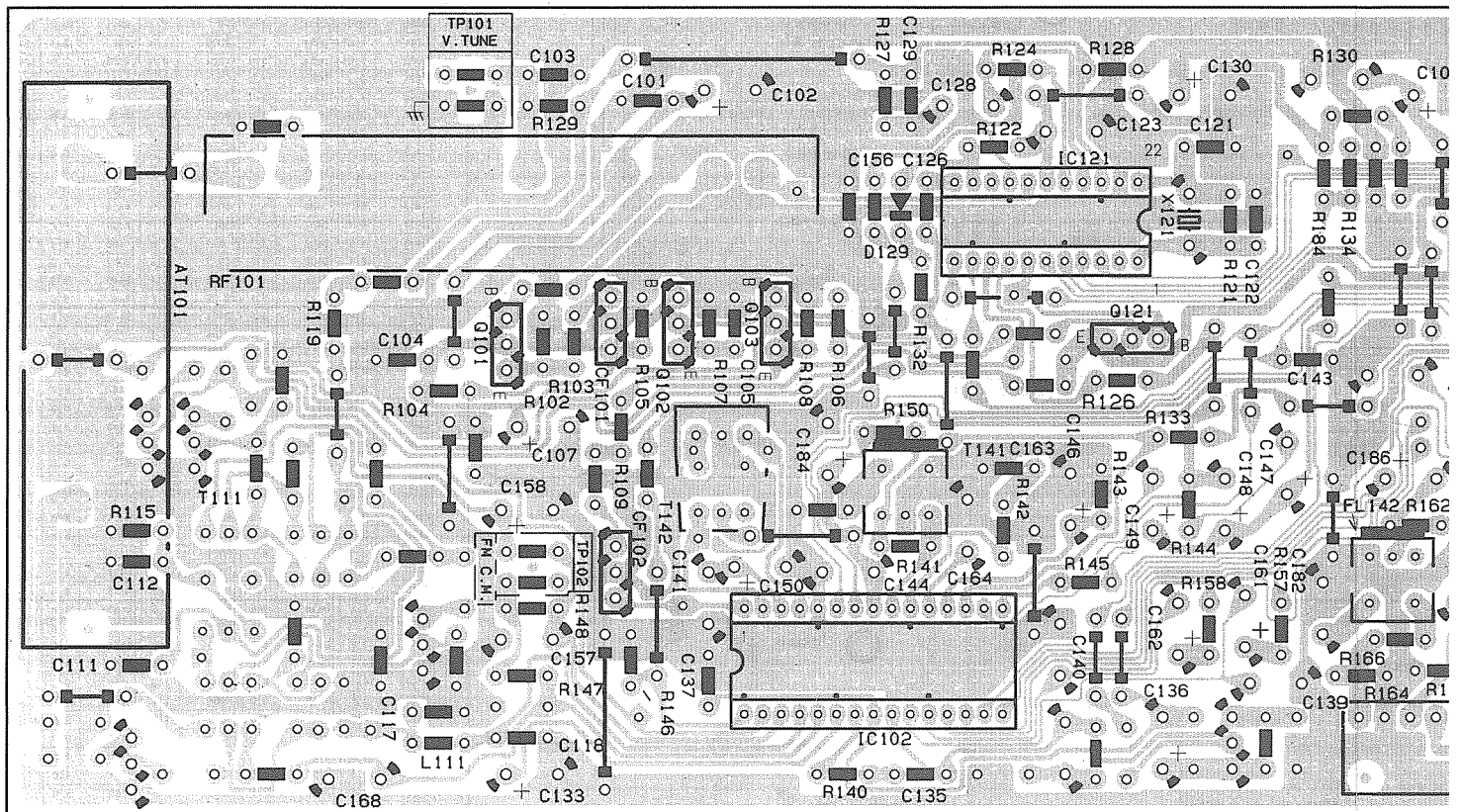

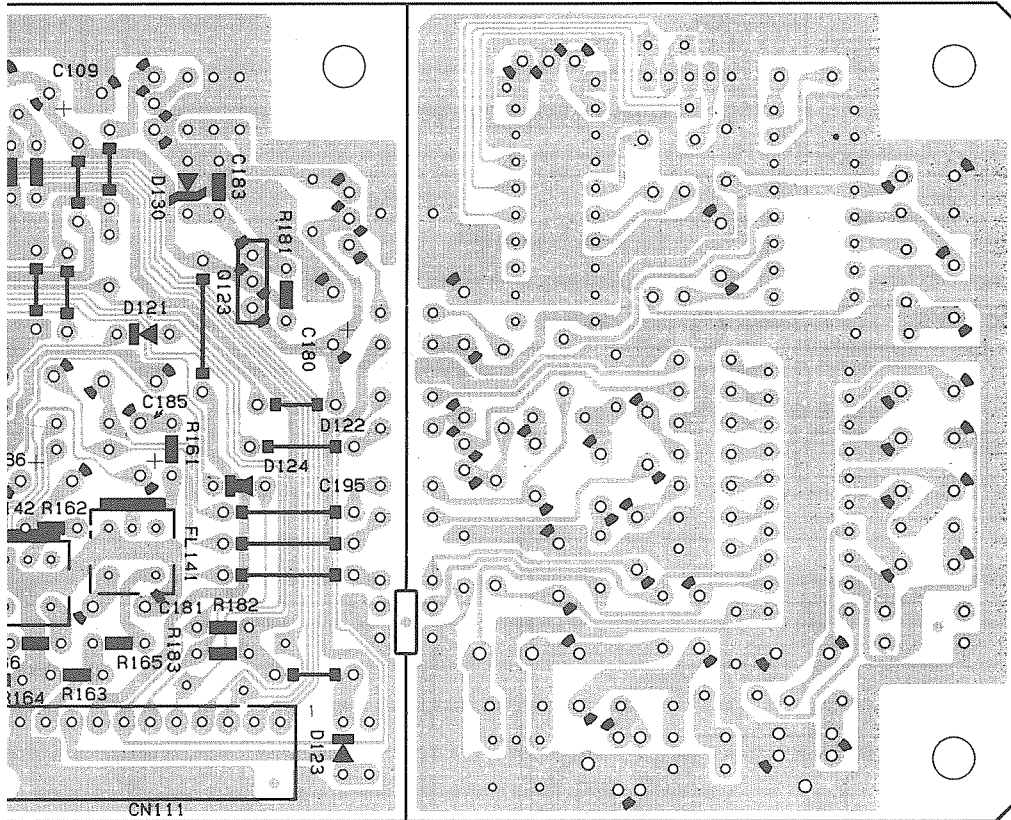

Location List (EMA-178)

Symbol	X	Y	Symbol	X	Y	Symbol	X	Y
C101	3	E	C192	10	D	R140	4	A
C102	4	E	C193	9	E	R141	4	C
C103	3	E	C194	9	E	R142	5	C
C104	2	D	C195	8	C	R143	5	C
C105	4	D	C196	9	D	R144	5	C
C107	3	C	C197	8	D	R145	5	B
C109	6	E	C199	10	E	R146	3	B
C111	1	B	CF101	3	D	R147	3	B
C112	1	B	CF102	3	C	R148	3	B
C113	1	A	CN111	6	B	R149	3	B
C117	3	B	CN112	9	E	R150	4	C
C118	3	A	D121	7	D	R151	8	C
C121	5	E	D122	8	C	R152	8	B
C122	6	D	D123	7	A	R153	8	B
C123	5	E	D124	7	C	R155	8	C
C126	4	E	D129	4	E	R156	9	C
C128	5	E	D130	7	E	R157	8	B
C129	4	E	D131	8	A	R158	8	B
C130	5	E	D132	9	D	R159	7	C
C131	9	C	D133	7	E	R160	7	C
C132	9	B	FL141	7	C	R161	7	C
C133	3	A	FL142	6	B	R162	6	C
C135	4	A	IC102	4	B	R163	6	B
C136	5	A	IC104	9	B	R164	6	B
C137	4	B	IC121	5	D	R165	6	B
C138	5	A	IC191	8	E	R166	6	B
C139	8	B	IC192	9	D	R167	7	E
C140	5	B	L111	2	A	R168	7	E
C141	4	B	Q101	3	D	R170	9	B
C143	6	D	Q102	3	D	R171	9	B
C144	4	B	Q103	4	D	R172	8	B
C146	5	C	Q111	2	B	R173	9	B
C147	6	C	Q112	2	C	R176	9	C
C148	6	C	Q113	1	C	R177	10	C
C149	5	C	Q114	1	A	R178	9	B
C150	4	B	Q121	5	D	R179	9	A
C153	6	B	Q123	7	D	R181	7	D
C154	8	C	Q131	8	C	R182	7	B
C155	5	A	Q132	6	B	R183	7	B
C156	4	E	Q133	7	D	R184	6	D
C157	3	B	Q134	7	E	R191	10	D
C158	3	C	R102	3	D	RF101	2	E
C159	7	C	R103	3	D	T111	2	B
C160	6	C	R104	2	C	T141	4	C
C161	6	B	R105	3	D	T142	4	C
C162	5	B	R106	4	D	T151	8	A
C163	5	C	R107	4	D	TC101	8	B
C164	5	C	R108	4	D	X121	5	D
C165	7	E	R109	3	C	X191	10	D
C166	8	B	R110	1	A	X192	8	E
C167	9	B	R111	3	B			
C168	2	A	R112	2	D			
C170	8	C	R113	2	D			
C171	8	B	R114	2	C			
C172	9	B	R115	1	C			
C173	9	C	R116	1	B			
C174	9	C	R119	2	D			
C177	9	C	R121	6	D			
C178	10	C	R122	5	E			
C179	10	C	R124	5	E			
C180	7	D	R126	5	C			
C181	6	B	R127	4	E			
C182	6	B	R128	5	E			
C183	7	D	R129	3	E			
C184	4	C	R130	6	E			
C185	7	C	R131	5	D			
C186	6	C	R132	4	D			
C187	9	B	R133	6	C			
C188	10	C	R134	6	E			
C189	10	B	R137	7	D			
C190	9	B	R138	5	B			
C191	9	D	R139	5	B			



P2-29-a

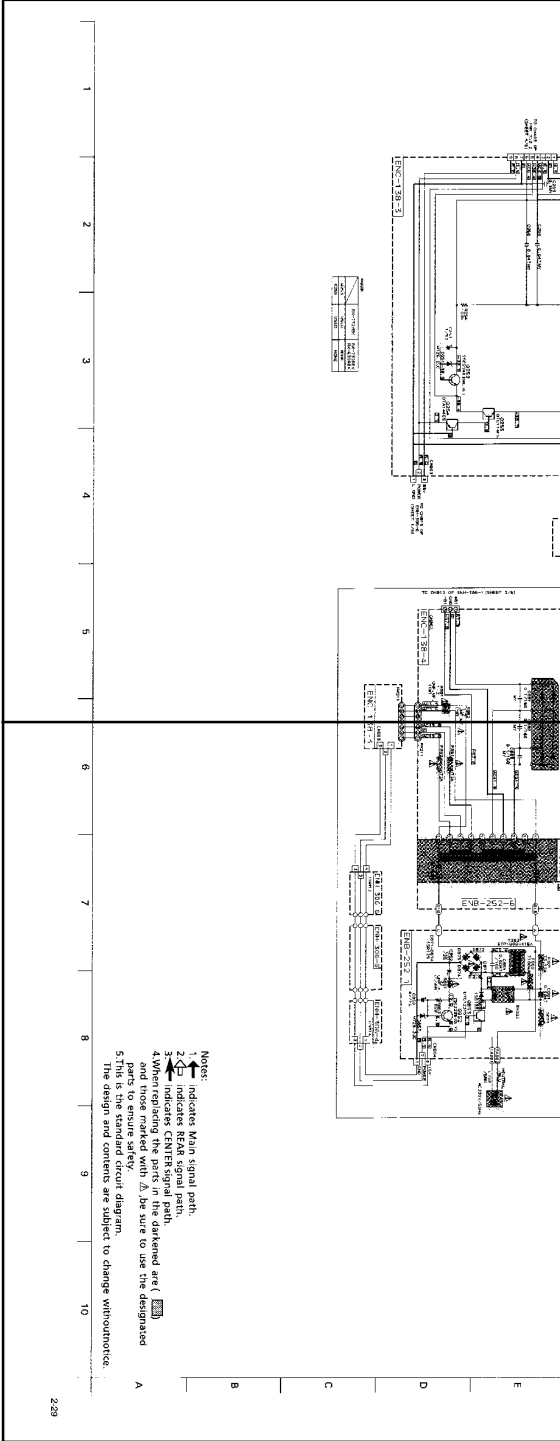

P2-29-b

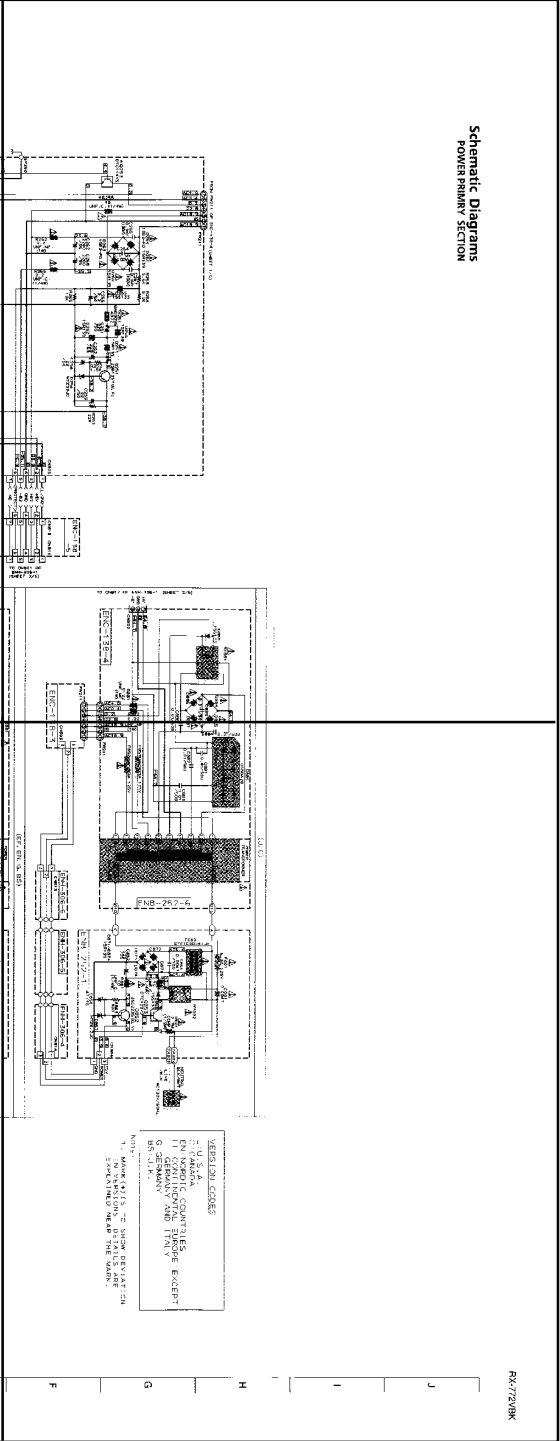

P2-29-c

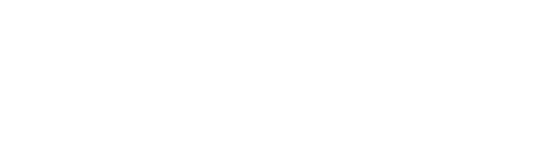

P2-29-d



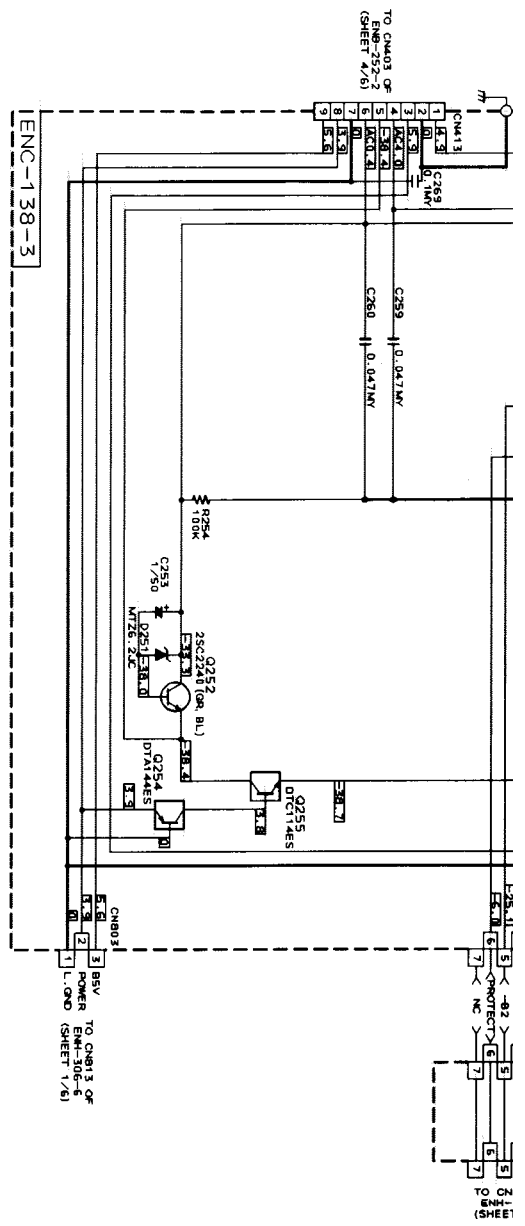

MARK



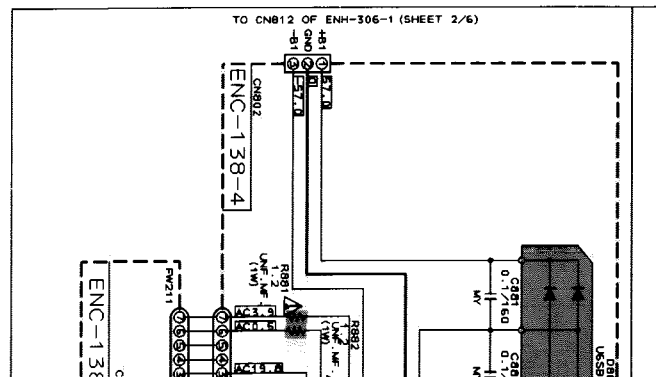

RX-772V/BK	RX-730R/BK
Q253	USED
R255	USED
	NONE
	NONE

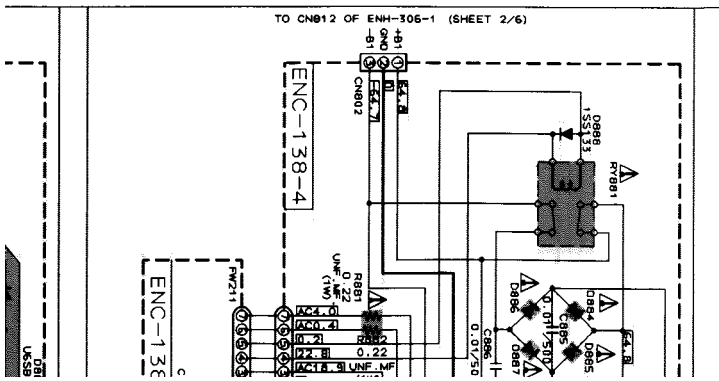
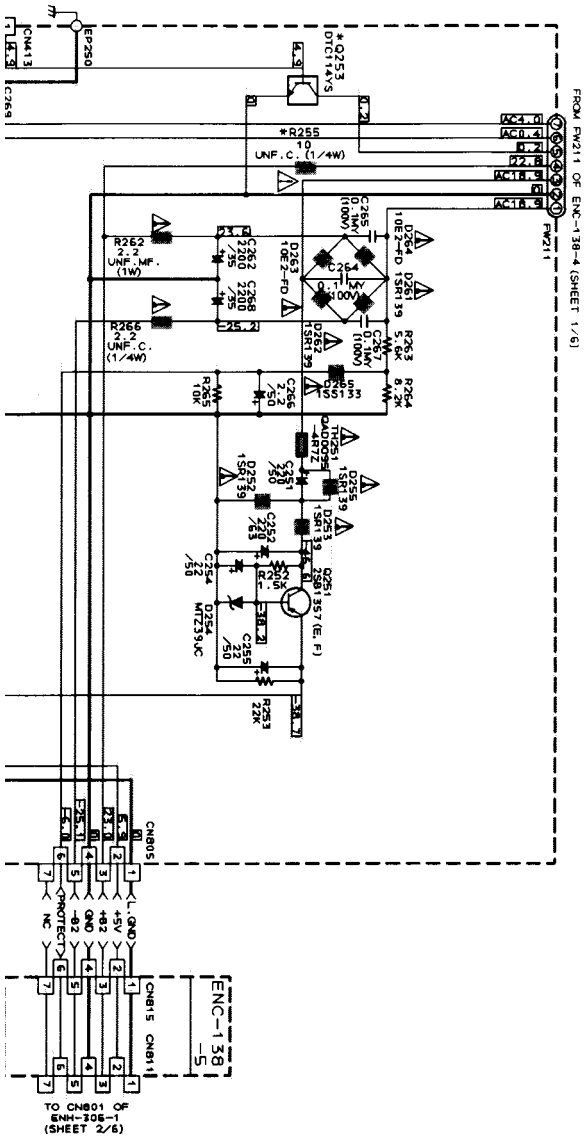

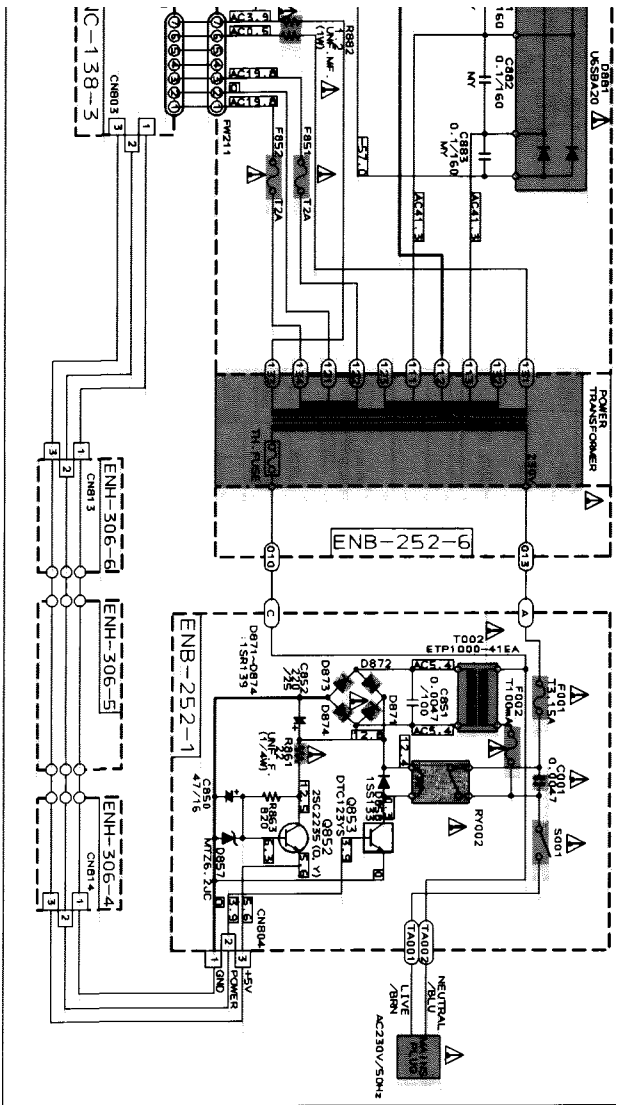
# Schematic Diagrams POWER PRIMARY SECTION





- Notes:
1.  indicates Main signal path.
  2.  indicates REAR signal path.
  3.  indicates CENTER signal path.
  4. When replacing the parts in the darkened are (  ) and those marked with  , be sure to use the designated parts to ensure safety.
  5. This is the standard circuit diagram. The design and contents are subject to change without notice.

6

7

8

9

10

A

B

C

D

E



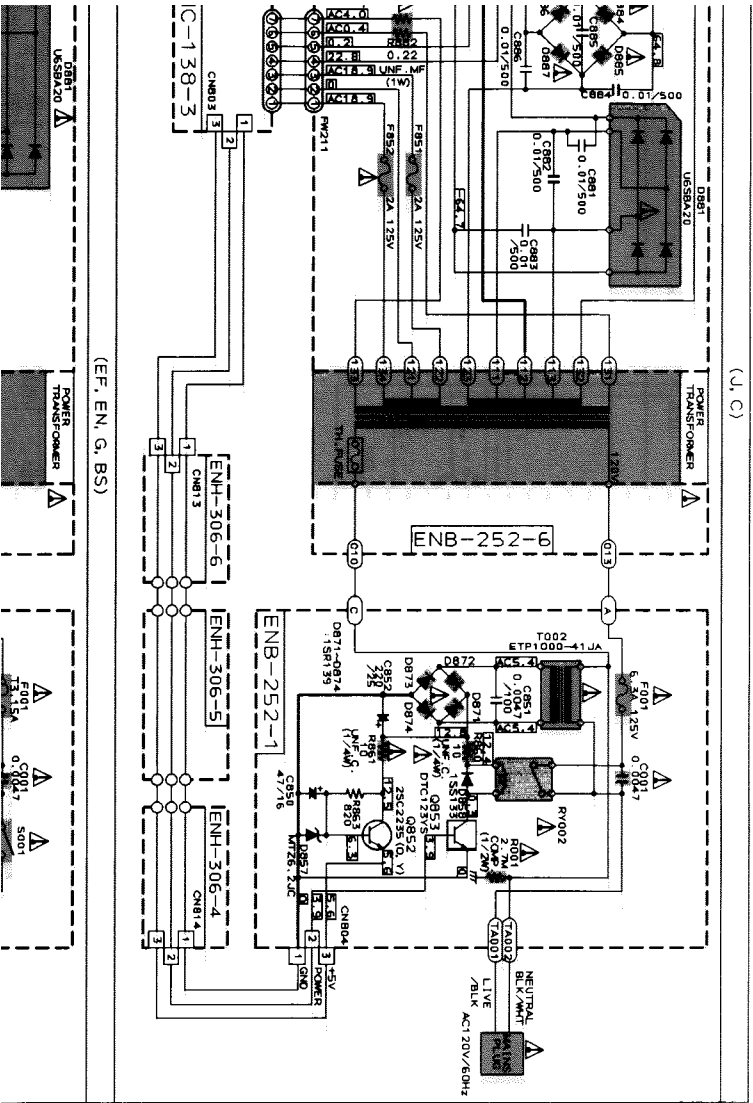

(J, C)

(EF, EN, G, BS)

VERSION CODES  
 J: U.S.A.  
 C: CANADA  
 EN: NORDIC COUNTRIES  
 EF: CONTINENTAL EUROPE EXCEPT GERMANY AND ITALY  
 G: GERMANY  
 BS: U.K.

NOTE:  
 1. MARK (\*) IS TO SHOW DEVIATION IN VERSIONS. DETAILS ARE EXPLAINED NEAR THE MARK.

F	G	H	I	J
---	---	---	---	---



P2-30-a

P2-30-b

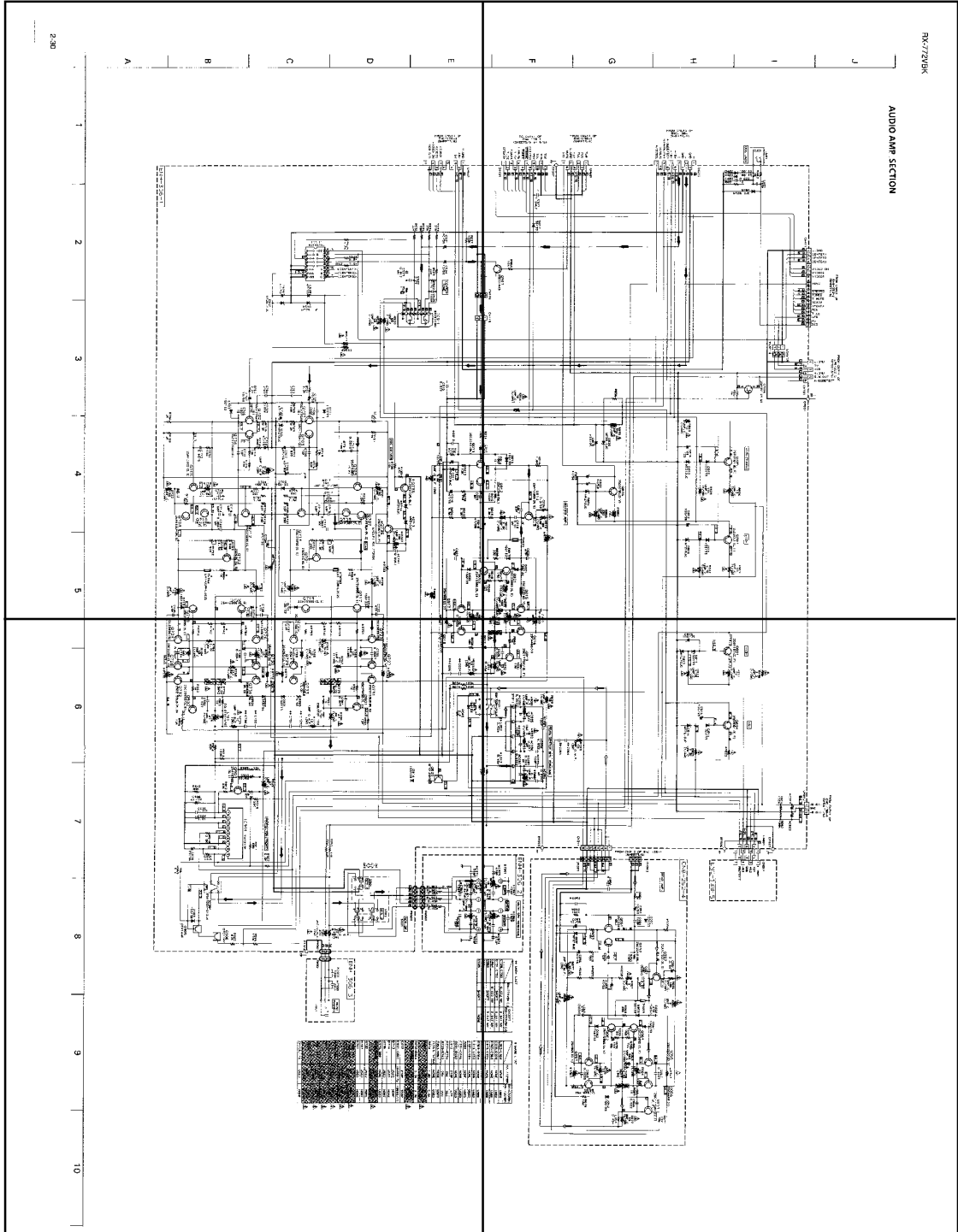

P2-30-c

P2-30-d

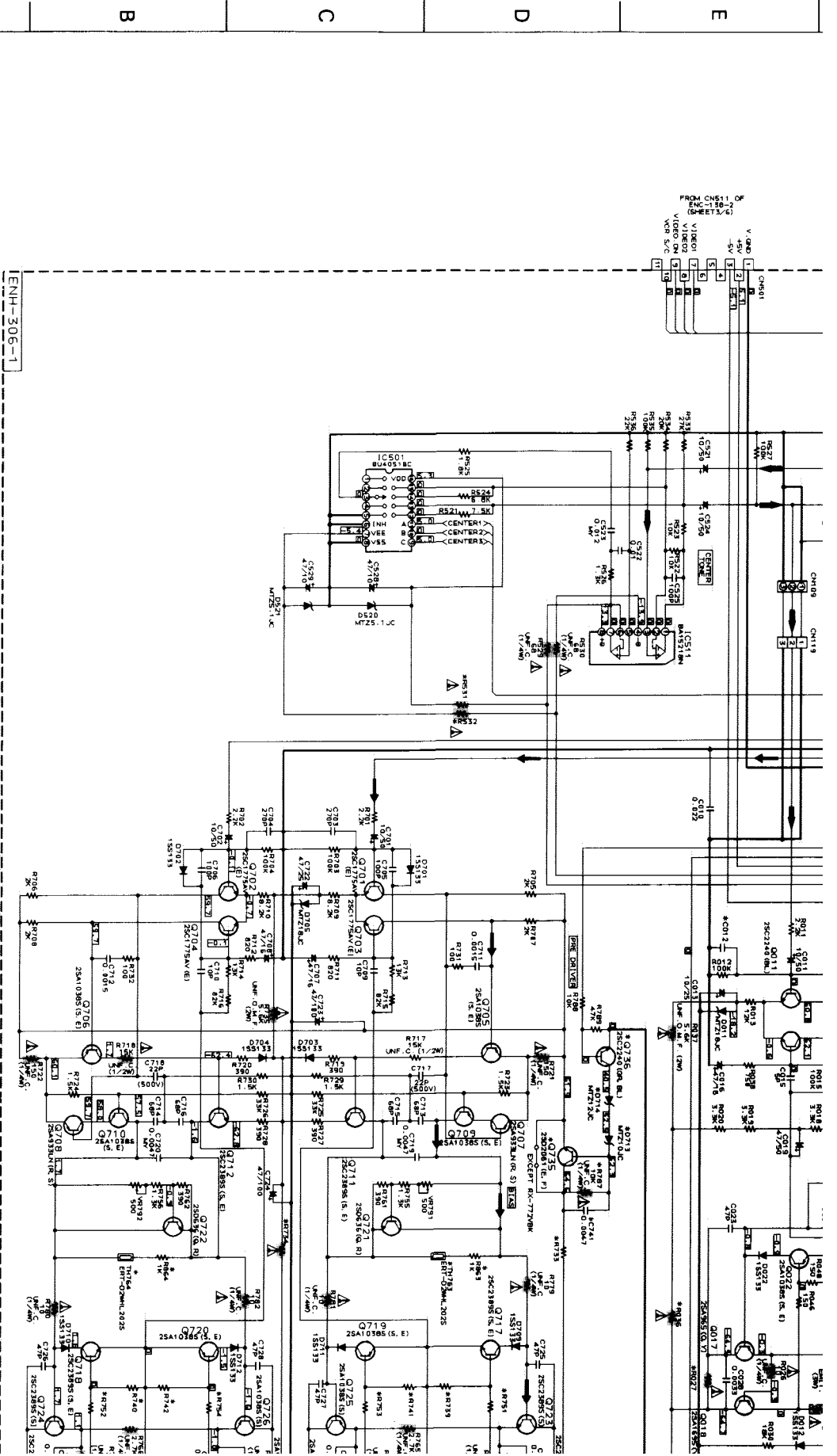

ENH-306-1

1 2 3 4 5

AUDIO AMP SECTION

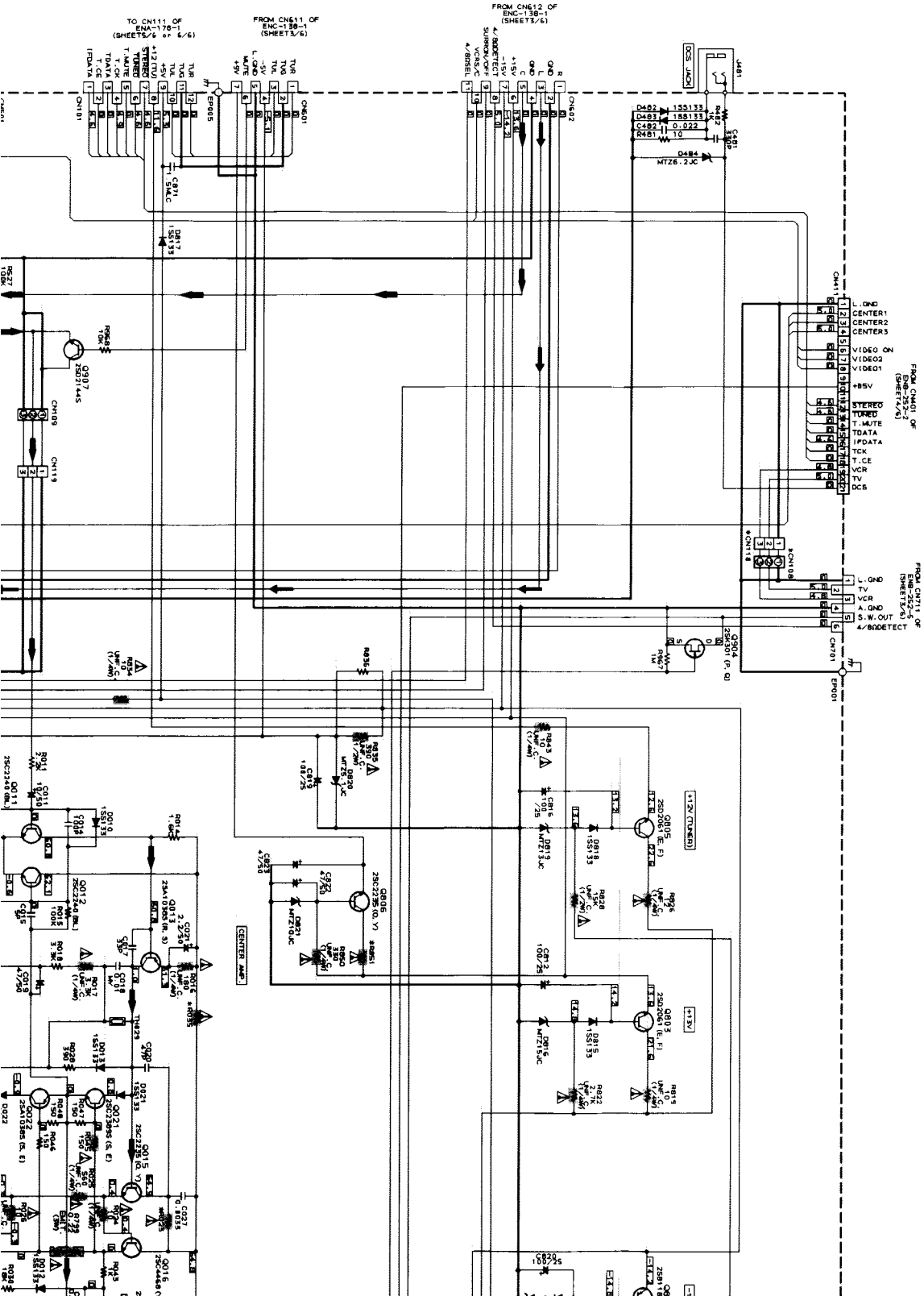



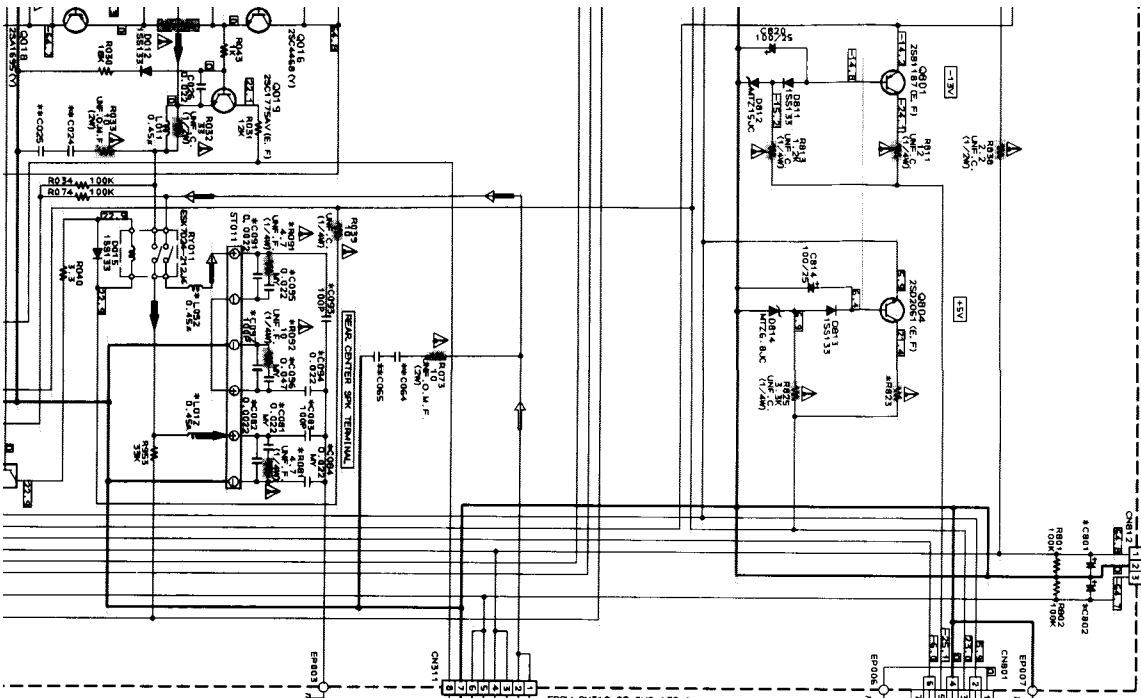

FROM CHART OF SHEET 7/6  
 1  
 2  
 3  
 4  
 5  
 6  
 7  
 8  
 9  
 10  
 11  
 12  
 13  
 14  
 15  
 16  
 17  
 18  
 19  
 20  
 21  
 22  
 23  
 24  
 25  
 26  
 27  
 28  
 29  
 30  
 31  
 32  
 33  
 34  
 35  
 36  
 37  
 38  
 39  
 40  
 41  
 42  
 43  
 44  
 45  
 46  
 47  
 48  
 49  
 50  
 51  
 52  
 53  
 54  
 55  
 56  
 57  
 58  
 59  
 60  
 61  
 62  
 63  
 64  
 65  
 66  
 67  
 68  
 69  
 70  
 71  
 72  
 73  
 74  
 75  
 76  
 77  
 78  
 79  
 80  
 81  
 82  
 83  
 84  
 85  
 86  
 87  
 88  
 89  
 90  
 91  
 92  
 93  
 94  
 95  
 96  
 97  
 98  
 99  
 100

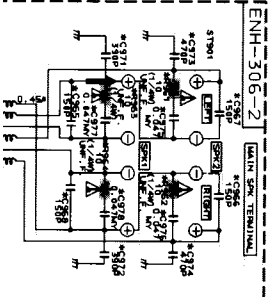

# MARK LIST

MARK	DESCRIPTION	EXCEPT
0025	SHORT	NONE
0024	0.447 MV	NONE
0023	0.447 MV	NONE
0022	0.447 MV	NONE
0021	0.447 MV	NONE
0020	0.447 MV	NONE
0019	0.447 MV	NONE
0018	0.447 MV	NONE
0017	0.447 MV	NONE
0016	0.447 MV	NONE
0015	0.447 MV	NONE
0014	0.447 MV	NONE
0013	0.447 MV	NONE
0012	0.447 MV	NONE
0011	0.447 MV	NONE
0010	0.447 MV	NONE
0009	0.447 MV	NONE
0008	0.447 MV	NONE
0007	0.447 MV	NONE
0006	0.447 MV	NONE
0005	0.447 MV	NONE
0004	0.447 MV	NONE
0003	0.447 MV	NONE
0002	0.447 MV	NONE
0001	0.447 MV	NONE

# MARK LIST

MARK	DESCRIPTION	EXCEPT
0025	SHORT	NONE
0024	0.447 MV	NONE
0023	0.447 MV	NONE
0022	0.447 MV	NONE
0021	0.447 MV	NONE
0020	0.447 MV	NONE
0019	0.447 MV	NONE
0018	0.447 MV	NONE
0017	0.447 MV	NONE
0016	0.447 MV	NONE
0015	0.447 MV	NONE
0014	0.447 MV	NONE
0013	0.447 MV	NONE
0012	0.447 MV	NONE
0011	0.447 MV	NONE
0010	0.447 MV	NONE
0009	0.447 MV	NONE
0008	0.447 MV	NONE
0007	0.447 MV	NONE
0006	0.447 MV	NONE
0005	0.447 MV	NONE
0004	0.447 MV	NONE
0003	0.447 MV	NONE
0002	0.447 MV	NONE
0001	0.447 MV	NONE

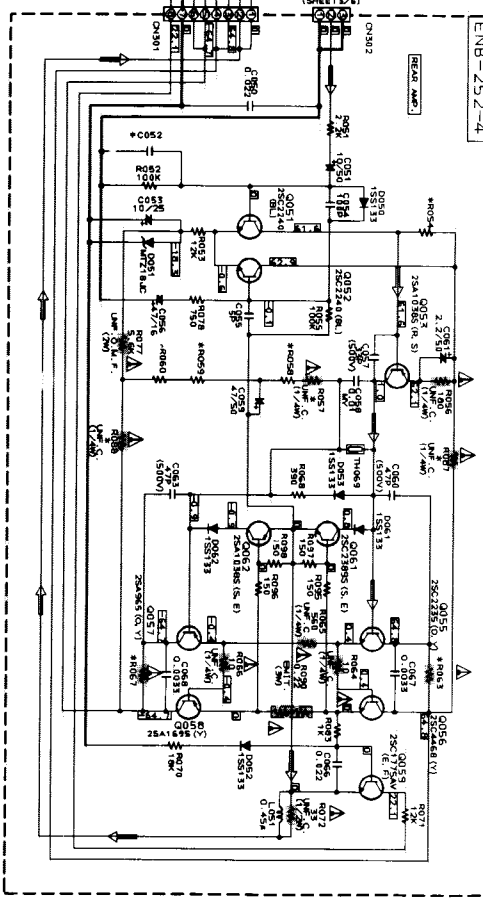





P2-31-a

P2-31-b

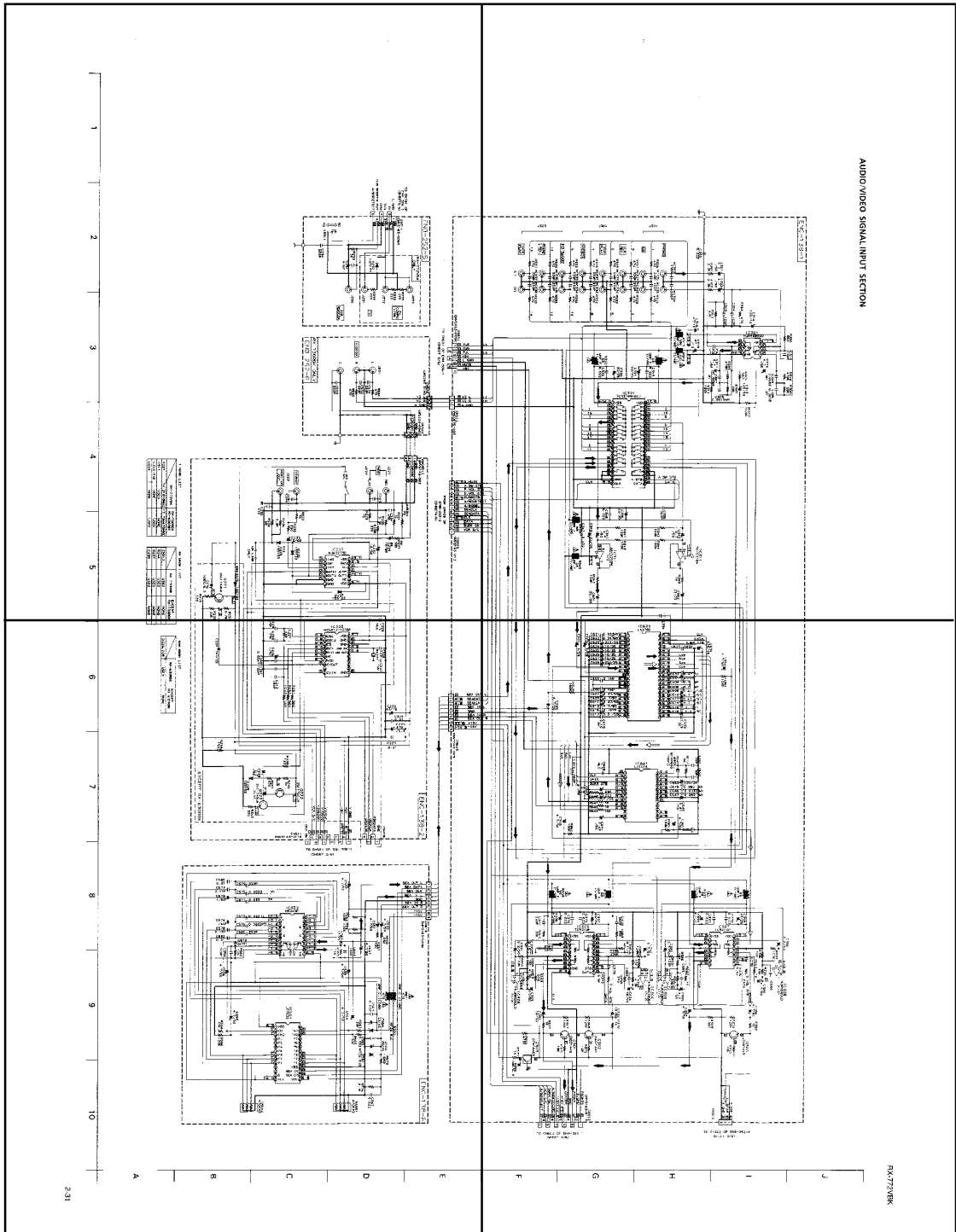

P2-31-c

P2-31-d

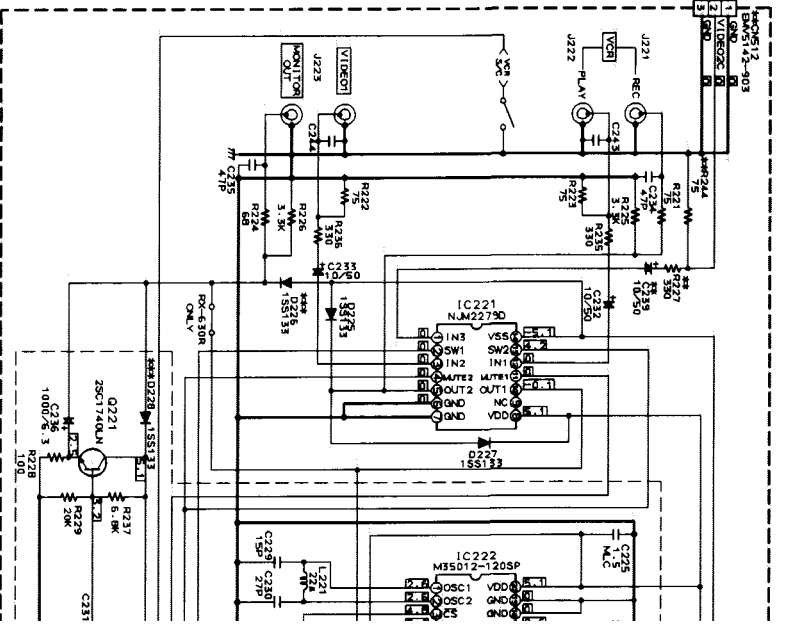
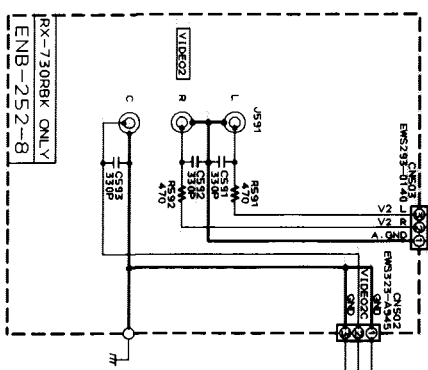
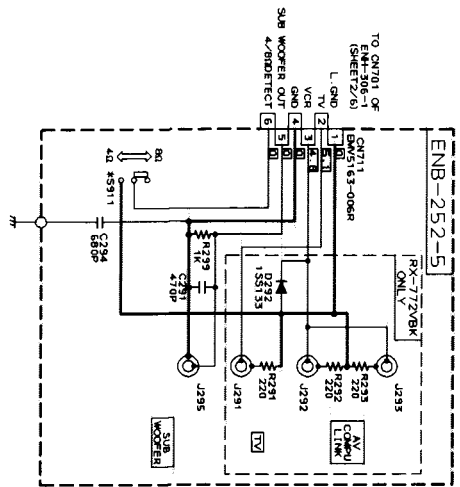
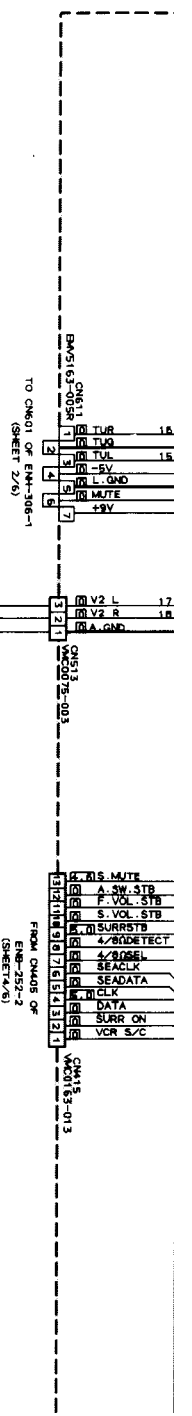

\* MARK LIST

	RX-772VBRK	RX-730RBRK
X221	USED	NONE
R311	USED	NONE
C323-338	NONE	USED
D224	NONE	USED

\*\* MARK LIST

	RX-730RBRK	EXCEPT
CN512	USED	NONE
R244	USED	NONE
R227	USED	NONE
C235	USED	NONE
D221	USED	NONE

AUDIO/VIDEO SIGNAL INPUT SECTION

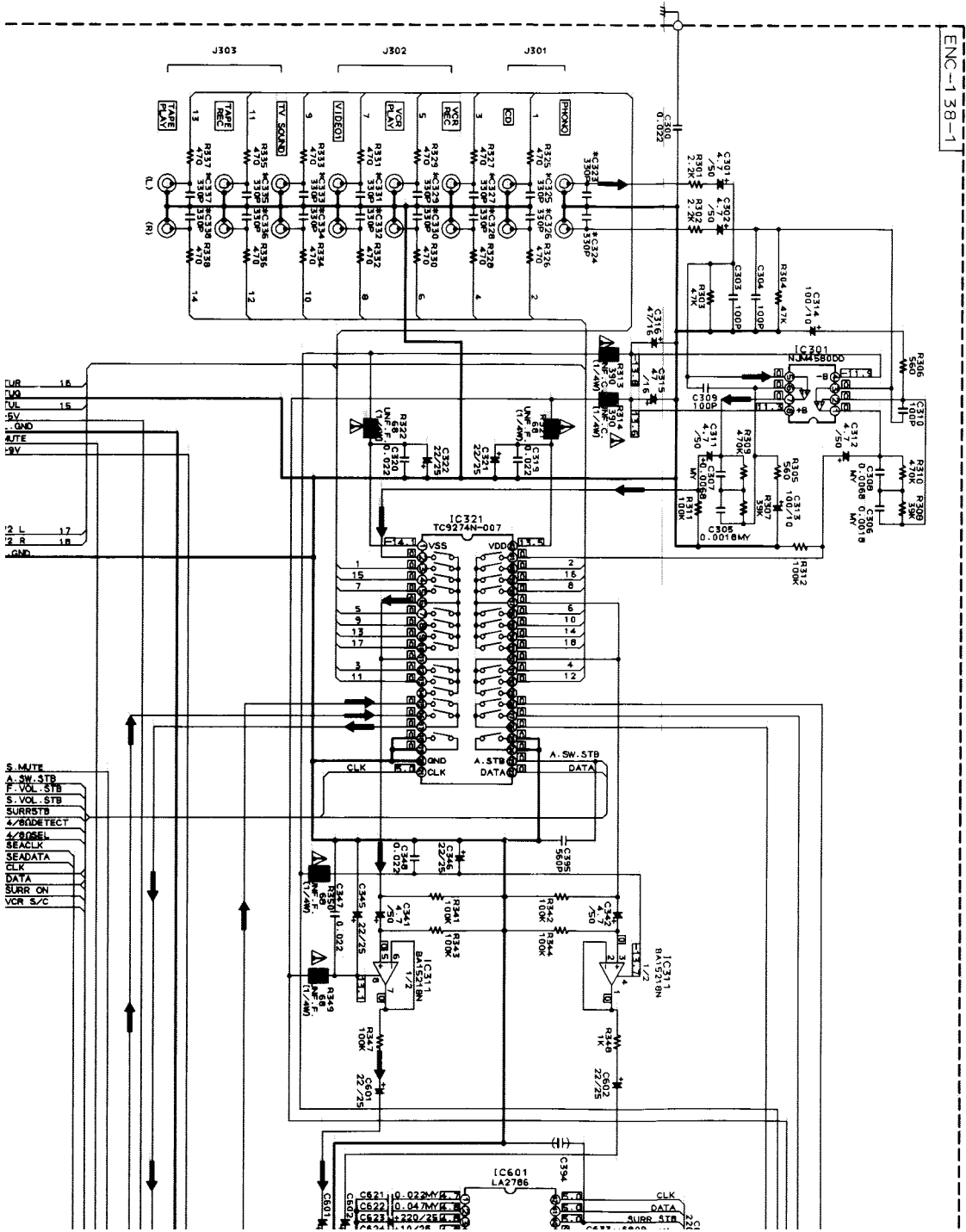

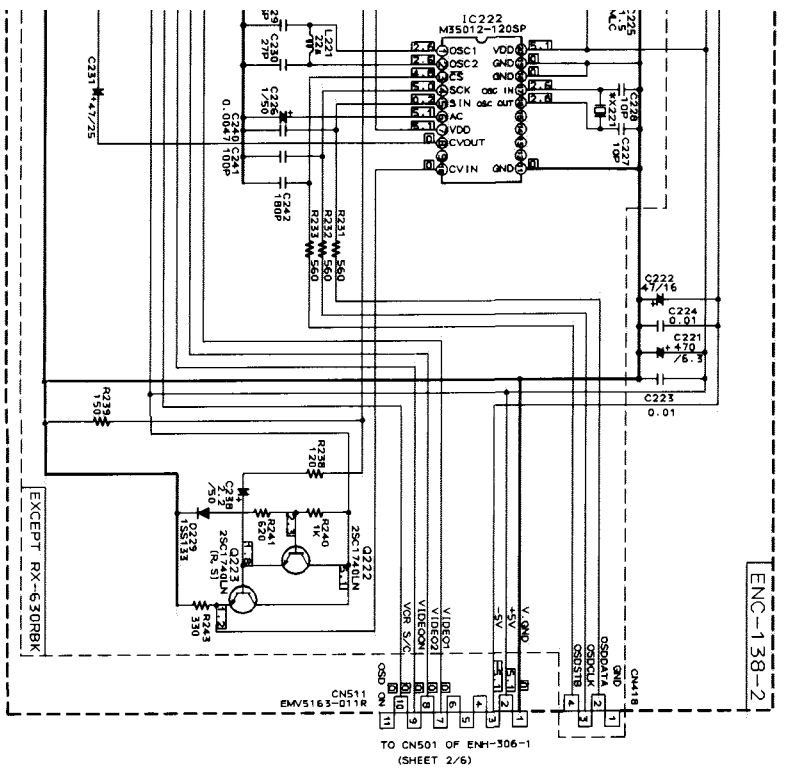
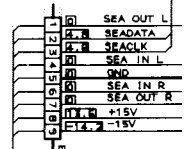

3348 MARK LIST

	RX-6308BK	EXCEPT	RX-6308BK
D226, 228	USED		NONE

ENC-138-2

TO CN501 OF ENH-306-1  
(SHEET 2/6)

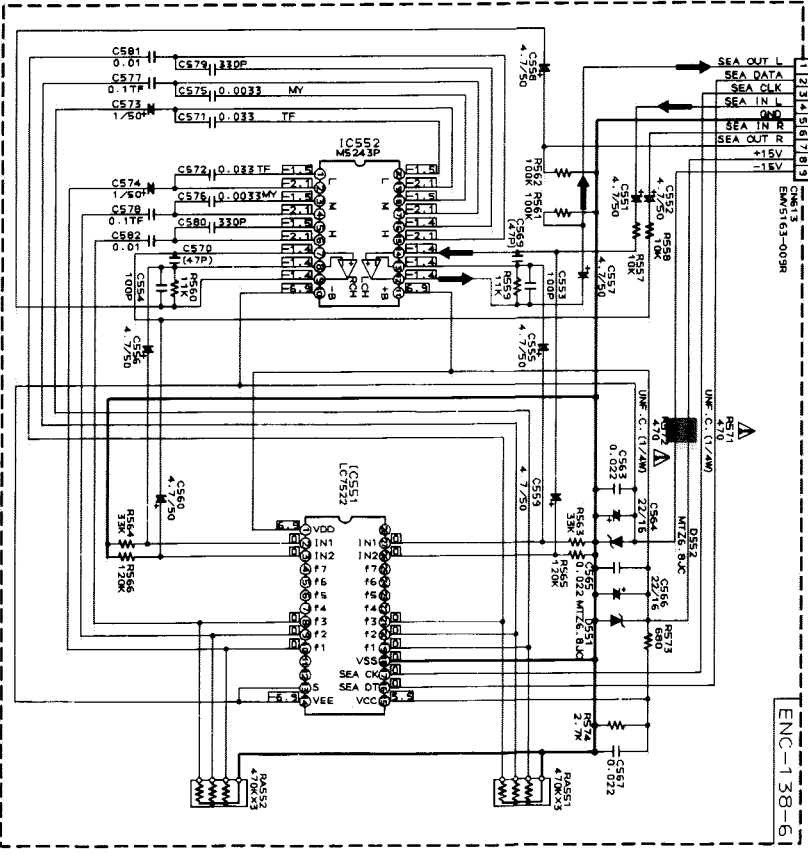
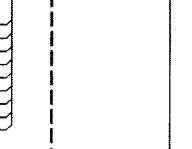

ENC-138-6

6 7 8 9 10

A

B

C

D

E

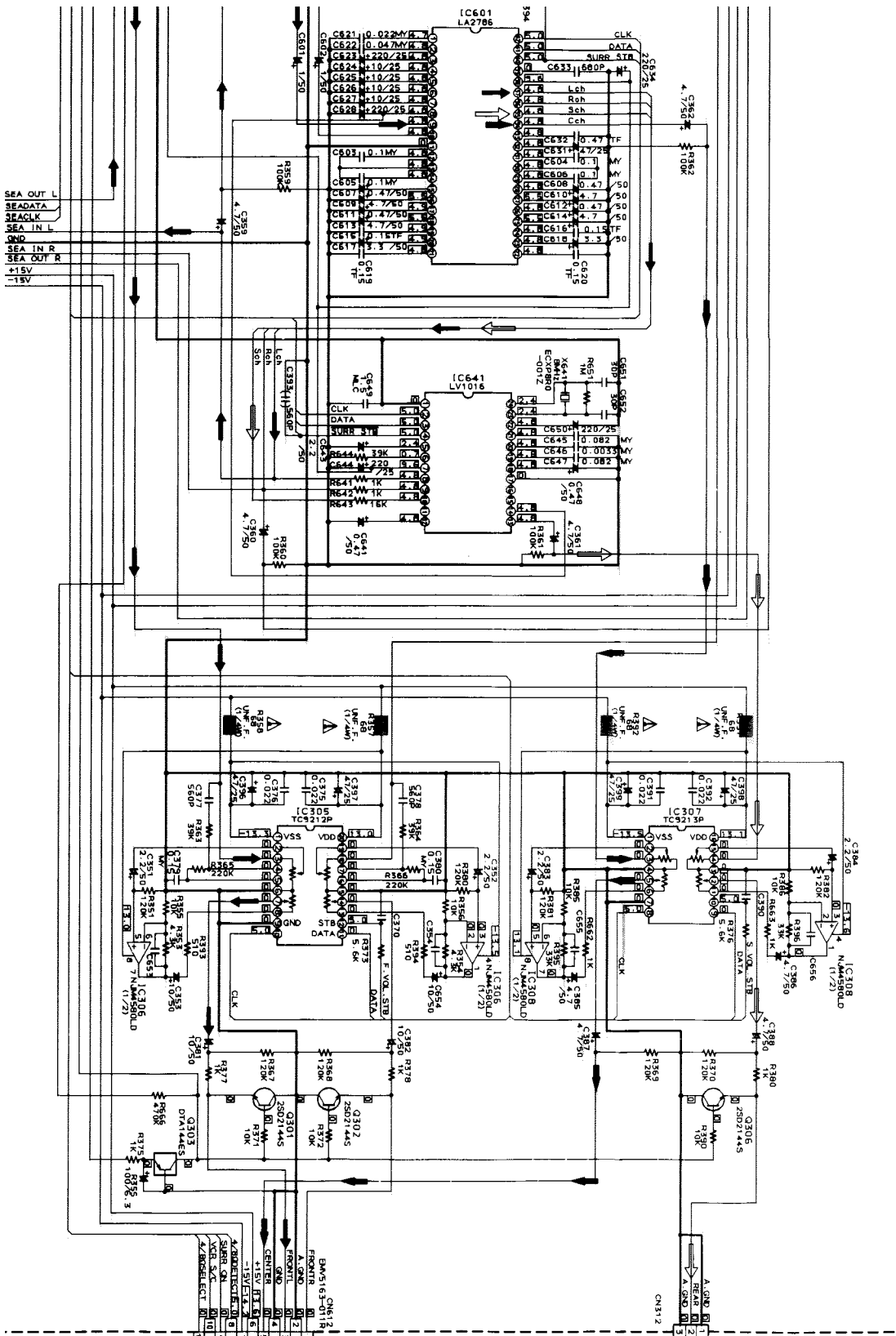

TO CN602 OF ENH-306-1  
SHEET 2/6)

TO CN302 OF ENB-252-4  
SHEET 2/6)

F G H I J



P2-32-a

P2-32-b

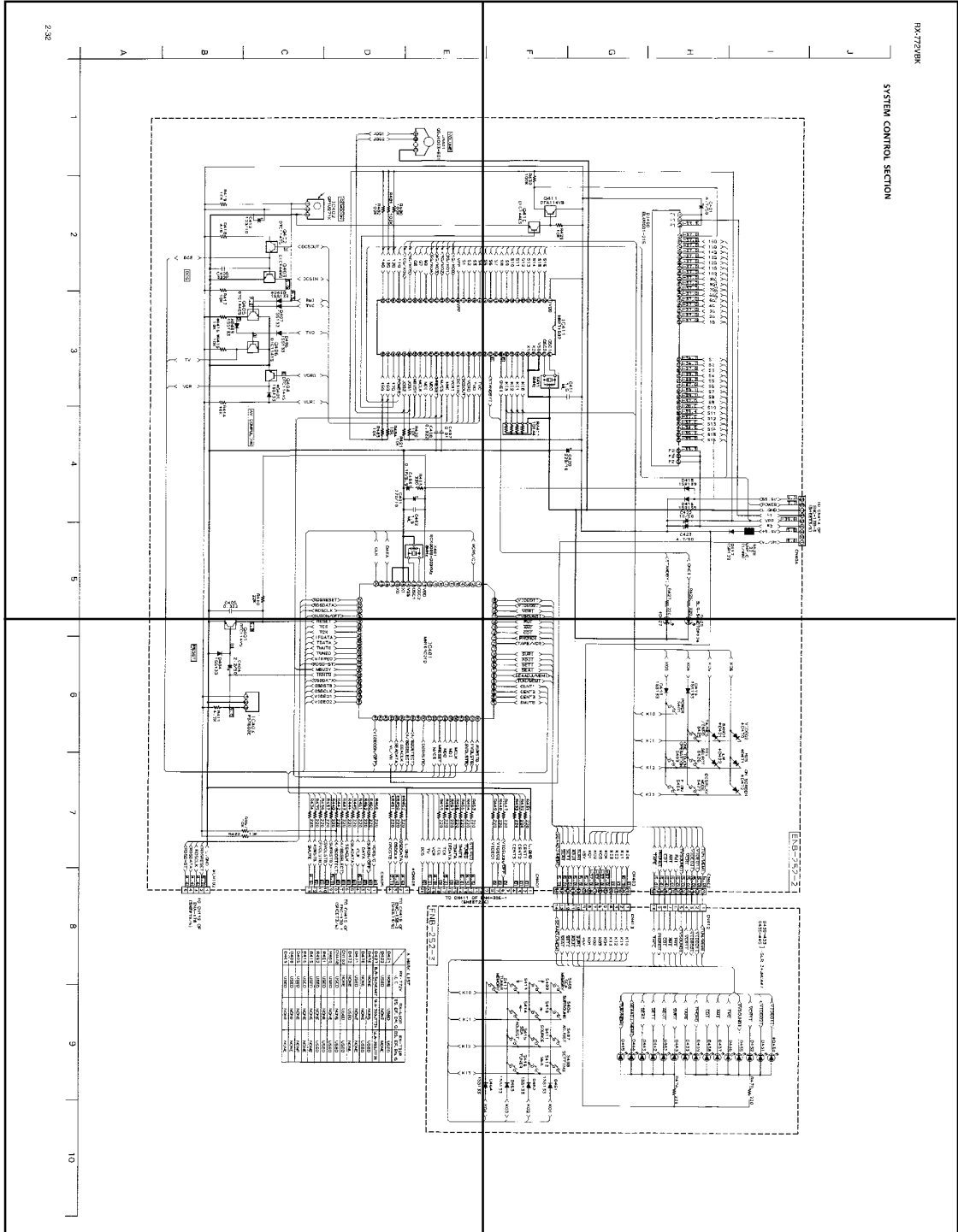

P2-32-c

P2-32-d

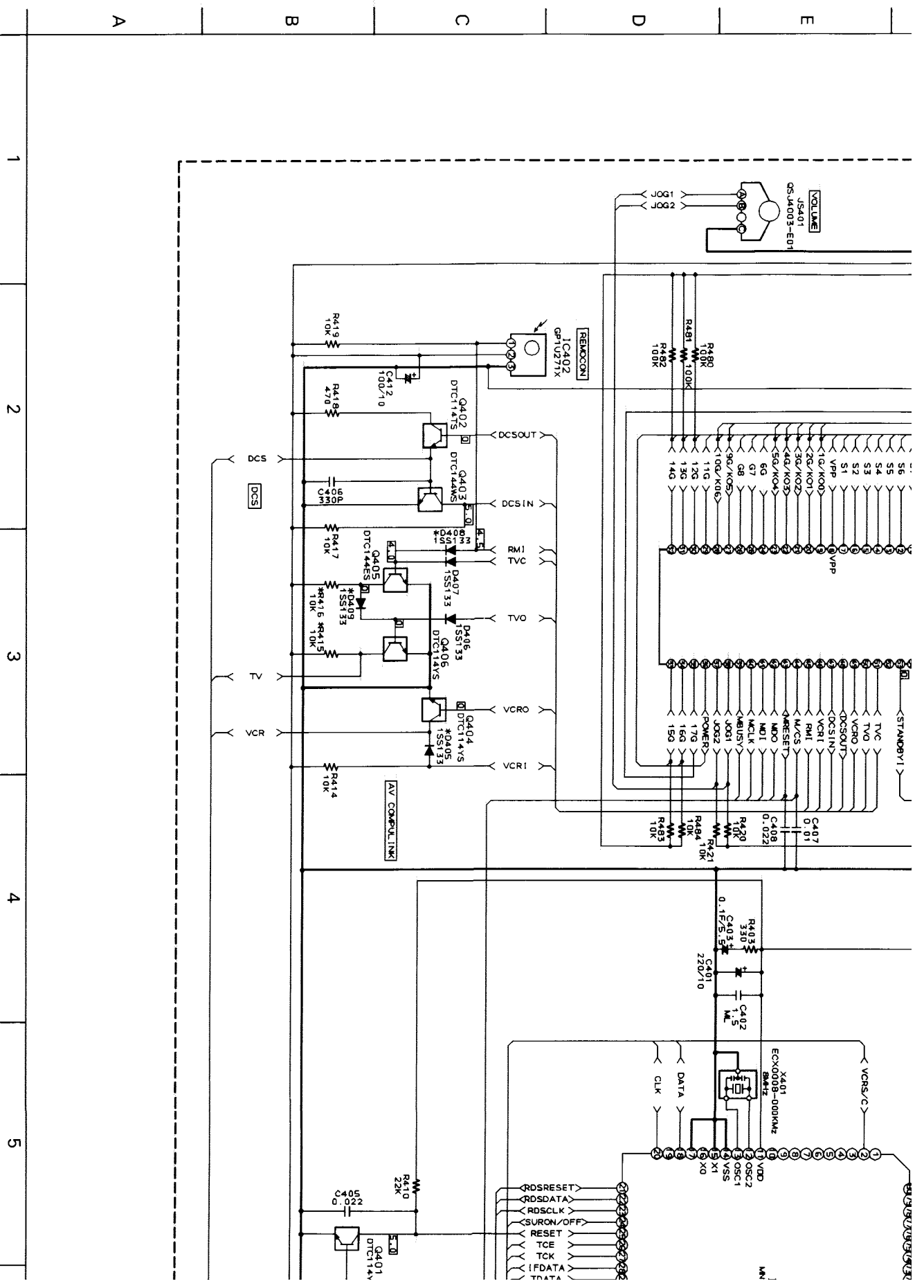

A

B

C

D

E

1

2

3

4

5



SYSTEM CONTROL SECTION

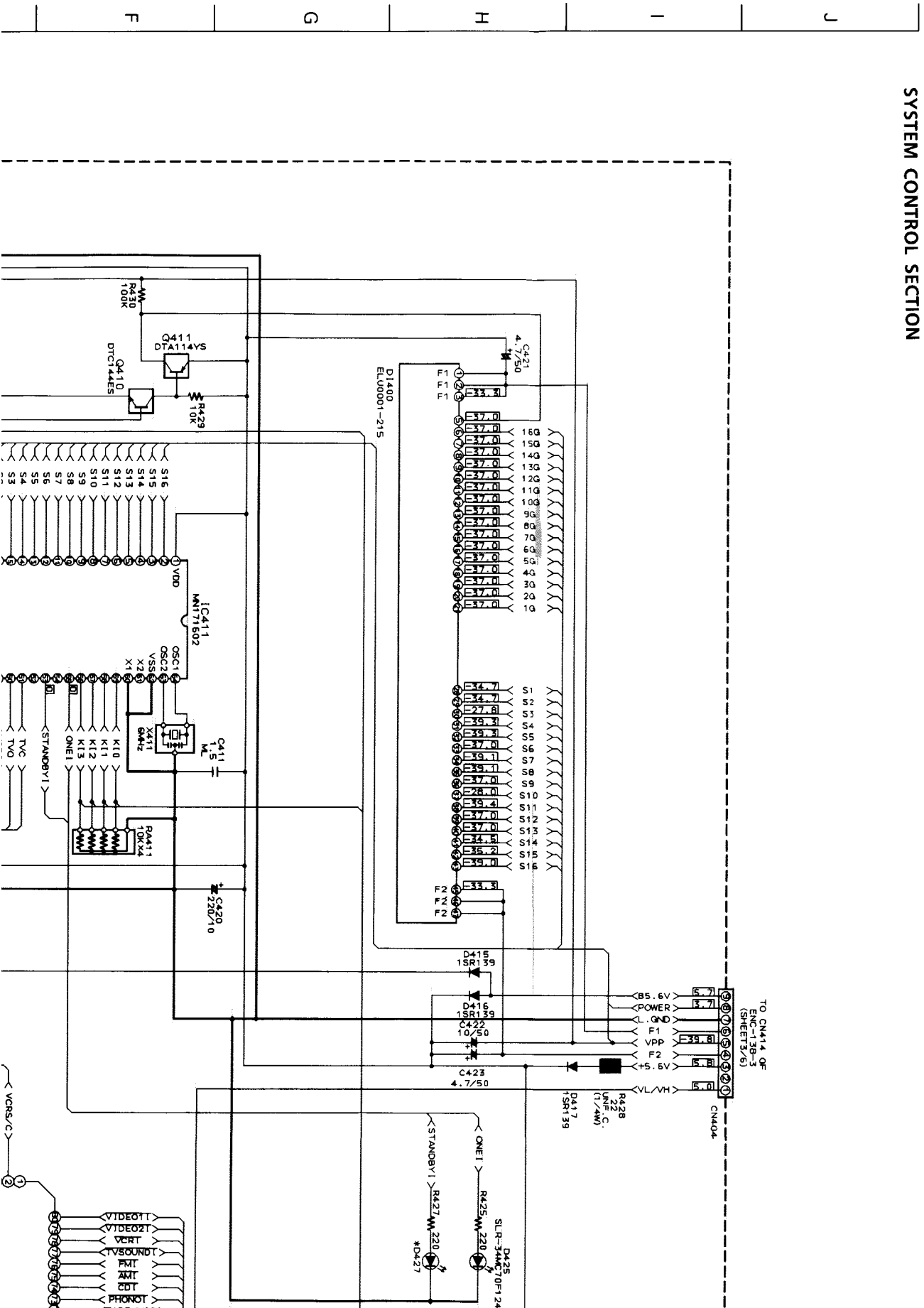

IC401  
M41D1C01D

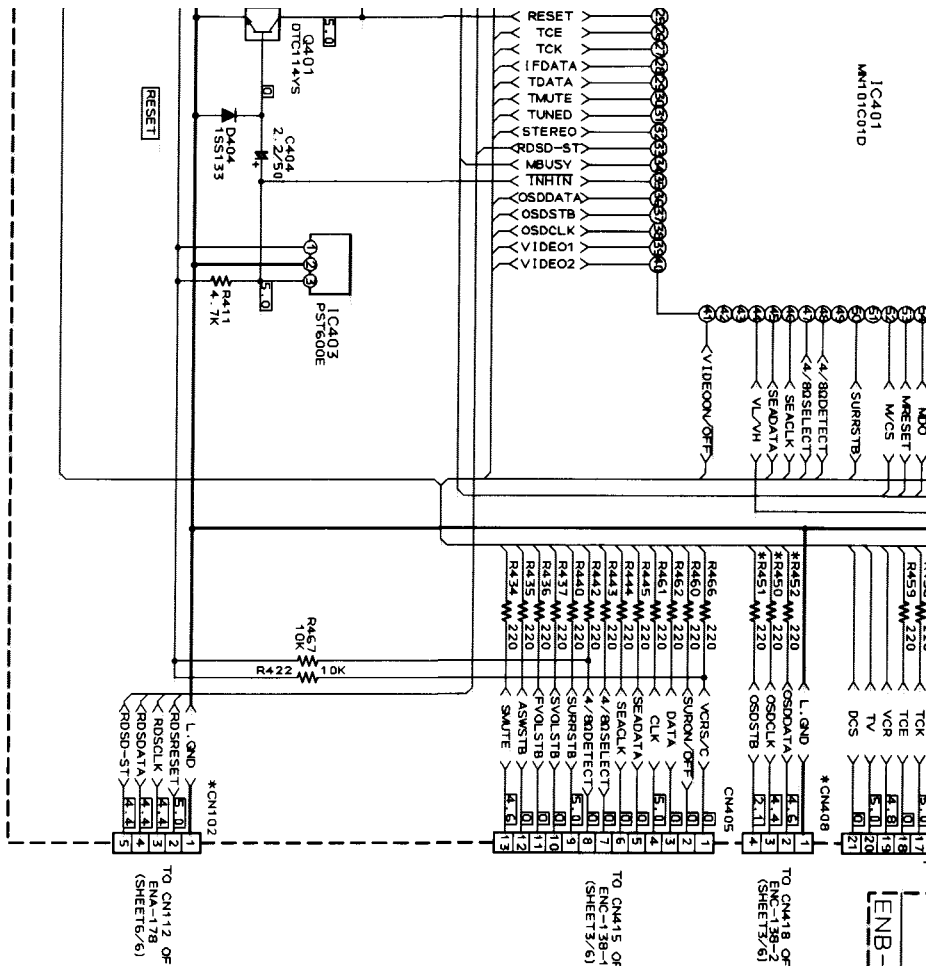

ENB-252-3

\* MARK LIST

MARK	RY-772V U.C	RY-630R BS, EF, EN, G	RY-710R BS, EF, EN, G
D421	NONE	USED	USED
D422	USED	NONE	NONE
D427	SLA-342CA17	SLA-390JT31	SLA-390JT31
D430	NONE	NONE	USED
D470	NONE	NONE	USED
D471	USED	NONE	NONE
D472	NONE	USED	NONE
CN102	NONE	USED	USED
CN408	USED	NONE	USED
R450	USED	NONE	USED
R451	USED	NONE	USED
R452	USED	NONE	USED
R415	USED	NONE	NONE
R416	USED	NONE	NONE
D405	USED	NONE	NONE
D408	USED	NONE	NONE
D409	USED	NONE	NONE

ENB-252-2

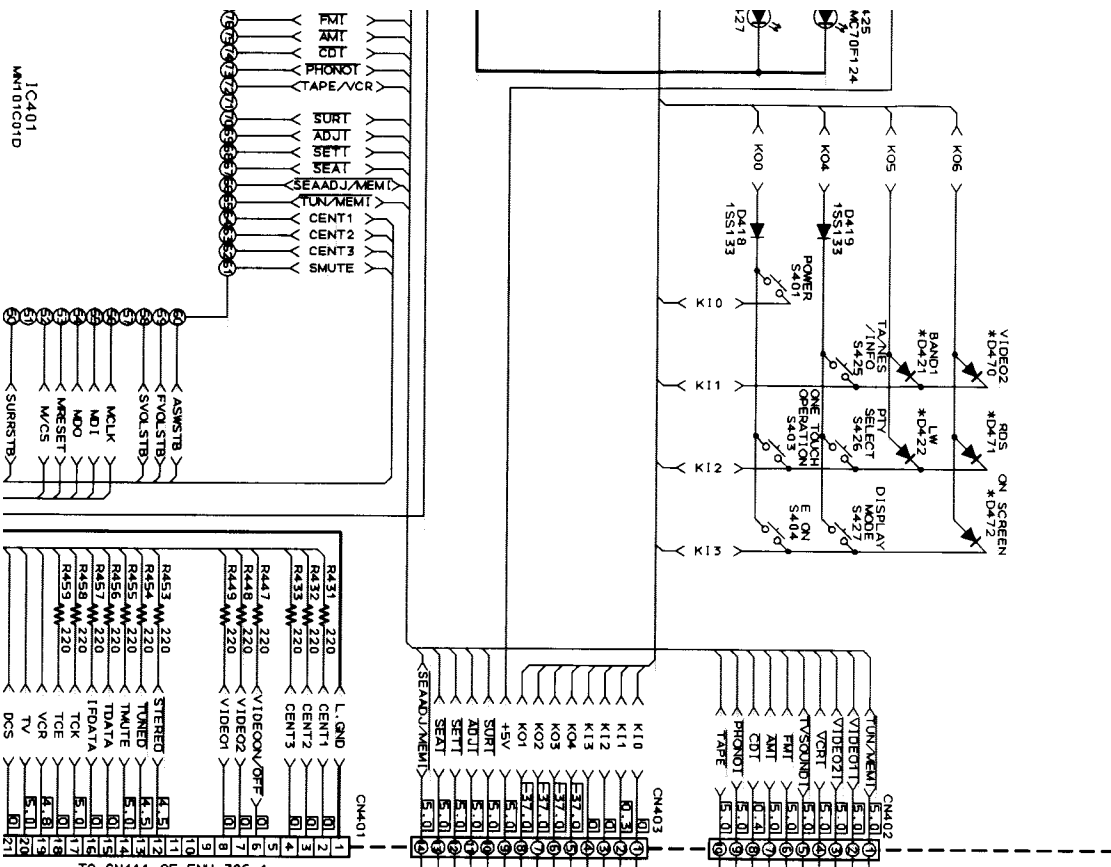

ENB-252-3

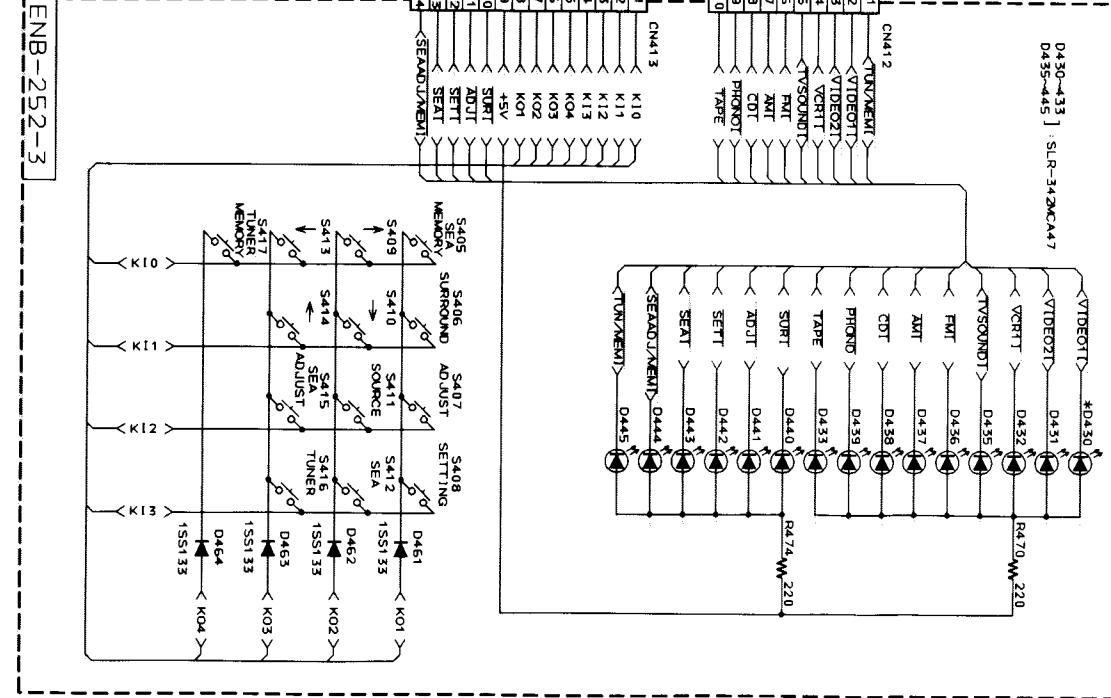



P2-33-a

P2-33-b

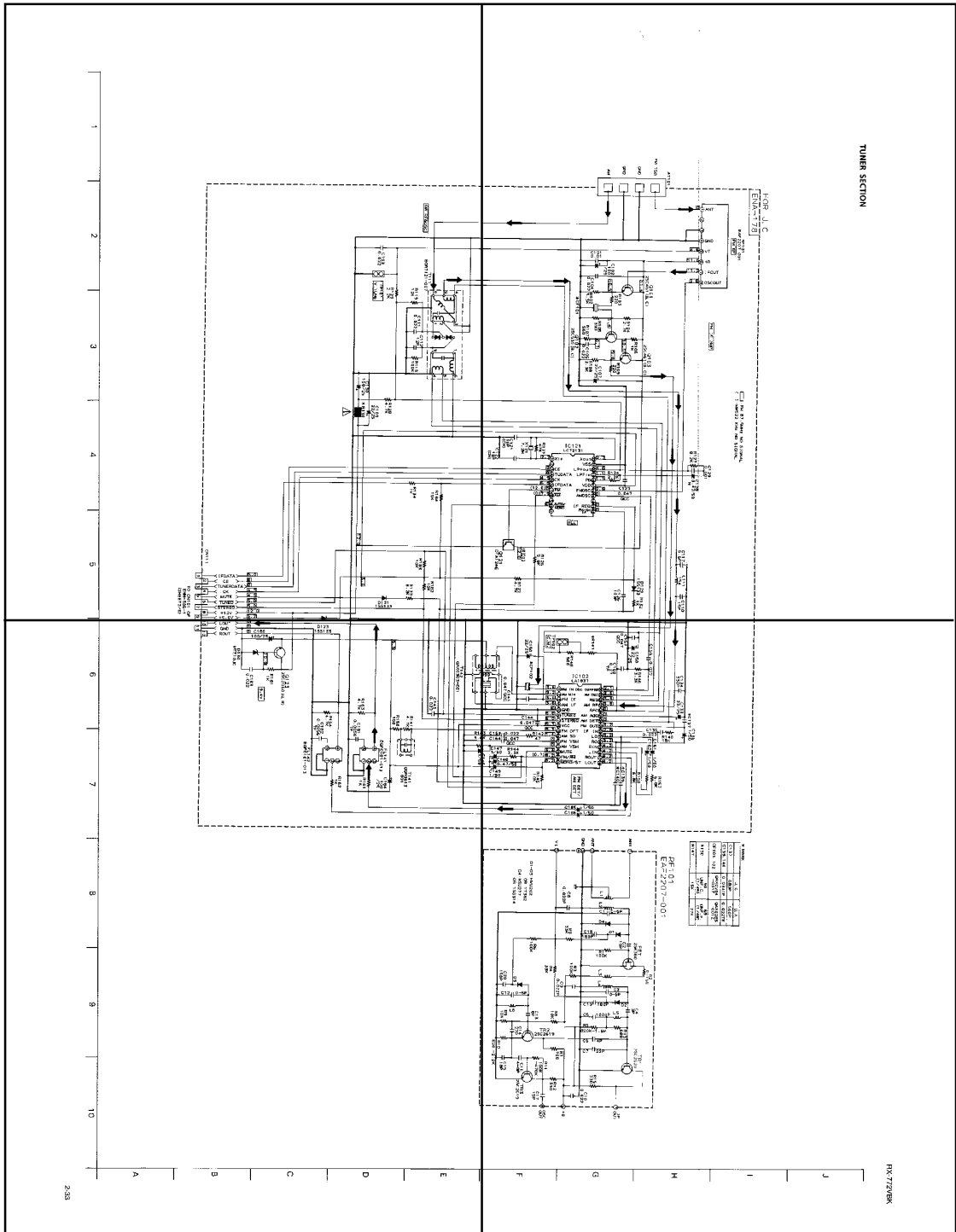

P2-33-c

P2-33-d

1 2 3 4 5

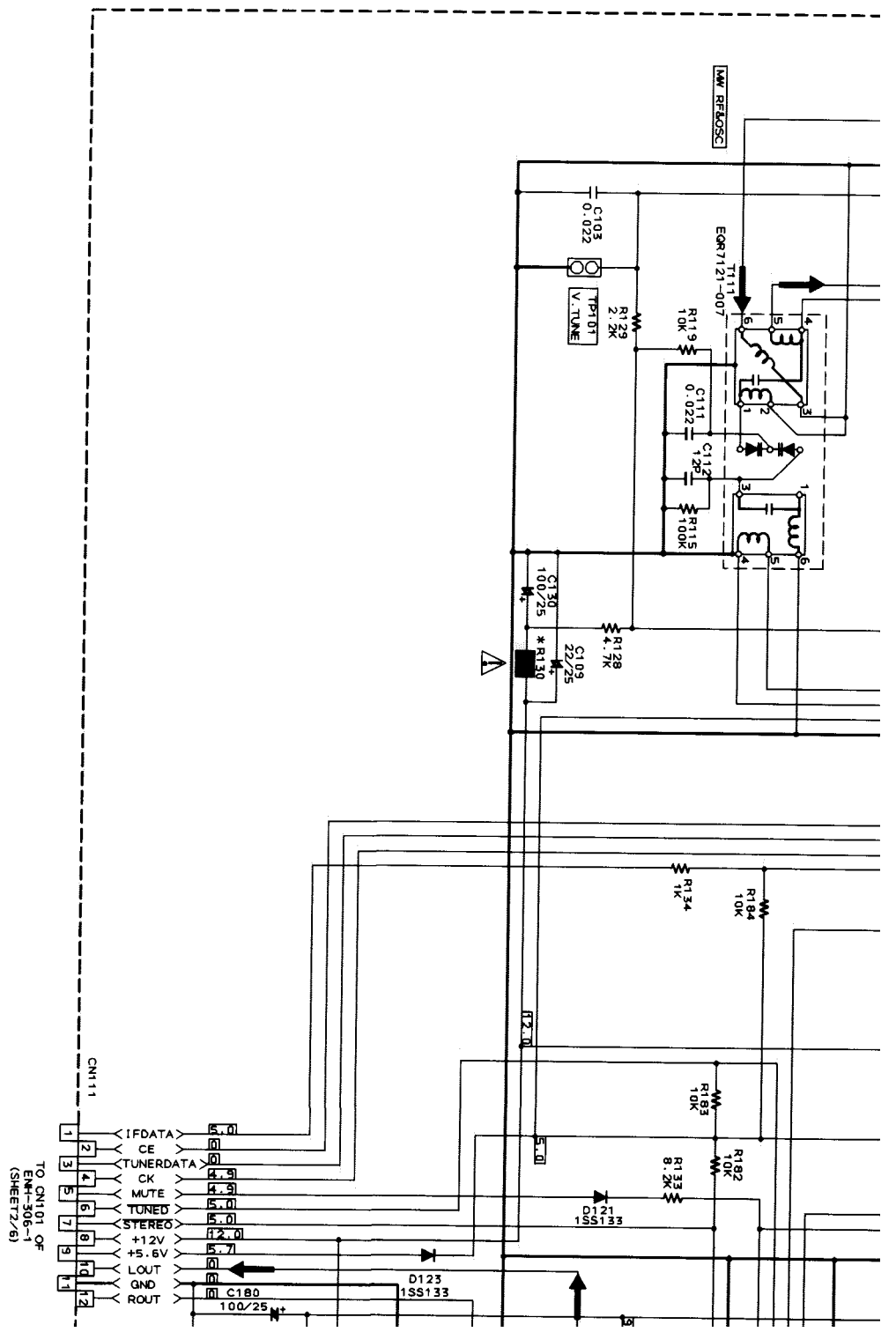

CN111  
 1 IFDATA  
 2 CE  
 3 TUNERDATA  
 4 CK  
 5 MUTE  
 6 TUNED  
 7 STEREO  
 8 +12V  
 9 +5.6V  
 10 LOUT  
 11 GND  
 12 ROUT  
 TO CN101 OF  
 ENH-306-1  
 (SHEET2/6)

TUNER SECTION

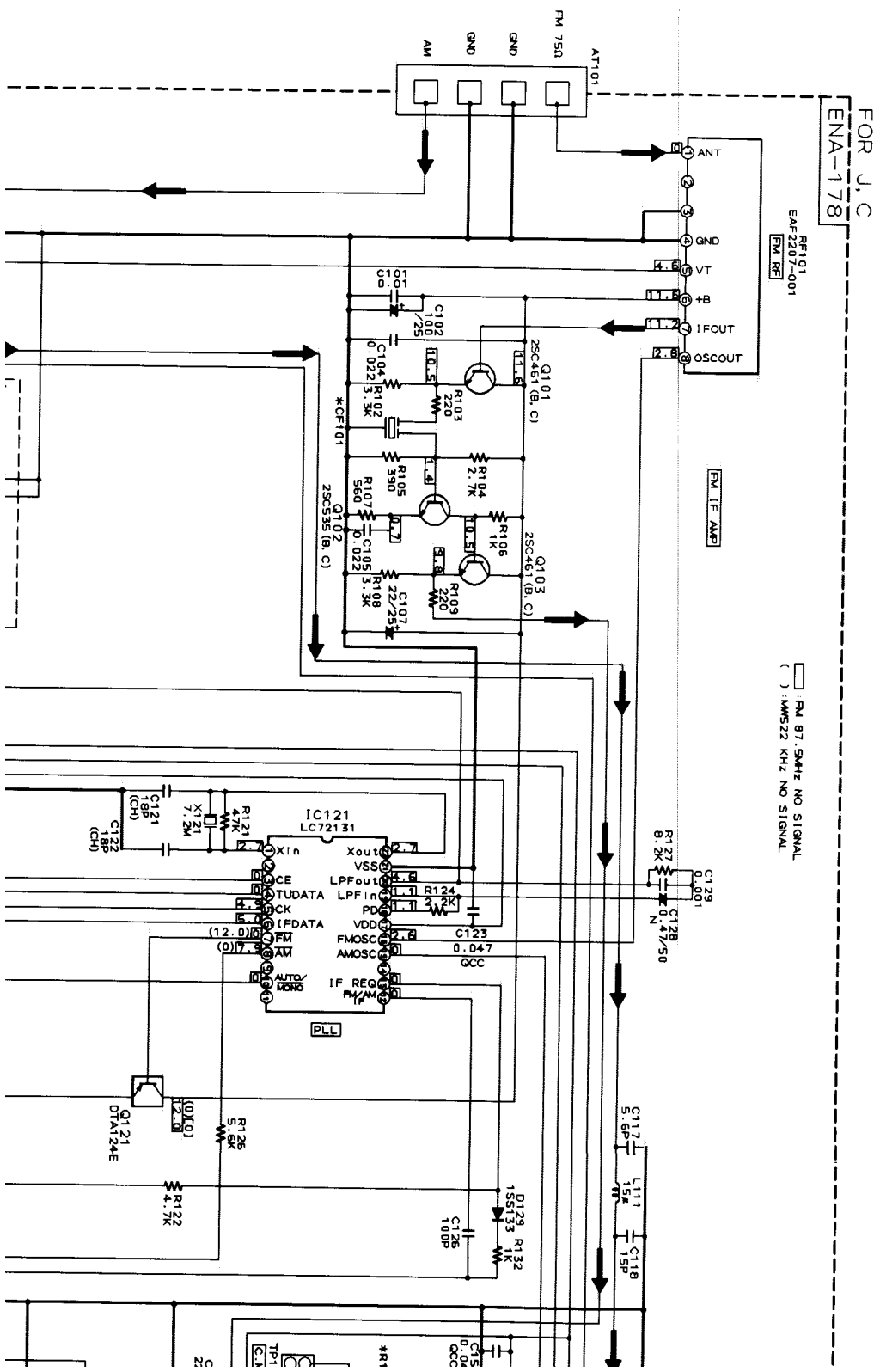

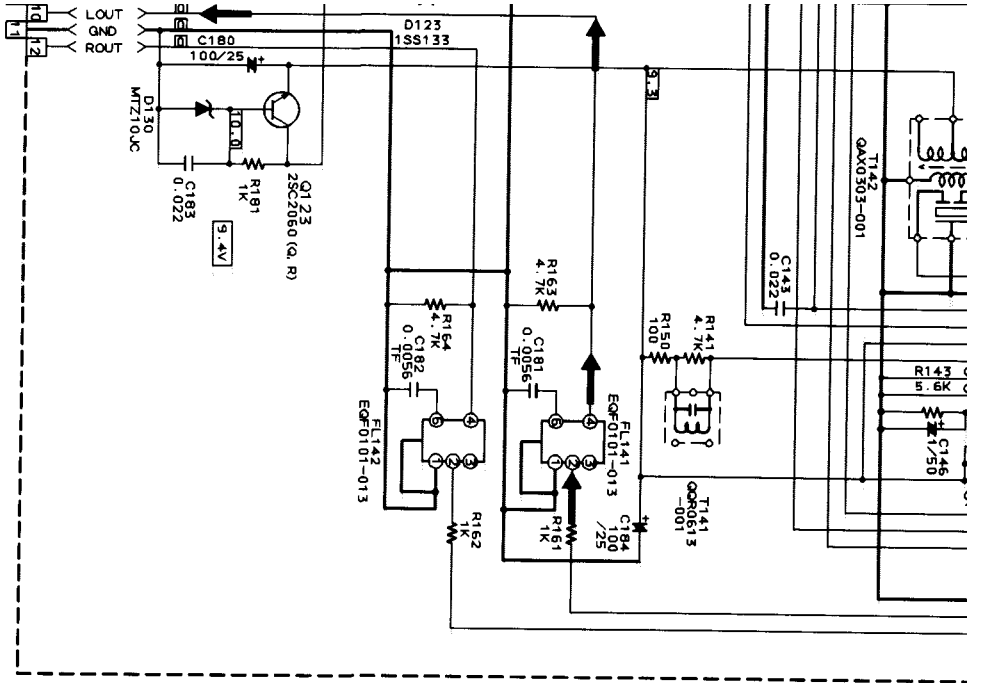

6 7 8 9 10

A B C D E



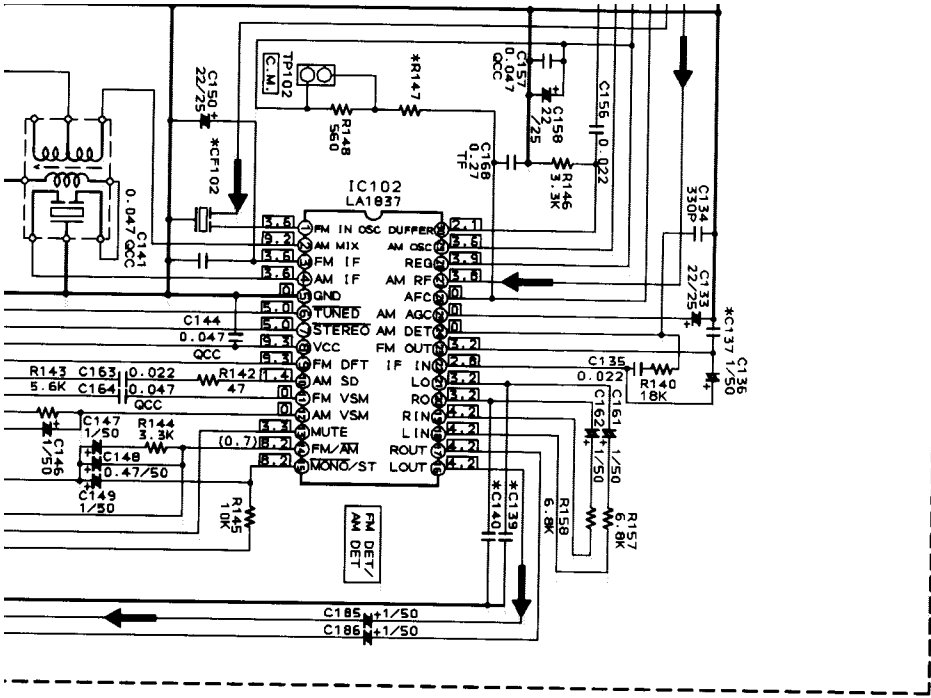

\* MARK

U. C	U. A
C137	680P
C139, 140	0.033TF
CF101, 102	QAX0284 -007Z
R130	68
R147	15K

RF101  
EAF2207-001

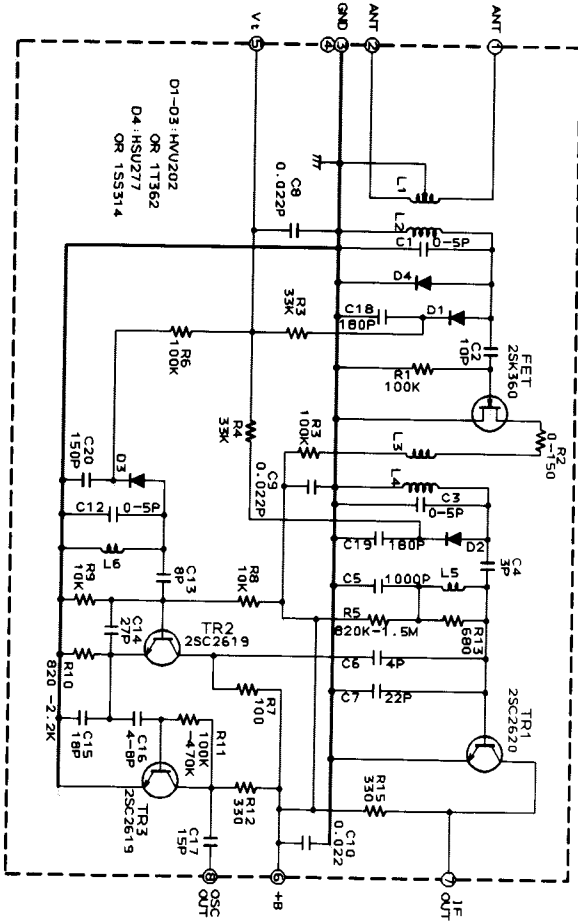



# PARTS LIST

\* All printed circuit boards and its assemblies are not available as service parts.

The Marks for Designated Areas

J --- the U. S. A.

C --- Canada

- Contents -

General Exploded View and Parts List -----	3-2
Electrical Parts List -----	3-4
(ENA-178) -----	3-4
(ENH-306) -----	3-4
(ENB-252) -----	3-7
(ENC-138) -----	3-9
Accessories List -----	3-12
Packing Materials and Part Numbers -----	3-13

## ■ Parts List

Block No. M 1 M M

△	Item	Parts Number	Parts Name	Q'ty	Description	Area
	1	EFP-RX772VBKJ(S)	FRONT PANEL ASSY	1		
	1-1	LE10082-005A	FRONT PANEL	1		
	1-2	LE30374-003A	WINDOW SCREEN	1		
	1-3	VJD5429-001	JVC MARK	1		
	2	LE20133-002A	PUSH BUTTON	1		
	3	LE30367-001A	PUSH BUTTON	1		
	4	LE30369-003A	PUSH BUTTON	1		
	5	LE40148-001A	INDICATOR LENS	1		
	6	LE30372-001A	INDICATOR LENS	2		
	7	LE30373-001A	INDICATOR LENS	2		
	8	SDSF2608Z	SCREW	9		
	9	VWF1221-32TTBV	FLAT WIRE	1		
	10	VWF1213-32TTBV	FLAT WIRE	1		
	11	SDSG3008M	TAPPING SCREW	4		
	12	SBSG3008CC	TAPPING SCREW	27		
	13	E102820-004SM	BOTTOM PLATE	1		
	14	E70115-002	CAUTION LABEL	1		C
		E70281-001	CAUTION LABEL	1		J
	15	E208081-003SM	SIDE BRACKET	1		
	16	E208548-001SM	SIDE BRACKET	1		
	17	E208549-001SM	CENTER BRACKET	1		
	18	E68587-010	BRACKET	1		
	19	E407984-001SM	P. W. BOARD HOLDER	1		
	20	VJF4039-00P	FOOT ASSY	2		
	21	E47227-036	FOOT	2		
	22	SBST3010Z	TAPPING SCREW	4		
	23	LE10084-002A	FRONT BRACKET	1		
	24	LE40139-001A	HEADPHONE BRACKET	1		
	25	VKZ4150-001	NUT	1		
	26	E407321-002SM	PUSH BUTTON	2		
	27	LE30377-001A	PUSH SHAFT	2		
	28	LE30376-001A	TRANSFORMER BRACKET	1		
	29	E65389-006	SPECIAL SCREW	8		
	30	E310244-003	FASTENER	1		
	31	E308835-008SM	HEAT SINK	1		
	32	E308836-003SM	HEAT SINK BRACKET	1		
	33	E308836-004SM	HEAT SINK BRACKET	1		
	34	E73525-003	SCREW	8		
	35	2SD2155LB(R, 0)	SI. TRANSISTOR	2	Q731. Q732	
	36	2SB1429LB(R, 0)	SI. TRANSISTOR	2	Q733. Q734	
	37	2SC4468/P/-F1	TR.	2	Q016. Q056	
	38	2SA1695/P/-F1	TR.	2	Q013. Q058	
△	39	QQT0172-001	POWER TRANSFORMER	1		
	40	LE10085-009A	REAR PANEL	1		
	41	E73273-003	SPECIAL SCREW	22		
	42	E409257-001	EARTH TERMINAL	1		
△	43	QMP1D00-200H	POWER CORD	1		
△	44	QHS3771-108	CORD STOPPER	1		
	45	E306805-146	SPACER	3		
	46	LE20132-001A(S)	METAL COVER	1		
	47	E61660-004	SPECIAL SCREW	4		
	48	E309823-001SM	VOLUME KNOB	1		
△	49	QMF0007-6R3J1	FUSE	1	F001	
△	50	QMF0007-2R0J1	FUSE	2	F851. F852	
	51	E65507-001	CAUTION LABEL	1		C
		E67199-001	CAUTION LABEL	2		J
	52	GBSG3008CC	TAPPING SCREW	14		
	-	E409394-001	CAUTION LABEL	1		J
	-	E409396-001	CAUTION LABEL	1		C



General Exploded View and Parts List

Block No, M 1 M M

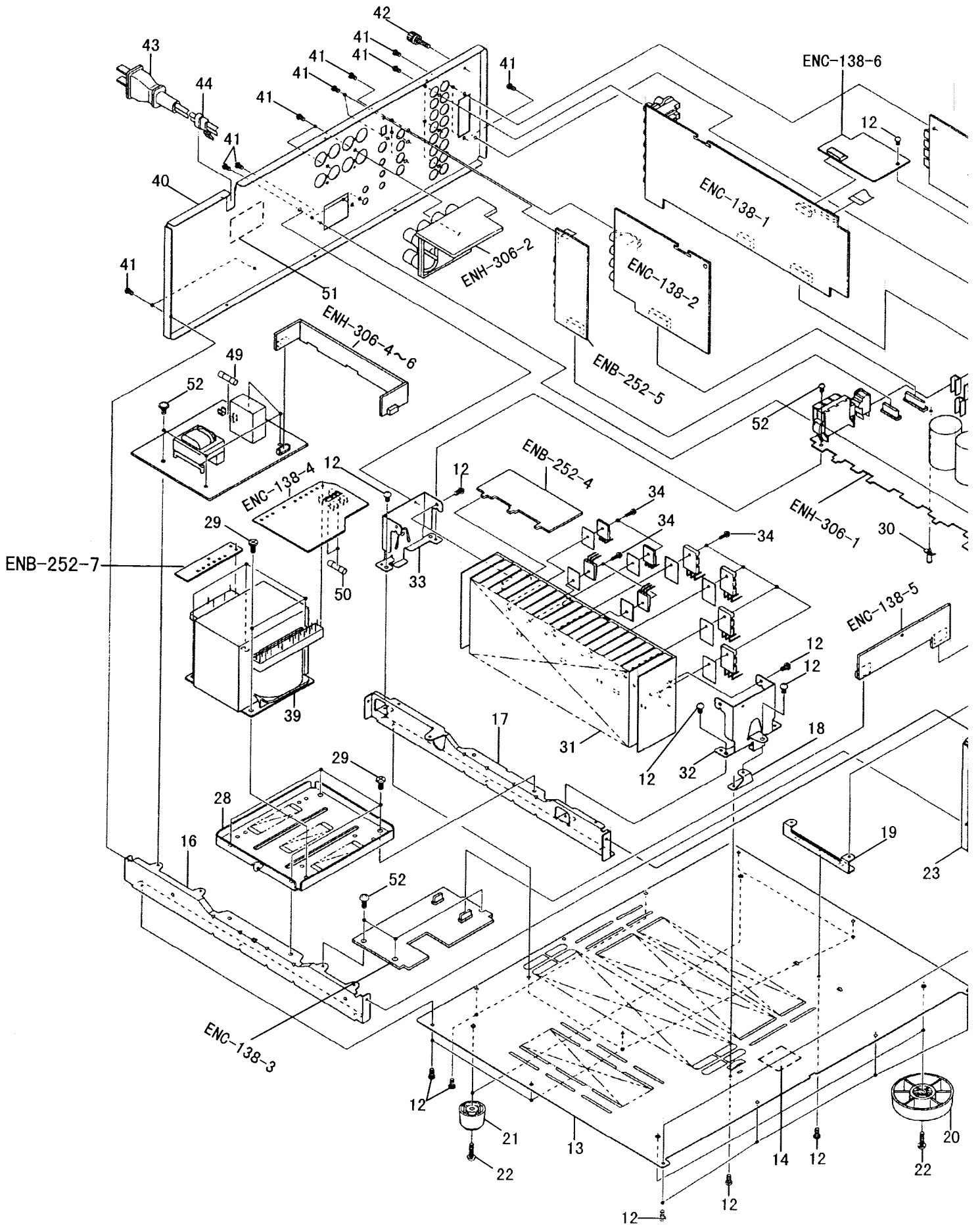

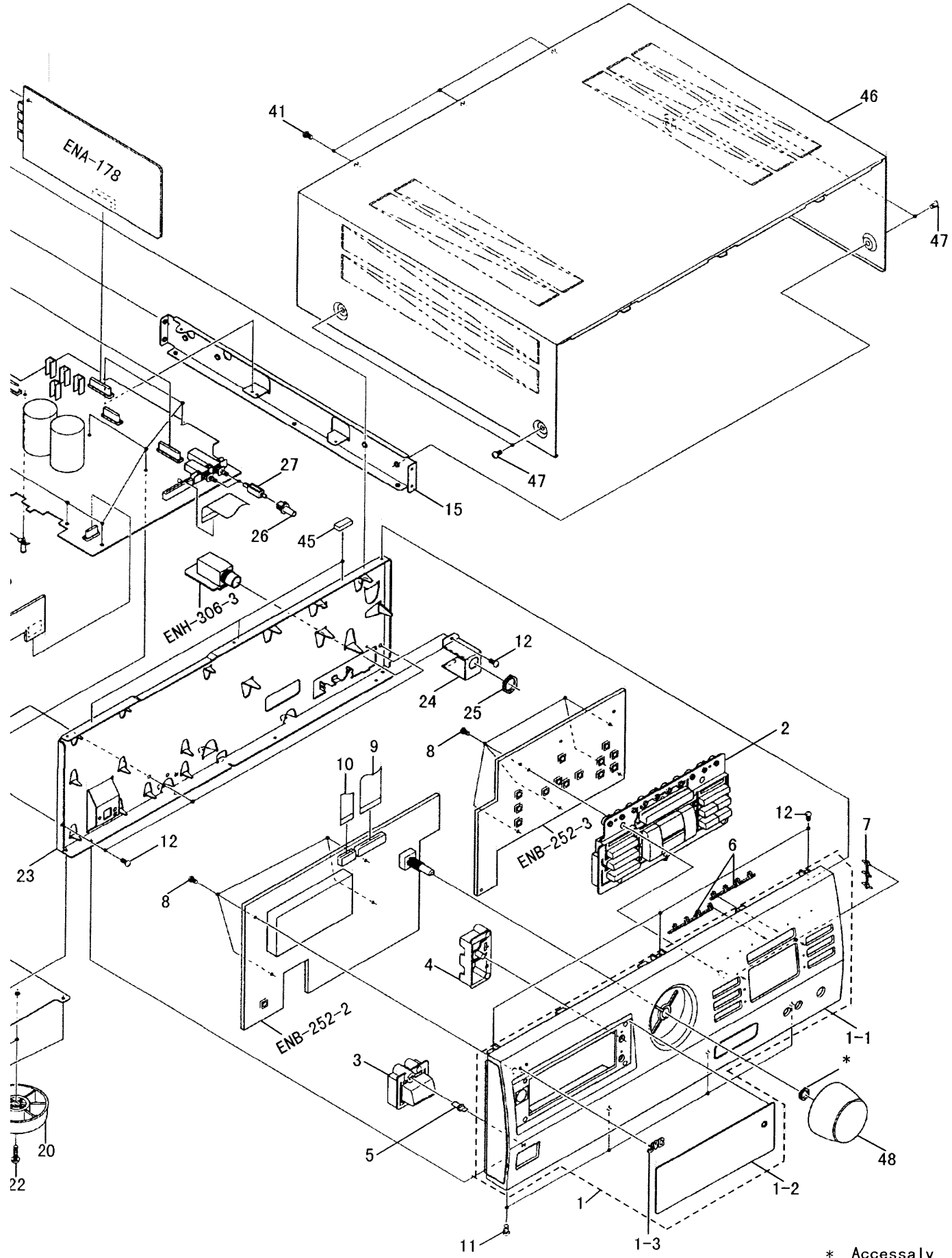

\* Accessory

■ Electrical Parts List (ENA-178)

△	Item	Parts Number	Description	Area
		I. C. S		
	IC102	LA1837	I. C (MONO-ANALOG)	
	IC121	LC72131	I. C (M)	
		DIODES		
	D121	1SS133	SI. DIODE	
	D123	1SS133	SI. DIODE	
	D129	1SS133	SI. DIODE	
	D130	MTZ10JC	ZENER DIODE	
		TRANSISTORS		
	Q101	2SC461	SI. TRANSISTOR	
	Q102	2SC535	SI. TRANSISTOR	
	Q103	2SC461	SI. TRANSISTOR	
	Q121	DTA124ES	DIGITAL TRANSISTOR	
	Q123	2SC2060 (Q. R)	SI. TRANSISTOR	
		CAPACITORS		
	C101	QCVB1CM-103Y	0.01MF 16V CER. CAP.	
	C102	QETN1EM-107Z	100MF 25V E. CAP.	
	C103	QCHB1EZ-223	0.022MF 25V CER. CAP.	
	C104	QCHB1EZ-223	0.022MF 25V CER. CAP.	
	C105	QCHB1EZ-223	0.022MF 25V CER. CAP.	
	C107	QETN1EM-226Z	22MF 25V E. CAP.	
	C109	QETN1EM-226Z	22MF 25V E. CAP.	
	C111	QCHB1EZ-223	0.022MF 25V CER. CAP.	
	C112	QCT30CH-120Y	12PF 50V CER. CAP.	
	C117	QCSB1HK-5R6Y	5.6PF 50V CER. CAP.	
	C118	QCSB1HJ-150Y	15PF 50V CER. CAP.	
	C121	QCT30CH-180Y	18PF 50V CER. CAP.	
	C122	QCT30CH-180Y	18PF 50V CER. CAP.	
	C123	QCC21EM-473	0.047MF 25V CER. CAP.	
	C126	QCB1HK-101Y	100PF 50V CER. CAP.	
	C128	QENB1HM-474	0.47MF 50V NP E. CAP.	
	C129	QGB1HK-102	1000PF 50V CER. CAP.	
	C130	QETN1EM-107Z	100MF 25V E. CAP.	
	C133	QETN1EM-226Z	22MF 25V E. CAP.	
	C134	QCB1HK-331Y	330PF 50V CER. CAP.	
	C135	QCHB1EZ-223	0.022MF 25V CER. CAP.	
	C136	QETN1HM-105Z	1MF 50V AL E. CAP.	
	C137	QCB1HK-681Y	680PF 50V CER. CAP.	
	C139	QFLB1HJ-333	0.033MF 50V MYLAR CAP.	
	C140	QFLB1HJ-333	0.033MF 50V MYLAR CAP.	
	C141	QCC21EM-473	0.047MF 25V CER. CAP.	
	C143	QCHB1EZ-223	0.022MF 25V CER. CAP.	
	C144	QCC21EM-473	0.047MF 25V CER. CAP.	
	C146	QETN1HM-105Z	1MF 50V AL E. CAP.	
	C147	QETN1HM-105Z	1MF 50V AL E. CAP.	
	C148	QETN1HM-474Z	0.47MF 50V AL E. CAP.	
	C149	QETN1HM-105Z	1MF 50V AL E. CAP.	
	C150	QETN1EM-226Z	22MF 25V E. CAP.	
	C156	QCHB1EZ-223	0.022MF 25V CER. CAP.	
	C157	QCC21EM-473	0.047MF 25V CER. CAP.	
	C158	QETN1EM-226Z	22MF 25V E. CAP.	
	C161	QETN1HM-105Z	1MF 50V AL E. CAP.	
	C162	QETN1HM-105Z	1MF 50V AL E. CAP.	
	C163	QCHB1EZ-223	0.022MF 25V CER. CAP.	
	C164	QCC21EM-473	0.047MF 25V CER. CAP.	
	C168	QFV81HJ-274	0.27MF 50V THIN FILM CAP.	
	C180	QETN1EM-107Z	100MF 25V E. CAP.	
	C181	QFLB1HJ-562	5600PF 50V MYLAR CAP.	
	C182	QFLB1HJ-562	5600PF 50V MYLAR CAP.	
	C183	QCHB1EZ-223	0.022MF 25V CER. CAP.	
	C184	QETN1EM-107Z	100MF 25V E. CAP.	
	C185	QETN1HM-105Z	1MF 50V AL E. CAP.	
	C186	QETN1HM-105Z	1MF 50V AL E. CAP.	
		RESISTORS		
	R102	QRD167J-332	3.3K 1/6W CARBON RES.	
	R103	QRD161J-221	220 1/6W CARBON RES.	
	R104	QRD167J-272	2.7K 1/6W CARBON RES.	
	R105	QRD161J-391	390 1/6W CARBON RES.	

△	Item	Parts Number	Description	Area
	R106	QRD161J-102	1K 1/6W CARBON RES.	
	R107	QRD161J-561	560 1/6W CARBON RES.	
	R108	QRD167J-332	3.3K 1/6W CARBON RES.	
	R109	QRD161J-221	220 1/6W CARBON RES.	
	R115	QRD161J-104	100K 1/6W CARBON RES.	
	R119	QRD161J-103	10K 1/6W CARBON RES.	
	R121	QRD161J-473	47K 1/6W CARBON RES.	
	R122	QRD161J-472	4.7K 1/6W CARBON RES.	
	R124	QRD161J-222	2.2K 1/6W CARBON RES.	
	R126	QRD167J-562	5.6K 1/6W CARBON RES.	
	R127	QRD167J-822	8.2K 1/6W CARBON RES.	
	R128	QRD161J-472	4.7K 1/6W CARBON RES.	
	R129	QRD161J-222	2.2K 1/6W CARBON RES.	
△	R130	QRD140J-680SX	68 1/4W UNF. CARBON R	
	R132	QRD161J-102	1K 1/6W CARBON RES.	
	R133	QRD167J-822	8.2K 1/6W CARBON RES.	
	R134	QRD161J-102	1K 1/6W CARBON RES.	
	R140	QRD161J-183	18K 1/6W CARBON RES.	
	R141	QRD161J-472	4.7K 1/6W CARBON RES.	
	R142	QRD161J-470	47 1/6W CARBON RES.	
	R143	QRD167J-562	5.6K 1/6W CARBON RES.	
	R144	QRD167J-332	3.3K 1/6W CARBON RES.	
	R145	QRD161J-103	10K 1/6W CARBON RES.	
	R146	QRD167J-332	3.3K 1/6W CARBON RES.	
	R147	QRD167J-153	15K 1/6W CARBON RES.	
	R148	QRD161J-561	560 1/6W CARBON RES.	
	R150	QRD161J-101	100 1/6W CARBON RES.	
	R157	QRD167J-682	6.8K 1/6W CARBON RES.	
	R158	QRD167J-682	6.8K 1/6W CARBON RES.	
	R161	QRD161J-102	1K 1/6W CARBON RES.	
	R162	QRD161J-102	1K 1/6W CARBON RES.	
	R163	QRD161J-472	4.7K 1/6W CARBON RES.	
	R164	QRD161J-472	4.7K 1/6W CARBON RES.	
	R181	QRD161J-102	1K 1/6W CARBON RES.	
	R182	QRD161J-103	10K 1/6W CARBON RES.	
	R183	QRD161J-103	10K 1/6W CARBON RES.	
	R184	QRD161J-103	10K 1/6W CARBON RES.	
		OTHERS		
		EMW10684-003A	PRINTED BOARD	
	L111	EQL4007-1501	INDUCTOR	
	T111	EQR7121-007	RF COIL	
	T141	QOR0613-001	I. F. TRANSFORMER	
	T142	GAX0303-001	CERAMIC FILTER	
	X121	EGX0007-200KWJ1	CRYSTAL	
	AT101	FMMB10YV-401K	ANTENNA TERMINAL	
	CF101	GAX0284-001Z	CERAMIC FILTER	
	CF102	GAX0284-001Z	CERAMIC FILTER	
	CN111	EMV5163-012R	CONNECT TERMINAL	
	FL141	EQF0101-013	LOWPASS FILTER	
	FL142	EQF0101-013	LOWPASS FILTER	
	RF101	EAF2207-001	FRONT END	



## ■ Electrical Parts List (ENH-306)

△	Item	Parts Number	Description	Area
		I. C. S		
	IC501	BU4051BC	I. C (DIGI-MOS)	
	IC511	BA15218N	I. C (MONO-ANALOG)	
	IC901	TA7317P	I. C (MONO-ANALOG)	
		DIODES		
	D010	1SS133	SI. DIODE	
	D011	MTZ18JC	ZENER DIODE	
	D012	1SS133	SI. DIODE	
	D013	1SS133	SI. DIODE	
	D014	1SS133	SI. DIODE	
	D015	1SS133	SI. DIODE	
	D021	1SS133	SI. DIODE	
	D022	1SS133	SI. DIODE	
	D482	1SS133	SI. DIODE	
	D483	1SS133	SI. DIODE	
	D484	MTZ6.2JC	ZENER DIODE	
	D520	MTZ5.1JC	ZENER DIODE	
	D521	MTZ5.1JC	ZENER DIODE	
	D701	1SS133	SI. DIODE	
	D702	1SS133	SI. DIODE	
	D703	1SS133	SI. DIODE	
	D704	1SS133	SI. DIODE	
	D705	MTZ18JC	ZENER DIODE	
	D709	1SS133	SI. DIODE	
	D710	1SS133	SI. DIODE	
	D711	1SS133	SI. DIODE	
	D712	1SS133	SI. DIODE	
	D713	MTZ10JC	ZENER DIODE	
	D714	MTZ12JC	ZENER DIODE	
	D811	1SS133	SI. DIODE	
	D812	MTZ15JC	ZENER DIODE	
	D813	1SS133	SI. DIODE	
	D814	MTZ6.8JC	ZENER DIODE	
	D815	1SS133	SI. DIODE	
	D816	MTZ15JC	ZENER DIODE	
	D817	1SS133	SI. DIODE	
	D818	1SS133	SI. DIODE	
	D819	MTZ13JC	ZENER DIODE	
	D820	MTZ5.1JC	ZENER DIODE	
	D821	MTZ10JC	ZENER DIODE	
	D901	1SS133	SI. DIODE	
	D902	1SS133	SI. DIODE	
	D903	1SS133	SI. DIODE	
		TRANSISTORS		
	Q011	2SC2240 (GR. BL)	SI. TRANSISTOR	
	Q012	2SC2240 (GR. BL)	SI. TRANSISTOR	
	Q013	2SA1038 (R. S)	SI. TRANSISTOR	
	Q015	2SC2235 (O. Y)	SI. TRANSISTOR	
	Q017	2SA965 (Y)	SI. TRANSISTOR	
	Q019	2SC1775AV (F1)	SI. TRANSISTOR	
	Q020	DIC123YS	DIGITAL TRANSISTOR	
	Q021	2SC2389 (S. E)	SI. TRANSISTOR	
	Q022	2SA1038 (R. S)	SI. TRANSISTOR	
	Q701	2SC1775AV (F1)	SI. TRANSISTOR	
	Q702	2SC1775AV (F1)	SI. TRANSISTOR	
	Q703	2SC1775AV (F1)	SI. TRANSISTOR	
	Q704	2SC1775AV (F1)	SI. TRANSISTOR	
	Q705	2SA1038 (R. S)	SI. TRANSISTOR	
	Q706	2SA1038 (R. S)	SI. TRANSISTOR	
	Q707	2SA933LN (R. S)	SI. TRANSISTOR	
	Q708	2SA933LN (R. S)	SI. TRANSISTOR	
	Q709	2SA1038 (R. S)	SI. TRANSISTOR	
	Q710	2SA1038 (R. S)	SI. TRANSISTOR	
	Q711	2SC2389 (S. E)	SI. TRANSISTOR	
	Q712	2SC2389 (S. E)	SI. TRANSISTOR	
	Q717	2SC2389 (S. E)	SI. TRANSISTOR	
	Q718	2SC2389 (S. E)	SI. TRANSISTOR	
	Q719	2SA1038 (R. S)	SI. TRANSISTOR	

△	Item	Parts Number	Description	Area
	Q720	2SA1038 (R. S)	SI. TRANSISTOR	
	Q721	2SD636	SI. TRANSISTOR	
	Q722	2SD636	SI. TRANSISTOR	
	Q723	2SC2389 (S. E)	SI. TRANSISTOR	
	Q724	2SC2389 (S. E)	SI. TRANSISTOR	
	Q725	2SA1038 (R. S)	SI. TRANSISTOR	
	Q726	2SA1038 (R. S)	SI. TRANSISTOR	
	Q727	2SC2235 (O. Y)	SI. TRANSISTOR	
	Q728	2SC2235 (O. Y)	SI. TRANSISTOR	
	Q729	2SA965 (Y)	SI. TRANSISTOR	
	Q730	2SA965 (Y)	SI. TRANSISTOR	
	Q735	2SD2061 (F. G)	SI. TRANSISTOR	
	Q736	2SC2240 (GR. BL)	SI. TRANSISTOR	
	Q801	2SB1187 (F. G)	SI. TRANSISTOR	
	Q803	2SD2061 (F. G)	SI. TRANSISTOR	
	Q804	2SD2061 (F. G)	SI. TRANSISTOR	
	Q805	2SD2061 (F. G)	SI. TRANSISTOR	
	Q806	2SC2235 (O. Y)	SI. TRANSISTOR	
	Q901	2SC2389 (S. E)	SI. TRANSISTOR	
	Q902	2SC2389 (S. E)	SI. TRANSISTOR	
	Q903	2SA1038 (R. S)	SI. TRANSISTOR	
	Q904	2SK301 (P. Q)	F. E. T.	
	Q905	DTA144ES	DIGITAL TRANSISTOR	
	Q906	DTC114YS	DIGITAL TRANSISTOR	
	Q907	2SD2144S (VW)	SI. TRANSISTOR	
		CAPACITORS		
	C010	QCF21HP-223A	0.022MF 50V CER. CAP.	
	C011	QETB1HM-106	10MF 50V E. CAP.	
	C012	QCS21HJ-271A	270PF 50V CER. CAP.	
	C013	QETB1EM-106	10MF 25V AL. E. CAP.	
	C014	QCS21HJ-101A	100PF 50V CER. CAP.	
	C015	QCS21HJ-5R0	5PF 50V CER. CAP.	
	C016	QETB1CM-476	47MF 16V AL. E. CAP.	
	C017	QCS22HJ-330	33PF 500V CER. CAP.	
	C018	QFLB1HJ-103	0.01MF 50V MYLAR CAP.	
	C019	QETB1HM-476	47MF 50V E. CAP.	
	C020	QCS22HJ-470A	47PF 500V CER. CAP.	
	C021	QETB1HM-225	2.2MF 50V AL. E. CAP.	
	C023	QCS22HJ-470A	47PF 500V CER. CAP.	
	C024	QFLB1HJ-223	0.022MF 50V MYLAR CAP.	J
		QFLB1HJ-473	0.047MF 50V MYLAR CAP.	C
	C025	QFLB1HJ-473	0.047MF 50V MYLAR CAP.	C
	C026	QCF21HP-223A	0.022MF 50V CER. CAP.	
	C027	QCY31HK-332Z	3300PF 50V CER. CAP.	
	C028	QCY31HK-332Z	3300PF 50V CER. CAP.	
	C064	QFLB1HJ-223	0.022MF 50V MYLAR CAP.	J
		QFLB1HJ-473	0.047MF 50V MYLAR CAP.	C
	C065	QFLB1HJ-473	0.047MF 50V MYLAR CAP.	C
	C481	QCB1HK-331Y	330PF 50V CER. CAP.	
	C482	QCHB1EZ-223	0.022MF 25V CER. CAP.	
	C521	QETB1HM-106	10MF 50V E. CAP.	
	C522	QCF21HP-103A	0.01MF 50V CER. CAP.	
	C523	QFLB1HJ-123	0.012MF 50V MYLAR CAP.	
	C524	QETB1HM-106	10MF 50V E. CAP.	
	C525	QCB1HK-101Y	100PF 50V CER. CAP.	
	C528	QETC1AM-476ZM	47MF 10V E. CAP.	
	C529	QETC1AM-476ZM	47MF 10V E. CAP.	
	C701	QETB1HM-106	10MF 50V E. CAP.	
	C702	QETB1HM-106	10MF 50V E. CAP.	
	C703	QCS21HJ-271A	270PF 50V CER. CAP.	
	C704	QCS21HJ-271A	270PF 50V CER. CAP.	
	C705	QCS21HJ-101A	100PF 50V CER. CAP.	
	C706	QCS21HJ-101A	100PF 50V CER. CAP.	
	C707	QETB1CM-476	47MF 16V AL. E. CAP.	
	C708	QETB1CM-476	47MF 16V AL. E. CAP.	
	C709	QCS21HJ-100	10PF 50V CER. CAP.	
	C710	QCS21HJ-100	10PF 50V CER. CAP.	
	C711	QCY31HK-152Z	1500PF 50V CER. CAP.	



## ■ Electrical Parts List (ENH-306)

△	Item	Parts Number	Description	Area
	C712	QCY31HK-152Z	1500PF 50V CER. CAP.	
	C713	QCS21HJ-680A	68PF 50V CER. CAP.	
	C714	QCS21HJ-680A	68PF 50V CER. CAP.	
	C715	QCS21HJ-680A	68PF 50V CER. CAP.	
	C716	QCS21HJ-680A	68PF 50V CER. CAP.	
	C717	QCS22HJ-220	22PF 500V CER. CAP.	
	C718	QCS22HJ-220	22PF 500V CER. CAP.	
	C719	QFLB1HJ-472	4700PF 50V MYLAR CAP.	
	C720	QFLB1HJ-472	4700PF 50V MYLAR CAP.	
	C722	QETB1EM-476	47MF 25V AL. E. CAP.	
	C723	QETB2AM-476	47MF 100V AL. E. CAP.	
	C724	QETB2AM-476	47MF 100V AL. E. CAP.	
	C725	QCS22HJ-470A	47PF 500V CER. CAP.	
	C726	QCS22HJ-470A	47PF 500V CER. CAP.	
	C727	QCS22HJ-470A	47PF 500V CER. CAP.	
	C728	QCS22HJ-470A	47PF 500V CER. CAP.	
	C729	QFLB1HJ-223	0.022MF 50V MYLAR CAP.	J
		QFLB1HJ-473	0.047MF 50V MYLAR CAP.	C
	C730	QFLB1HJ-223	0.022MF 50V MYLAR CAP.	J
		QFLB1HJ-473	0.047MF 50V MYLAR CAP.	C
	C731	QFLB1HJ-473	0.047MF 50V MYLAR CAP.	C
	C732	QFLB1HJ-473	0.047MF 50V MYLAR CAP.	C
	C733	QCF21HP-472	4700PF 50V CER. CAP.	
	C734	QCF21HP-472	4700PF 50V CER. CAP.	
	C735	QCF21HP-472	4700PF 50V CER. CAP.	
	C736	QCF21HP-472	4700PF 50V CER. CAP.	
	C741	QCF21HP-472	4700PF 50V CER. CAP.	
	C801	EEW7504-109T	10000MF E. CAP.	
	C802	EEW7504-109T	10000MF E. CAP.	
	C812	QETB1EM-107	100MF 25V AL. E. CAP.	
	C814	QETB1EM-107	100MF 25V AL. E. CAP.	
	C816	QETB1EM-107	100MF 25V AL. E. CAP.	
	C819	QETB1EM-107	100MF 25V AL. E. CAP.	
	C820	QETB1EM-107	100MF 25V AL. E. CAP.	
	C822	QETB1HM-476	47MF 50V E. CAP.	
	C823	QETB1HM-476	47MF 50V E. CAP.	
	C871	QCZ0205-155	1.5MF 25V C. CAP.	
	C901	QCF21HP-223A	0.022MF 50V CER. CAP.	
	C902	QCF21HP-223A	0.022MF 50V CER. CAP.	
	C903	QETB1HM-226E	22MF 50V E. CAP.	
	C904	QCF21HP-103A	0.01MF 50V CER. CAP.	
	C905	QCY31HK-102Z	1000PF 50V CER. CAP.	
	C906	QETC1AM-476ZM	47MF 10V E. CAP.	
	C909	QETB1CM-226	22MF 16V E. CAP.	
		RESISTORS		
	R011	QRD161J-222	2.2K 1/6W CARBON RES.	
	R012	QRD161J-104	100K 1/6W CARBON RES.	
	R013	QRD161J-123	12K 1/6W CARBON RES.	
	R014	QRD161J-162	1.6K 1/6W CARBON RES.	
	R015	QRD161J-104	100K 1/6W CARBON RES.	
	R016	QRD14CJ-181S	180 1/4W UNF. CARBON R	
△	R017	QRD14CJ-332SX	3.3K 1/4W UNF. CARBON R	
	R018	QRD167J-332	3.3K 1/6W CARBON RES.	
	R019	QRD167J-332	3.3K 1/6W CARBON RES.	
	R020	QRD167J-332	3.3K 1/6W CARBON RES.	
△	R023	QRD14CJ-120SX	12 1/4W UNF. CARBON R	
△	R024	QRD14CJ-100SX	10 1/4W UNF. CARBON R	
△	R025	QRD14CJ-561SX	560 1/4W UNF. CARBON R	
△	R026	QRD14CJ-100SX	10 1/4W UNF. CARBON R	
△	R027	QRD14CJ-120SX	12 1/4W UNF. CARBON R	
	R028	QRD161J-391	390 1/6W CARBON RES.	
	R029	ERT-D2WHL202S	2K 1/4W NEGATIVE THE	
	R030	QRD161J-183	18K 1/6W CARBON RES.	
	R031	QRD161J-123	12K 1/6W CARBON RES.	
△	R032	QRD125J-330	33 1/2W UNF. CARBON R	
△	R033	QRG022J-100A	10 2W OXIDE METAL	
	R034	QRD161J-104	100K 1/6W CARBON RES.	
△	R035	QRD14CJ-471SX	470 1/4W UNF. CARBON R	

△	Item	Parts Number	Description	Area
△	R036	QRD14CJ-471SX	470 1/4W UNF. CARBON R	
△	R037	QRG022J-562A	5.6K 2W OXIDE METAL	
	R038	QRD167J-751	750 1/6W CARBON RES.	
△	R039	QRD14CJ-100SX	10 1/4W UNF. CARBON R	
	R040	QRD161J-3R3	3.3 1/6W CARBON RES.	
	R043	QRD161J-102	1K 1/6W CARBON RES.	
	R045	QRD167J-151	150 1/6W CARBON RES.	
	R046	QRD167J-151	150 1/6W CARBON RES.	
	R047	QRD167J-151	150 1/6W CARBON RES.	
	R048	QRD167J-151	150 1/6W CARBON RES.	
△	R073	QRG022J-100A	10 2W OXIDE METAL	
	R074	QRD161J-104	100K 1/6W CARBON RES.	
	R481	QRD161J-100	10 1/6W CARBON RES.	
	R482	QRD161J-102	1K 1/6W CARBON RES.	
	R521	QRD161J-752	7.5K 1/6W CARBON RES.	
	R522	QRD161J-103	10K 1/6W CARBON RES.	
	R523	QRD161J-103	10K 1/6W CARBON RES.	
	R524	QRD167J-682	6.8K 1/6W CARBON RES.	
	R525	QRD161J-182	1.8K 1/6W CARBON RES.	
	R526	QRD161J-132	1.3K 1/6W CARBON RES.	
	R527	QRD161J-104	100K 1/6W CARBON RES.	
△	R529	QRZ0077-680	68 1/4W FUSIBLE RES.	
△	R530	QRZ0077-680	68 1/4W FUSIBLE RES.	
△	R531	QRD14CJ-681SX	680 1/4W UNF. CARBON R	
△	R532	QRD14CJ-681SX	680 1/4W UNF. CARBON R	
	R533	QRD161J-273	27K 1/6W CARBON RES.	
	R534	QRD161J-203	20K 1/6W CARBON RES.	
	R535	QRD161J-104	100K 1/6W CARBON RES.	
	R536	QRD167J-223	22K 1/6W CARBON RES.	
	R701	QRD161J-222	2.2K 1/6W CARBON RES.	
	R702	QRD161J-222	2.2K 1/6W CARBON RES.	
	R703	QRD161J-104	100K 1/6W CARBON RES.	
	R704	QRD161J-104	100K 1/6W CARBON RES.	
	R705	QRD161J-202	2K 1/6W CARBON RES.	
	R706	QRD161J-202	2K 1/6W CARBON RES.	
	R707	QRD161J-202	2K 1/6W CARBON RES.	
	R708	QRD161J-202	2K 1/6W CARBON RES.	
	R709	QRD167J-822	8.2K 1/6W CARBON RES.	
	R710	QRD167J-822	8.2K 1/6W CARBON RES.	
	R711	QRD161J-821	820 1/6W CARBON RES.	
	R712	QRD161J-821	820 1/6W CARBON RES.	
	R713	QRD161J-133Y	13K 1/6W CARBON RES.	
	R714	QRD161J-133Y	13K 1/6W CARBON RES.	
	R715	QRD161J-823	82K 1/6W CARBON RES.	
	R716	QRD161J-823	82K 1/6W CARBON RES.	
	R717	QRD12CJ-153SX	15K 1/2W UNF. CARBON R	
	R718	QRD12CJ-153SX	15K 1/2W UNF. CARBON R	
	R719	QRD161J-391	390 1/6W CARBON RES.	
	R720	QRD161J-391	390 1/6W CARBON RES.	
	R721	QRD14CJ-151SX	150 1/4W UNF. CARBON R	
	R722	QRD14CJ-151SX	150 1/4W UNF. CARBON R	
	R723	QRD167J-152	1.5K 1/6W CARBON RES.	
	R724	QRD167J-152	1.5K 1/6W CARBON RES.	
	R725	QRD161J-333	33K 1/6W CARBON RES.	
	R726	QRD161J-333	33K 1/6W CARBON RES.	
	R727	QRD161J-391	390 1/6W CARBON RES.	
	R728	QRD161J-391	390 1/6W CARBON RES.	
	R729	QRD161J-391	390 1/6W CARBON RES.	
	R730	QRD161J-391	390 1/6W CARBON RES.	
	R731	QRD161J-101	100 1/6W CARBON RES.	
	R732	QRD161J-101	100 1/6W CARBON RES.	
△	R733	QRD14CJ-120SX	12 1/4W UNF. CARBON R	
△	R734	QRD14CJ-120SX	12 1/4W UNF. CARBON R	
△	R735	QRG022J-562A	5.6K 2W OXIDE METAL	
	R739	QRD161J-201	200 1/6W CARBON RES.	
	R740	QRD161J-201	200 1/6W CARBON RES.	
	R741	QRD161J-201	200 1/6W CARBON RES.	
	R742	QRD161J-201	200 1/6W CARBON RES.	

## ■ Electorical Parts List (ENH-306)

△	Item	Parts Number	Description	Area
	R751	QRD161J-391	390 1/6W CARBON RES.	
	R752	QRD161J-391	390 1/6W CARBON RES.	
	R753	QRD161J-391	390 1/6W CARBON RES.	
	R754	QRD161J-391	390 1/6W CARBON RES.	
	R755	QRD161J-132	1.3K 1/6W CARBON RES.	
	R756	QRD161J-132	1.3K 1/6W CARBON RES.	
	R761	QRD161J-391	390 1/6W CARBON RES.	
	R762	QRD161J-391	390 1/6W CARBON RES.	
△	R765	QRD14CJ-272S	2.7K 1/4W UNF. CARBON R	
△	R766	QRD14CJ-272S	2.7K 1/4W UNF. CARBON R	
△	R767	QRD14CJ-271S	270 1/4W UNF. CARBON R	
△	R768	QRD14CJ-271S	270 1/4W UNF. CARBON R	
△	R769	QRD14CJ-100SX	10 1/4W UNF. CARBON R	
△		QRD14CJ-120SX	12 1/4W UNF. CARBON R	
△	R770	QRD14CJ-100SX	10 1/4W UNF. CARBON R	
△		QRD14CJ-120SX	12 1/4W UNF. CARBON R	
△	R771	QRD14CJ-120SX	12 1/4W UNF. CARBON R	
△	R772	QRD14CJ-120SX	12 1/4W UNF. CARBON R	
	R773	QRZ0197-R22	0.22 1W NETWORK RES.	
	R774	QRZ0197-R22	0.22 1W NETWORK RES.	
△	R775	QRD129J-470	47 1/2W UNF. CARBON R	
△	R776	QRD129J-470	47 1/2W UNF. CARBON R	
△	R777	ORG022J-100A	10 2W OXIDE METAL	
△	R778	ORG022J-100A	10 2W OXIDE METAL	
△	R779	QRD14CJ-100SX	10 1/4W UNF. CARBON R	
△	R780	QRD14CJ-100SX	10 1/4W UNF. CARBON R	
△	R781	QRD14CJ-100SX	10 1/4W UNF. CARBON R	
△	R782	QRD14CJ-100SX	10 1/4W UNF. CARBON R	
△	R783	QRD14CJ-100SX	10 1/4W UNF. CARBON R	
△	R784	QRD14CJ-100SX	10 1/4W UNF. CARBON R	
△	R785	QRD14CJ-100SX	10 1/4W UNF. CARBON R	
△	R786	QRD14CJ-100SX	10 1/4W UNF. CARBON R	
	R787	QRD14CJ-103SX	10K 1/4W CARBON RES.	
	R788	QRD161J-103	10K 1/6W CARBON RES.	
	R789	QRD161J-473	47K 1/6W CARBON RES.	
	R799	QRZ0197-R22	0.22 1W NETWORK RES.	
	R801	QRD161J-104	100K 1/6W CARBON RES.	
	R802	QRD161J-104	100K 1/6W CARBON RES.	
△	R811	QRD14CJ-120SX	12 1/4W UNF. CARBON R	
△	R813	QRD14CJ-122SX	1.2K 1/4W UNF. CARBON R	
△	R819	QRD14CJ-100SX	10 1/4W UNF. CARBON R	
△	R822	QRD14CJ-272S	2.7K 1/4W UNF. CARBON R	
△	R823	QRD14CJ-220S	22 1/4W UNF. CARBON R	
△	R825	QRD14CJ-332SX	3.3K 1/4W UNF. CARBON R	
△	R826	QRD14CJ-120SX	12 1/4W UNF. CARBON R	
△	R828	QRD12CJ-153SX	15K 1/2W UNF. CARBON R	
△	R834	QRD14CJ-3R9S	3.9 1/4W UNF. CARBON R	
△	R835	QRD12CJ-391S	390 1/2W UNF. CARBON R	
△	R838	QRD12CJ-2R2SX	2.2 1/2W UNF. CARBON R	
△	R843	QRD14CJ-100SX	10 1/4W UNF. CARBON R	
△	R850	QRD14CJ-331SX	330 1/4W UNF. CARBON R	
△	R851	QRD14CJ-100SX	10 1/4W UNF. CARBON R	
	R901	QRD161J-102	1K 1/6W CARBON RES.	
	R902	QRD161J-102	1K 1/6W CARBON RES.	
	R903	QRD167J-562	5.6K 1/6W CARBON RES.	
	R904	QRD167J-562	5.6K 1/6W CARBON RES.	
	R905	QRD161J-123	12K 1/6W CARBON RES.	
	R906	QRD161J-123	12K 1/6W CARBON RES.	
	R907	QRD161J-102	1K 1/6W CARBON RES.	
	R908	QRD161J-102	1K 1/6W CARBON RES.	
	R909	QRD161J-103	10K 1/6W CARBON RES.	
	R911	QRD167J-332	3.3K 1/6W CARBON RES.	
	R912	QRD161J-473	47K 1/6W CARBON RES.	
	R913	QRD161J-104	100K 1/6W CARBON RES.	
	R914	QRD161J-823	82K 1/6W CARBON RES.	
	R915	QRD161J-823	82K 1/6W CARBON RES.	
	R916	QRD161J-563	56K 1/6W CARBON RES.	
	R917	QRD161J-683	68K 1/6W CARBON RES.	

△	Item	Parts Number	Description	Area
	R918	QRD161J-392	3.9K 1/6W CARBON RES.	
	R921	QRD161J-224	220K 1/6W CARBON RES.	
	R922	QRD167J-562	5.6K 1/6W CARBON RES.	
△	R929	QRD14CJ-470SX	47 1/4W UNF. CARBON R	
△	R941	ORG022J-471A	470 2W OXIDE METAL	
△	R942	ORG022J-471A	470 2W OXIDE METAL	
	R951	QRD161J-333	33K 1/6W CARBON RES.	
	R952	QRD161J-333	33K 1/6W CARBON RES.	
	R953	QRD161J-333	33K 1/6W CARBON RES.	
	R965	QRD161J-823	82K 1/6W CARBON RES.	
	R966	QRD161J-124	120K 1/6W CARBON RES.	
	R967	QRD161J-105	1M 1/6W CARBON RES.	
	R968	QRD161J-103	10K 1/6W CARBON RES.	
	R969	QRD161J-3R3	3.3 1/6W CARBON RES.	
	VR791	QVPA601-501A	500 TRIMMER RES.	
	VR792	QVPA601-501A	500 TRIMMER RES.	
		OTHERS		
		EMW10701-002	PRINTED BOARD	
		SBSG3008CC	TAPPING SCREW	
	J481	QMS3501-021	PIN JACK	
	J901	QMS6022-V01	MICROPHONE JACK	
	L011	EQL0011-R45J1	INDUCTOR	
	L701	EQL0001-1R0	INDUCTOR	
	L702	EQL0001-1R0	INDUCTOR	
	S001	QST4241-E05J2	PUSH SWITCH	
	CN101	EMV7163-012	CONNECT TERMINAL	
	CN108	EWS293-0140	SOCKET WIRE ASSY	
	CN109	EWS293-0120	SOCKET WIRE	
	CN118	VMC0075-003	CONNECTOR	
	CN119	VMC0075-003	CONNECTOR	
	CN311	VMC0075-008N	CONNECT TERMINAL	
	CN411	VMC0163-021	CONNECT TERMINAL	
	CN501	EMV7163-011	CONNECT TERMINAL	
	CN601	EMV7163-007	CONNECT TERMINAL	
	CN602	EMV7163-011	CONNECT TERMINAL	
	CN701	EMV7163-006	CONNECT TERMINAL	
	CN801	EMV7163-007	CONNECT TERMINAL	
	CN812	EMV5129-003	CONNECTOR	
	CN813	VMC0178-003	CONNECT TERMINAL	
	CN814	VMC0178-003	CONNECT TERMINAL	
	EP001	EMZ4002-002Z	EARTH PLATE	
	EP003	EMZ4002-002Z	EARTH PLATE	
	EP004	EMZ4002-002Z	EARTH PLATE	
	EP005	EMZ4002-002Z	EARTH PLATE	
	EP006	EMZ4002-002Z	EARTH PLATE	
	EP007	EMZ4002-002Z	EARTH PLATE	
	FW901	EWR33D-08SS	FLAT WIRE	
	FW903	EWR36D-45SS	FLAT WIRE	
	HS801	E70306-001	HEAT SINK	
	HS803	E70306-001	HEAT SINK	
	HS804	E70306-001	HEAT SINK	
	HS805	E70306-001	HEAT SINK	
	RY011	ESK7D24-2120	RELAY	
	RY901	ESK7D24-2120	RELAY	
	ST011	EMB90TV-601G	SPEAKER TERMINAL	
	ST901	EMB00TV-801A	TERMINAL	
	TP751	QMV5005-004K	PLUG ASSY	

## ■ Electrical Parts List (ENB-252)

Q.	Item	Parts Number	Description	Area
		I. C. S		
	IC401	MN101C01DAC1	I. C.	
	IC402	GP1U271X	INFRARED DETECT UNIT	
	IC403	PST600E-T	I. C (MONO-ANALOG)	
	IC411	MN171602JAAN	I. C (MICRO-COMPUTER)	
		DIODES		
	D050	1SS133	SI. DIODE	
	D051	MTZ18JC	ZENER DIODE	
	D052	1SS133	SI. DIODE	
	D053	1SS133	SI. DIODE	
	D061	1SS133	SI DIODE	
	D062	1SS133	SI DIODE	
	D292	1SS133	SI. DIODE	
	D404	1SS133	SI. DIODE	
	D405	1SS133	SI. DIODE	
	D406	1SS133	SI. DIODE	
	D407	1SS133	SI. DIODE	
	D408	1SS133	SI. DIODE	
	D409	1SS133	SI. DIODE	
	D415	1SR139-200	SI DIODE	
	D416	1SR139-200	SI DIODE	
	D417	1SR139-200	SI DIODE	
	D418	1SS133	SI. DIODE	
	D419	1SS133	SI DIODE	
	D422	1SS133	SI. DIODE	
	D425	SLR-342MC-112	L. E. D.	
	D427	SLR-342VC3F	L. E. D.	
	D431	SLR-342MCA47	L. E. D.	
	D432	SLR-342MCA47	L. E. D.	
	D433	SLR-342MCA47	L. E. D.	
	D435	SLR-342MCA47	L. E. D.	
	D436	SLR-342MCA47	L. E. D.	
	D437	SLR-342MCA47	L. E. D.	
	D438	SLR-342MCA47	L. E. D.	
	D439	SLR-342MCA47	L. E. D.	
	D440	SLR-342DCA47	L. E. D.	
	D441	SLR-342DCA47	L. E. D.	
	D442	SLR-342DCA47	L. E. D.	
	D443	SLR-342DCA47	L. E. D.	
	D444	SLR-342DCA47	L. E. D.	
	D445	SLR-342DCA47	L. E. D.	
	D461	1SS133	SI DIODE	
	D462	1SS133	SI. DIODE	
	D463	1SS133	SI. DIODE	
	D464	1SS133	SI. DIODE	
	D471	1SS133	SI. DIODE	
	D857	MTZ6.2JC	ZENER DIODE	
	D858	1SS133	SI. DIODE	
	D871	1SR139-200	SI DIODE	
	D872	1SR139-200	SI. DIODE	
	D873	1SR139-200	SI. DIODE	
	D874	1SR139-200	SI DIODE	
		TRANSISTORS		
	Q051	2SC2240 (GR. BL)	SI. TRANSISTOR	
	Q052	2SC2240 (GR. BL)	SI. TRANSISTOR	
	Q053	2SA1038 (R. S)	SI. TRANSISTOR	
	Q055	2SC2235 (O. Y)	SI. TRANSISTOR	
	Q057	2SA965 (Y)	SI. TRANSISTOR	
	Q059	2SC1775AV (F1)	SI. TRANSISTOR	
	Q061	2SC2389 (S. E)	SI. TRANSISTOR	
	Q062	2SA1038 (R. S)	SI. TRANSISTOR	
	Q401	DTC114YS	DIGITAL TRANSISTOR	
	Q402	DTC114TN	DIGITAL TRANSISTOR	
	Q403	DTC144WS	DIGITAL TRANSISTOR	
	Q404	DTC114YS	DIGITAL TRANSISTOR	
	Q405	DTC144ES	DIGITAL TRANSISTOR	
	Q406	DTC114YS	DIGITAL TRANSISTOR	
	Q410	DTC144ES	DIGITAL TRANSISTOR	

Q.	Item	Parts Number	Description	Area
	Q411	DTA114YS	DIGITAL TRANSISTOR	
	Q852	2SC2235 (O. Y)	SI. TRANSISTOR	
	Q853	DTC123YS	DIGITAL TRANSISTOR	
		CAPACITORS		
	C001	QCZ9019-472	4700PF C. CAP.	
	C050	QCHB1EZ-223	0.022MF 25V CER. CAP.	
	C051	QETB1HM-106	10MF 50V E. CAP.	
	C052	QCS21HJ-271A	270PF 50V CER. CAP.	
	C053	QETB1EM-106	10MF 25V AL. E. CAP.	
	C054	QCS21HJ-101A	100PF 50V CER. CAP.	
	C055	QCS21HJ-5R0	5PF 50V CER. CAP.	
	C056	QETB1CM-476	47MF 16V AL. E. CAP.	
	C057	QCS22HJ-330	33PF 500V CER. CAP.	
	C058	QFLB1HJ-103	0.01MF 50V MYLAR CAP.	
	C059	QETB1HM-476	47MF 50V E. CAP.	
	C060	QCS22HJ-470A	47PF 500V CER. CAP.	
	C061	QETB1HM-225	2.2MF 50V AL. E. CAP.	
	C063	QCS22HJ-470A	47PF 500V CER. CAP.	
	C066	QCF21HP-223A	0.022MF 50V CER. CAP.	
	C067	QCY31HK-332Z	3300PF 50V CER. CAP.	
	C068	QCY31HK-332Z	3300PF 50V CER. CAP.	
	C291	QCS31HJ-471Z	470PF 50V CER. CAP.	
	C294	QCS31HJ-681Z	680PF 50V CER. CAP.	
	C401	QETB1AM-227	220MF 10V E. CAP.	
	C402	QCZ0202-155	1.5MF 25V CER. RES.	
	C403	QEAD0HZ-10AZM	AL. E. CAP.	
	C404	QEK51HM-225G	2.2MF 50V AL. E. CAP.	
	C405	QCHB1EZ-223	0.022MF 25V CER. CAP.	
	C406	QCBB1HK-331Y	330PF 50V CER. CAP.	
	C407	QCVB1CM-103Y	0.01MF 16V CER. CAP.	
	C408	QCHB1EZ-223	0.022MF 25V CER. CAP.	
	C411	QCZ0202-155	1.5MF 25V CER. RES.	
	C412	QETC1AM-107ZN	100MF 10V E. CAP.	
	C420	QETB1AM-227	220MF 10V E. CAP.	
	C421	QETB1HM-475E	4.7MF 50V E. CAP.	
	C422	QETB1HM-106	10MF 50V E. CAP.	
	C423	QETB1HM-475E	4.7MF 50V E. CAP.	
	C850	QETB1CM-476	47MF 16V AL. E. CAP.	
	C851	QFN82AK-472	4700PF 100V METAL MYLAR	
	C852	QETC1EM-227ZN	220MF 25V AL. E. CAP.	
		RESISTORS		
	R001	QRZ9044-335	3.3M COMPOSITION	
	R051	QRD161J-222	2.2K 1/6W CARBON RES.	
	R052	QRD161J-104	100K 1/6W CARBON RES.	
	R053	QRD161J-123	12K 1/6W CARBON RES.	
	R054	QRD161J-182	1.8K 1/6W CARBON RES.	
	R055	QRD161J-104	100K 1/6W CARBON RES.	
	R056	QRD14CJ-181S	180 1/4W UNF. CARBON R	
	R057	QRD14CJ-332SX	3.3K 1/4W UNF. CARBON R	
	R058	QRD167J-332	3.3K 1/6W CARBON RES.	
	R059	QRD167J-332	3.3K 1/6W CARBON RES.	
	R060	QRD167J-332	3.3K 1/6W CARBON RES.	
	R063	QRD14CJ-120SX	12 1/4W UNF. CARBON R	
	R064	QRD14CJ-100SX	10 1/4W UNF. CARBON R	
	R065	QRD14CJ-561SX	560 1/4W UNF. CARBON R	
	R066	QRD14CJ-100SX	10 1/4W UNF. CARBON R	
	R067	QRD14CJ-120SX	12 1/4W UNF. CARBON R	
	R068	QRD161J-391	390 1/6W CARBON RES.	
	R069	ERT-D2WHL202S	2K 1/4W NEGATIVE THE	
	R070	QRD161J-183	18K 1/6W CARBON RES.	
	R071	QRD161J-123	12K 1/6W CARBON RES.	
	R072	QRD125J-330	33 1/2W UNF. CARBON R	
	R077	ORG022J-562A	5.6K 2W OXIDE METAL	
	R078	QRD167J-751	750 1/6W CARBON RES.	
	R083	QRD161J-102	1K 1/6W CARBON RES.	
	R087	QRD14CJ-331SX	330 1/4W UNF. CARBON R	
	R088	QRD14CJ-331SX	330 1/4W UNF. CARBON R	
	R090	QRZ0197-R22	0.22 1W NETWORK RES.	

## ■ Electrical Parts List (ENB-252)

△	Item	Parts Number	Description	Area
	R095	QRD167J-151	150 1/6W CARBON RES.	
	R096	QRD167J-151	150 1/6W CARBON RES.	
	R097	QRD167J-151	150 1/6W CARBON RES.	
	R098	QRD167J-151	150 1/6W CARBON RES.	
	R291	QRD161J-221	220 1/6W CARBON RES.	
	R292	QRD161J-221	220 1/6W CARBON RES.	
	R293	QRD161J-221	220 1/6W CARBON RES.	
	R299	QRD161J-102	1K 1/6W CARBON RES.	
	R403	QRD161J-101	100 1/6W CARBON RES.	
	R410	QRD167J-223	22K 1/6W CARBON RES.	
	R411	QRD161J-472	4.7K 1/6W CARBON RES.	
	R414	QRD161J-103	10K 1/6W CARBON RES.	
	R415	QRD161J-103	10K 1/6W CARBON RES.	
	R416	QRD161J-103	10K 1/6W CARBON RES.	
	R417	QRD161J-103	10K 1/6W CARBON RES.	
	R418	QRD161J-471	470 1/6W CARBON RES.	
	R419	QRD161J-103	10K 1/6W CARBON RES.	
	R420	QRD161J-103	10K 1/6W CARBON RES.	
	R421	QRD161J-103	10K 1/6W CARBON RES.	
	R422	QRD161J-103	10K 1/6W CARBON RES.	
	R425	QRD161J-221	220 1/6W CARBON RES.	
	R427	QRD161J-221	220 1/6W CARBON RES.	
△	R428	QRD14CJ-220S	22 1/4W UNF. CARBON R	
	R429	QRD161J-103	10K 1/6W CARBON RES.	
	R430	QRD161J-104	100K 1/6W CARBON RES.	
	R431	QRD161J-221	220 1/6W CARBON RES.	
	R432	QRD161J-221	220 1/6W CARBON RES.	
	R433	QRD161J-221	220 1/6W CARBON RES.	
	R434	QRD161J-221	220 1/6W CARBON RES.	
	R435	QRD161J-221	220 1/6W CARBON RES.	
	R436	QRD161J-221	220 1/6W CARBON RES.	
	R437	QRD161J-221	220 1/6W CARBON RES.	
	R440	QRD161J-221	220 1/6W CARBON RES.	
	R442	QRD161J-221	220 1/6W CARBON RES.	
	R443	QRD161J-221	220 1/6W CARBON RES.	
	R444	QRD161J-221	220 1/6W CARBON RES.	
	R445	QRD161J-221	220 1/6W CARBON RES.	
	R447	QRD161J-221	220 1/6W CARBON RES.	
	R448	QRD161J-221	220 1/6W CARBON RES.	
	R449	QRD161J-221	220 1/6W CARBON RES.	
	R450	QRD161J-221	220 1/6W CARBON RES.	
	R451	QRD161J-221	220 1/6W CARBON RES.	
	R452	QRD161J-221	220 1/6W CARBON RES.	
	R453	QRD161J-221	220 1/6W CARBON RES.	
	R454	QRD161J-221	220 1/6W CARBON RES.	
	R455	QRD161J-221	220 1/6W CARBON RES.	
	R456	QRD161J-221	220 1/6W CARBON RES.	
	R457	QRD161J-221	220 1/6W CARBON RES.	
	R458	QRD161J-221	220 1/6W CARBON RES.	
	R459	QRD161J-221	220 1/6W CARBON RES.	
	R460	QRD161J-221	220 1/6W CARBON RES.	
	R461	QRD161J-221	220 1/6W CARBON RES.	
	R462	QRD161J-221	220 1/6W CARBON RES.	
	R466	QRD161J-221	220 1/6W CARBON RES.	
	R467	QRD161J-103	10K 1/6W CARBON RES.	
	R470	QRD161J-221	220 1/6W CARBON RES.	
	R474	QRD161J-221	220 1/6W CARBON RES.	
	R480	QRD161J-104	100K 1/6W CARBON RES.	
	R481	QRD161J-104	100K 1/6W CARBON RES.	
	R482	QRD161J-104	100K 1/6W CARBON RES.	
	R483	QRD161J-104	100K 1/6W CARBON RES.	
	R484	QRD161J-104	100K 1/6W CARBON RES.	
△	R860	QRD14CJ-100SX	10 1/4W UNF. CARBON R	
△	R861	QRD14CJ-100SX	10 1/4W UNF. CARBON R	
	R863	QRD161J-821	820 1/6W CARBON RES.	
	RA411	QRD049J-103	10K 1/10WRES.	
		OTHERS		
		ENW10702-002	PRINTED BOARD	

△	Item	Parts Number	Description	Area
		QWE881-14RR	VINYL WIRE	
		QWE886-14RR	VINYL WIRE	
	J291	QMS3L10-0A0	MICROPHONE JACK	
	J292	QMS3L10-0A0	MICROPHONE JACK	
	J293	QMS3L10-0A0	MICROPHONE JACK	
	J295	EMN00TV-119AJ4	PIN JACK	
	L051	EQL0011-R45J1	INDUCTOR	
	S005	QSS7A12-E01	SLIDE SWITCH	
	S401	ESP0001-023M	TACT SWITCH	
	S403	ESP0001-023M	TACT SWITCH	
	S405	ESP0001-023M	TACT SWITCH	
	S406	ESP0001-023M	TACT SWITCH	
	S407	ESP0001-023M	TACT SWITCH	
	S408	ESP0001-023M	TACT SWITCH	
	S409	ESP0001-023M	TACT SWITCH	
	S410	ESP0001-023M	TACT SWITCH	
	S411	ESP0001-023M	TACT SWITCH	
	S412	ESP0001-023M	TACT SWITCH	
	S413	ESP0001-023M	TACT SWITCH	
	S414	ESP0001-023M	TACT SWITCH	
	S415	ESP0001-023M	TACT SWITCH	
	S416	ESP0001-023M	TACT SWITCH	
	S417	ESP0001-023M	TACT SWITCH	
△	T002	ETP1000-41JA	POWER TRANSFORMER	
	X401	ECX0008-000KMZ	CRYSTAL	
	X411	ECXP6R0-001ZA	CRYSTAL	
	BK400	E309106-001SM	FL HOLDER	
	CN301	EWS268-A920J	SOCKET WIRE ASSY	
	CN302	EWS293-0116	SOCKET WIRE	
	CN401	VMC0163-R21	CONNECT TERMINAL	
	CN402	EWS26A-A210	SOCKET WIRE ASSY	
	CN403	EWS26E-A210	SOCKET WIRE ASSY	
	CN404	EWS269-A422J	SOCKET WIRE ASSY	
	CN405	VMC0163-R13	CONNECT TERMINAL	
	CN408	EWS294-2745	SOCKET WIRE ASSY	
	CN412	EMV5109-010A	CONNECT TERMINAL	
	CN413	EMV5109-014A	PIN PLUG	
	CN711	EMV5163-006R	CONNECT TERMINAL	
	CN804	VMC0177-003	CONNECT TERMINAL	
	D1400	ELU0001-215	FLUORESCENT DISPLAY TUBE	
	EPO01	EMZ4002-002Z	EARTH PLATE	
	EPO05	E409182-001SM	EARTH TERMINAL	
	FC001	EMG7331-003Z	FUSE CLIP	
	FC002	EMG7331-003Z	FUSE CLIP	
	FS001	E3400-444	FELT SPACER	
	FS002	E3400-444	FELT SPACER	
	HL401	VYH7653-002	I. C. PROTECTOR	
	JS401	QJ34003-E01	PUSH SWITCH	
	RY002	ESK1D12-119J3	RELAY	
	TA001	EMZ4001-002Z	TAB	
	TA002	EMZ4001-002Z	TAB	

## ■ Electrical Parts List (ENC-138)

Item	Parts Number	Description	Area
	I. C. S		
IC221	NJM2279D	I. C (MONO-ANALOG)	
IC222	M35012-120SP	I. C (M)	
IC301	NJM4580DD	I. C (MONO-ANALOG)	
IC305	TC9212P	I. C (DIGI-MOS)	
IC306	NJM4580LD	I. C (MONO-ANALOG)	
IC307	TC9213P	I. C (DIGI-MOS)	
IC308	NJM4580LD	I. C (MONO-ANALOG)	
IC311	BA15218N	I. C (MONO-ANALOG)	
IC321	TC9274N-007	I. C (M)	
IC551	LC7522	I. C (DIGI-MOS)	
IC552	M5243P12	I. C (MONO-ANALOG)	
IC601	LA2786	I. C (MONO-ANALOG)	
IC641	LV1016	I. C (M)	
	DIODES		
D225	1SS133	SI. DIODE	
D227	1SS133	SI. DIODE	
D229	1SS133	SI. DIODE	
D251	MTZ6.2JC	ZENER DIODE	
D252	1SR139-200	SI. DIODE	
D253	1SR139-200	SI. DIODE	
D254	MTZ39JCT-77	ZENER DIODE	
D255	1SR139-200	SI. DIODE	
D261	1SR139-200	SI. DIODE	
D262	1SR139-200	SI. DIODE	
D263	10E2-FD	DIODE	
D264	10E2-FD	DIODE	
D265	1SS133	SI. DIODE	
D551	MTZ6.8JC	ZENER DIODE	
D552	MTZ6.8JC	ZENER DIODE	
D881	U6SBA20	DIODE	
D884	30D2FC	GE DIODE	
D885	30D2FC	GE DIODE	
D886	30D2FC	GE DIODE	
D887	30D2FC	GE DIODE	
D888	1SS133	SI. DIODE	
	TRANSISTORS		
Q221	2SC1740LN (R, S)	SI. TRANSISTOR	
Q222	2SC1740LN (R, S)	SI. TRANSISTOR	
Q223	2SC1740LN (R, S)	SI. TRANSISTOR	
Q251	2SB1357 (E, F)	SI. TRANSISTOR	
Q252	2SC2240 (GR, BL)	SI. TRANSISTOR	
Q253	DTC114YS	DIGITAL TRANSISTOR	
Q254	DTA144ES	DIGITAL TRANSISTOR	
Q255	DTC114ES	DIGITAL TRANSISTOR	
Q301	2SD2144S (VW)	SI. TRANSISTOR	
Q302	2SD2144S (VW)	SI. TRANSISTOR	
Q303	DTA144ES	DIGITAL TRANSISTOR	
Q306	2SD2144S (VW)	SI. TRANSISTOR	
	CAPACITORS		
C221	QETB0JM-477	470MF 6.3V AL. E. CAP.	
C222	QETB1CM-476	47MF 16V AL. E. CAP.	
C223	QCVB1CM-103Y	0.01MF 16V CER. CAP.	
C224	QCVB1CM-103Y	0.01MF 16V CER. CAP.	
C225	QCZ0205-155	1.5MF 25V C. CAP.	
C226	QETB1HM-105	1MF 50V AL. E. CAP.	
C227	QCS21HJ-100	10PF 50V CER. CAP.	
C228	QCS21HJ-100	10PF 50V CER. CAP.	
C229	QCS21HJ-150	15PF 50V CER. CAP.	
C230	QCS21HJ-270	27PF 50V CER. CAP.	
C231	QETB1EM-107	100MF 25V AL. E. CAP.	
C232	QETB1HM-106	10MF 50V E. CAP.	
C233	QETB1HM-106	10MF 50V E. CAP.	
C234	QCS21HJ-470	47PF 50V CER. CAP.	
C235	QCS21HJ-470	47PF 50V CER. CAP.	
C236	QETB0JM-108N	1000MF 6.3V E. CAP.	
C238	QETB1EM-476	47MF 25V AL. E. CAP.	
C240	QCXB1CM-472Y	4700PF 16V CER. CAP.	

Item	Parts Number	Description	Area
C241	QCB1HK-101Y	100PF 50V CER. CAP.	
C242	QCB1HK-181Y	180PF 50V CER. CAP.	
C251	QETB1HM-227	220MF 50V E. CAP.	
C252	QETB1JM-227	220MF 63V AL. E. CAP.	
C253	QETB1HM-105	1MF 50V AL. E. CAP.	
C254	QETB1HM-226E	22MF 50V E. CAP.	
C255	QETB1HM-226E	22MF 50V E. CAP.	
C259	QFLB1HJ-473	0.047MF 50V MYLAR CAP.	
C260	QFLB1HJ-473	0.047MF 50V MYLAR CAP.	
C262	QETB1VM-228N	2200MF 35V E. CAP.	
C264	QFN82AJ-104	0.1MF 100V MYLAR CAP.	
C265	QFN82AJ-104	0.1MF 100V MYLAR CAP.	
C266	QETB1HM-225	2.2MF 50V AL. E. CAP.	
C267	QFN82AJ-104	0.1MF 100V MYLAR CAP.	
C268	QETB1VM-228N	2200MF 35V E. CAP.	
C269	QFLB1HJ-104	0.1MF 50V MYLAR CAP.	
C300	QCF21HP-223A	0.022MF 50V CER. CAP.	
C301	QETB1HM-475E	4.7MF 50V E. CAP.	
C302	QETB1HM-475E	4.7MF 50V E. CAP.	
C303	QCS21HJ-101A	100PF 50V CER. CAP.	
C304	QCS21HJ-101A	100PF 50V CER. CAP.	
C305	QFLB1HJ-182	1800PF 50V MYLAR CAP.	
C306	QFLB1HJ-182	1800PF 50V MYLAR CAP.	
C307	QFLB1HJ-682	6800PF 50V MYLAR CAP.	
C308	QFLB1HJ-682	6800PF 50V MYLAR CAP.	
C309	QCS21HJ-101A	100PF 50V CER. CAP.	
C310	QCS21HJ-101A	100PF 50V CER. CAP.	
C311	QETB1HM-475E	4.7MF 50V E. CAP.	
C312	QETB1HM-475E	4.7MF 50V E. CAP.	
C313	QETC1AM-107ZN	100MF 10V E. CAP.	
C314	QETC1AM-107ZN	100MF 10V E. CAP.	
C315	QETB1CM-476	47MF 16V AL. E. CAP.	
C316	QETB1CM-476	47MF 16V AL. E. CAP.	
C319	QCF21HP-223A	0.022MF 50V CER. CAP.	
C320	QCF21HP-223A	0.022MF 50V CER. CAP.	
C321	QETB1EM-226N	22MF 25V E. CAP.	
C322	QETB1EM-226N	22MF 25V E. CAP.	
C341	QETB1HM-475E	4.7MF 50V E. CAP.	
C342	QETB1HM-475E	4.7MF 50V E. CAP.	
C345	QETB1EM-226N	22MF 25V E. CAP.	
C346	QETB1EM-226N	22MF 25V E. CAP.	
C347	QCF21HP-223A	0.022MF 50V CER. CAP.	
C348	QCF21HP-223A	0.022MF 50V CER. CAP.	
C351	QETB1HM-225	2.2MF 50V AL. E. CAP.	
C352	QETB1HM-225	2.2MF 50V AL. E. CAP.	
C353	QETB1HM-106	10MF 50V E. CAP.	
C354	QETB1HM-106	10MF 50V E. CAP.	
C355	QETB0JM-107	100MF 6.3V AL. E. CAP.	
C359	QETB1HM-475E	4.7MF 50V E. CAP.	
C360	QETB1HM-475E	4.7MF 50V E. CAP.	
C361	QETB1HM-475E	4.7MF 50V E. CAP.	
C362	QETB1HM-475E	4.7MF 50V E. CAP.	
C375	QCHB1EZ-223	0.022MF 25V CER. CAP.	
C376	QCHB1EZ-223	0.022MF 25V CER. CAP.	
C377	QCB1HK-561Y	560PF 50V CER. CAP.	
C378	QCB1HK-561Y	560PF 50V CER. CAP.	
C379	QFV81HJ-154	0.15MF 50V THIN FILM CAP.	
C380	QFV81HJ-154	0.15MF 50V THIN FILM CAP.	
C381	QETB1HM-106	10MF 50V E. CAP.	
C382	QETB1HM-106	10MF 50V E. CAP.	
C383	QETB1HM-225	2.2MF 50V AL. E. CAP.	
C384	QETB1HM-225	2.2MF 50V AL. E. CAP.	
C385	QETB1HM-475E	4.7MF 50V E. CAP.	
C386	QETB1HM-475E	4.7MF 50V E. CAP.	
C387	QETB1HM-475E	4.7MF 50V E. CAP.	
C388	QETB1HM-475E	4.7MF 50V E. CAP.	
C391	QCHB1EZ-223	0.022MF 25V CER. CAP.	
C392	QCHB1EZ-223	0.022MF 25V CER. CAP.	

## ■ Electrical Parts List (ENG-138)

△	Item	Parts Number	Description	Area
	C395	QCBB1HK-561Y	560PF 50V CER. CAP.	
	C396	QETB1EM-476	47MF 25V AL E. CAP.	
	C397	QETB1EM-476	47MF 25V AL E. CAP.	
	C398	QETB1EM-476	47MF 25V AL E. CAP.	
	C399	QETB1EM-476	47MF 25V AL E. CAP.	
	C551	QETB1HM-475E	4.7MF 50V E. CAP.	
	C552	QETB1HM-475E	4.7MF 50V E. CAP.	
	C553	QCBB1HK-101Y	100PF 50V CER. CAP.	
	C554	QCBB1HK-101Y	100PF 50V CER. CAP.	
	C555	QETB1HM-475E	4.7MF 50V E. CAP.	
	C556	QETB1HM-475E	4.7MF 50V E. CAP.	
	C557	QER51HM-475	4.7MF 50V AL E. CAP.	
	C558	QER51HM-475	4.7MF 50V AL E. CAP.	
	C559	QETB1HM-475E	4.7MF 50V E. CAP.	
	C560	QETB1HM-475E	4.7MF 50V E. CAP.	
	C563	QCHB1EZ-223	0.022MF 25V CER. CAP.	
	C564	QETB1CM-226	22MF 16V E. CAP.	
	C565	QCHB1EZ-223	0.022MF 25V CER. CAP.	
	C566	QETB1CM-226	22MF 16V E. CAP.	
	C567	QCHB1EZ-223	0.022MF 25V CER. CAP.	
	C569	QCSB1HJ-470	47PF 50V CER. CAP.	
	C570	QCSB1HJ-470	47PF 50V CER. CAP.	
	C571	QFV81HJ-333	0.033MF 50V THIN FILM CAP.	
	C572	QFV81HJ-333	0.033MF 50V THIN FILM CAP.	
	C573	QETB1HM-105	1MF 50V AL E. CAP.	
	C574	QETB1HM-105	1MF 50V AL E. CAP.	
	C575	QFLB1HJ-332	3300PF 50V MYLAR CAP.	
	C576	QFLB1HJ-332	3300PF 50V MYLAR CAP.	
	C577	QFV81HJ-104	0.1MF 50V THIN FILM CAP.	
	C578	QFV81HJ-104	0.1MF 50V THIN FILM CAP.	
	C579	QCS31HJ-331Z	330PF 50V CER. CAP.	
	C580	QCS31HJ-331Z	330PF 50V CER. CAP.	
	C581	QCF21HP-103A	0.01MF 50V CER. CAP.	
	C582	QCF21HP-103A	0.01MF 50V CER. CAP.	
	C601	QETB1HM-105	1MF 50V AL E. CAP.	
	C602	QETB1HM-105	1MF 50V AL E. CAP.	
	C603	QFLB1HJ-104	0.1MF 50V MYLAR CAP.	
	C604	QFLB1HJ-104	0.1MF 50V MYLAR CAP.	
	C605	QFLB1HJ-104	0.1MF 50V MYLAR CAP.	
	C606	QFLB1HJ-104	0.1MF 50V MYLAR CAP.	
	C607	QETB1HM-474	0.47MF 50V E. CAP.	
	C608	QETB1HM-474	0.47MF 50V E. CAP.	
	C609	QETB1HM-475E	4.7MF 50V E. CAP.	
	C610	QETB1HM-475E	4.7MF 50V E. CAP.	
	C611	QETB1HM-474	0.47MF 50V E. CAP.	
	C612	QETB1HM-474	0.47MF 50V E. CAP.	
	C613	QETB1HM-475E	4.7MF 50V E. CAP.	
	C614	QETB1HM-475E	4.7MF 50V E. CAP.	
	C615	QFV81HJ-154	0.15MF 50V THIN FILM CAP.	
	C616	QFV81HJ-154	0.15MF 50V THIN FILM CAP.	
	C617	QETB1HM-335	3.3MF 50V AL E. CAP.	
	C618	QETB1HM-335	3.3MF 50V AL E. CAP.	
	C619	QFV81HJ-154	0.15MF 50V THIN FILM CAP.	
	C620	QFV81HJ-154	0.15MF 50V THIN FILM CAP.	
	C621	QFN31HJ-223ZN	0.022MF 50V MYLAR CAP.	
	C622	QFN31HJ-473ZN	0.047MF 50V MYLAR CAP.	
	C623	QETC1EM-227ZN	220MF 25V AL E. CAP.	
	C624	QETB1EM-106	10MF 25V AL E. CAP.	
	C625	QETB1EM-106	10MF 25V AL E. CAP.	
	C626	QETB1EM-106	10MF 25V AL E. CAP.	
	C627	QETB1EM-106	10MF 25V AL E. CAP.	
	C628	QETC1EM-227ZN	220MF 25V AL E. CAP.	
	C631	QETB1EM-476	47MF 25V AL E. CAP.	
	C632	QFV71HJ-474ZM	0.47MF 50V THIN FILM CAP.	
	C633	QCS31HJ-681Z	680PF 50V CER. CAP.	
	C634	QETC1EM-227ZN	220MF 25V AL E. CAP.	
	C641	QETB1HM-474	0.47MF 50V E. CAP.	
	C643	QETB1HM-225	2.2MF 50V AL E. CAP.	

△	Item	Parts Number	Description	Area
	C644	QETC1EM-227ZN	220MF 25V AL E. CAP.	
	C645	QFN81HJ-823	0.082MF 50V METAL MYLAR	
	C646	QFN31HJ-332Z	3300PF 50V MYLAR CAP.	
	C647	QFN81HJ-823	0.082MF 50V METAL MYLAR	
	C648	QETB1HM-474	0.47MF 50V E. CAP.	
	C649	QCZ0205-155	1.5MF 25V C. CAP.	
	C650	QETC1EM-227ZN	220MF 25V AL E. CAP.	
	C651	QCS21HJ-300	30PF 50V CER. CAP.	
	C652	QCS21HJ-300	30PF 50V CER. CAP.	
	C881	QCE22HP-103A	0.01MF 500V CER. CAP.	
	C882	QCE22HP-103A	0.01MF 500V CER. CAP.	
	C883	QCE22HP-103A	0.01MF 500V CER. CAP.	
	C884	QCE22HP-103A	0.01MF 500V CER. CAP.	
	C885	QCE22HP-103A	0.01MF 500V CER. CAP.	
	C886	QCE22HP-103A	0.01MF 500V CER. CAP.	
		RESISTORS		
	R221	QRD161J-750	75 1/6W CARBON RES.	
	R222	QRD161J-750	75 1/6W CARBON RES.	
	R223	QRD161J-750	75 1/6W CARBON RES.	
	R224	QRD167J-680	68 1/6W CARBON RES.	
	R225	QRD167J-332	3.3K 1/6W CARBON RES.	
	R226	QRD167J-332	3.3K 1/6W CARBON RES.	
	R228	QRD161J-101	100 1/6W CARBON RES.	
	R229	QRD161J-203	20K 1/6W CARBON RES.	
	R231	QRD161J-561	560 1/6W CARBON RES.	
	R232	QRD161J-561	560 1/6W CARBON RES.	
	R233	QRD161J-561	560 1/6W CARBON RES.	
	R235	QRD161J-331	330 1/6W CARBON RES.	
	R236	QRD161J-331	330 1/6W CARBON RES.	
	R237	QRD167J-682	6.8K 1/6W CARBON RES.	
	R239	QRD167J-151	150 1/6W CARBON RES.	
	R240	QRD161J-102	1K 1/6W CARBON RES.	
	R241	QRD161J-621	620 1/6W CARBON RES.	
	R243	QRD161J-331	330 1/6W CARBON RES.	
	R251	QAD0095-4R7Z	4.7PF POSITIVE THER	
	R252	QRD167J-152	1.5K 1/6W CARBON RES.	
	R253	QRD167J-223	22K 1/6W CARBON RES.	
	R254	QRD161J-104	100K 1/6W CARBON RES.	
△	R255	QRD14CJ-100SX	10 1/4W UNF. CARBON R	
△	R262	QRX012J-2R2AF	2.2 1W METAL FILM R	
	R263	QRD167J-562	5.6K 1/6W CARBON RES.	
	R264	QRD167J-822	8.2K 1/6W CARBON RES.	
	R265	QRD161J-103	10K 1/6W CARBON RES.	
△	R266	QRD14CJ-2R2SX	2.2 1/4W UNF. CARBON R	
	R301	QRD161J-222	2.2K 1/6W CARBON RES.	
	R302	QRD161J-222	2.2K 1/6W CARBON RES.	
	R303	QRD161J-473	47K 1/6W CARBON RES.	
	R304	QRD161J-473	47K 1/6W CARBON RES.	
	R305	QRD161J-561	560 1/6W CARBON RES.	
	R306	QRD161J-561	560 1/6W CARBON RES.	
	R307	QRD161J-393	39K 1/6W CARBON RES.	
	R308	QRD161J-393	39K 1/6W CARBON RES.	
	R309	QRD161J-474	470K 1/6W CARBON RES.	
	R310	QRD161J-474	470K 1/6W CARBON RES.	
	R311	QRD161J-104	100K 1/6W CARBON RES.	
	R312	QRD161J-104	100K 1/6W CARBON RES.	
△	R313	QRD14CJ-391SX	390 1/4W UNF. CARBON R	
△	R314	QRD14CJ-391SX	390 1/4W UNF. CARBON R	
△	R321	QRZ0077-680	68 1/4W FUSIBLE RES.	
△	R322	QRZ0077-680	68 1/4W FUSIBLE RES.	
	R325	QRD161J-471	470 1/6W CARBON RES.	
	R326	QRD161J-471	470 1/6W CARBON RES.	
	R327	QRD161J-471	470 1/6W CARBON RES.	
	R328	QRD161J-471	470 1/6W CARBON RES.	
	R329	QRD161J-471	470 1/6W CARBON RES.	
	R330	QRD161J-471	470 1/6W CARBON RES.	
	R331	QRD161J-471	470 1/6W CARBON RES.	
	R332	QRD161J-471	470 1/6W CARBON RES.	



## ■ Electrical Parts List (ENC-138)

△	Item	Parts Number	Description	Area
	R333	QRD161J-471	470 1/6W CARBON RES.	
	R334	QRD161J-471	470 1/6W CARBON RES.	
	R335	QRD161J-471	470 1/6W CARBON RES.	
	R336	QRD161J-471	470 1/6W CARBON RES.	
	R337	QRD161J-471	470 1/6W CARBON RES.	
	R338	QRD161J-471	470 1/6W CARBON RES.	
	R341	QRD161J-104	100K 1/6W CARBON RES.	
	R342	QRD161J-104	100K 1/6W CARBON RES.	
	R343	QRD161J-104	100K 1/6W CARBON RES.	
	R344	QRD161J-104	100K 1/6W CARBON RES.	
	R347	QRD161J-102	1K 1/6W CARBON RES.	
	R348	QRD161J-102	1K 1/6W CARBON RES.	
△	R349	QRZ0077-680	68 1/4W FUSIBLE RES.	
△	R350	QRZ0077-680	68 1/4W FUSIBLE RES.	
	R351	QRD161J-124	120K 1/6W CARBON RES.	
	R352	QRD161J-124	120K 1/6W CARBON RES.	
	R353	QRD161J-432	4.3K 1/6W CARBON RES.	
	R354	QRD161J-432	4.3K 1/6W CARBON RES.	
	R355	QRD161J-103	10K 1/6W CARBON RES.	
	R356	QRD161J-103	10K 1/6W CARBON RES.	
△	R357	QRZ0077-680	68 1/4W FUSIBLE RES.	
△	R358	QRZ0077-680	68 1/4W FUSIBLE RES.	
	R359	QRD161J-104	100K 1/6W CARBON RES.	
	R360	QRD161J-104	100K 1/6W CARBON RES.	
	R361	QRD161J-104	100K 1/6W CARBON RES.	
	R362	QRD161J-104	100K 1/6W CARBON RES.	
	R363	QRD161J-393	39K 1/6W CARBON RES.	
	R364	QRD161J-393	39K 1/6W CARBON RES.	
	R365	QRD161J-224	220K 1/6W CARBON RES.	
	R366	QRD161J-224	220K 1/6W CARBON RES.	
	R367	QRD161J-124	120K 1/6W CARBON RES.	
	R368	QRD161J-124	120K 1/6W CARBON RES.	
	R369	QRD161J-124	120K 1/6W CARBON RES.	
	R370	QRD161J-124	120K 1/6W CARBON RES.	
	R371	QRD161J-103	10K 1/6W CARBON RES.	
	R372	QRD161J-103	10K 1/6W CARBON RES.	
	R373	QRD167J-562	5.6K 1/6W CARBON RES.	
	R375	QRD161J-102	1K 1/6W CARBON RES.	
	R376	QRD167J-562	5.6K 1/6W CARBON RES.	
	R377	QRD161J-102	1K 1/6W CARBON RES.	
	R378	QRD161J-102	1K 1/6W CARBON RES.	
	R380	QRD161J-102	1K 1/6W CARBON RES.	
	R381	QRD161J-124	120K 1/6W CARBON RES.	
	R382	QRD161J-124	120K 1/6W CARBON RES.	
	R385	QRD161J-103	10K 1/6W CARBON RES.	
	R386	QRD161J-103	10K 1/6W CARBON RES.	
	R390	QRD161J-103	10K 1/6W CARBON RES.	
△	R391	QRZ0077-680	68 1/4W FUSIBLE RES.	
△	R392	QRZ0077-680	68 1/4W FUSIBLE RES.	
	R393	QRD167J-511	510 1/6W CARBON RES.	
	R394	QRD167J-511	510 1/6W CARBON RES.	
	R395	QRD161J-333	33K 1/6W CARBON RES.	
	R396	QRD161J-333	33K 1/6W CARBON RES.	
	R557	QRD161J-103	10K 1/6W CARBON RES.	
	R558	QRD161J-103	10K 1/6W CARBON RES.	
	R559	QRD167J-113	11K 1/6W CARBON RES.	
	R560	QRD167J-113	11K 1/6W CARBON RES.	
	R561	QRD161J-104	100K 1/6W CARBON RES.	
	R562	QRD161J-104	100K 1/6W CARBON RES.	
	R563	QRD161J-333	33K 1/6W CARBON RES.	
	R564	QRD161J-333	33K 1/6W CARBON RES.	
	R565	QRD161J-124	120K 1/6W CARBON RES.	
	R566	QRD161J-124	120K 1/6W CARBON RES.	
△	R571	QRZ0077-471	470 1/4W FUSIBLE RES.	
△	R572	QRZ0077-471	470 1/4W FUSIBLE RES.	
	R573	QRD161J-681	680 1/6W CARBON RES.	
	R574	QRD167J-272	2.7K 1/6W CARBON RES.	
	R641	QRD161J-102	1K 1/6W CARBON RES.	
	R642	QRD161J-102	1K 1/6W CARBON RES.	
	R643	QRD161J-163	16K 1/6W CARBON RES.	
	R644	QRD161J-393	39K 1/6W CARBON RES.	
	R651	QRD161J-105	1M 1/6W CARBON RES.	
	R662	QRD161J-102	1K 1/6W CARBON RES.	
	R663	QRD161J-102	1K 1/6W CARBON RES.	
	R666	QRD161J-474	470K 1/6W CARBON RES.	
△	R881	QRX012J-R22A	0.22 1W METAL FILM R	
△	R882	QRX012J-R22A	0.22 1W METAL FILM R	
	RA551	QRB039J-474	470K 1/10W CARBON RES.	
	RA552	QRB039J-474	470K 1/10W CARBON RES.	
		OTHERS		
		EMW10703-003KP	CTR. BOARD	
		SBSG3008CC	TAPPING SCREW	
	J221	EMN00TV-116A	PIN JACK	
	J222	EMN01TV-102A	PIN JACK	
	J223	EMN00YV-217A	PIN JACK	
	J301	EMN00TV-422AJ2	PIN JACK	
	J302	EMN00TV-622AJ2	PIN JACK	
	J303	EMN00TV-622AJ2	PIN JACK	
	L221	EQL4004-220	INDUCTOR	
	X221	ECX0143-1818EWT	CRYSTAL	
	X641	ECXP8R0-001Z	CRYSTAL	
	BK800	E310098-001SM	WIRE HOLDER	C
	CN312	EMV5109-003B	CONNECT TERMINAL	
	CN413	EMV5109-009A	PIN PLUG	
	CN415	VMC0163-013	CONNECT TERMINAL	
	CN418	EMV5109-004A	MALE CONNECTOR	
	CN511	EMV5163-011R	CONNECT TERMINAL	
	CN603	EMV7163-009	CONNECT TERMINAL	
	CN611	EMV5163-007R	CONNECT TERMINAL	
	CN612	EMV5163-011R	CONNECT TERMINAL	
	CN613	EMV5163-009R	CONNECT TERMINAL	
	CN802	EWS273-005	SOCKET WIRE ASSY	
	CN803	VMC0177-003	CONNECT TERMINAL	
	CN805	EMV7163-007	CONNECT TERMINAL	
	CN811	EMV5163-007R	CONNECT TERMINAL	
	CN815	EMV5163-007R	CONNECT TERMINAL	
	EP250	EMZ4002-002Z	EARTH PLATE	
	FC881	EMG7331-003Z	FUSE CLIP	
	FC882	EMG7331-003Z	FUSE CLIP	
	FC883	EMG7331-003Z	FUSE CLIP	
	FC884	EMG7331-003Z	FUSE CLIP	
	FW211	EWR37D-16LS	FLAT WIRE	
	HS881	E408032-002SS	HEAT SINK	
	RY881	QSK0064-001	RELAY	

## ■ Accessory List

Block No. M 2 M M

△	Item	Parts Number	Parts Name	Q'ty	Description	Area
	1	LET0052-001A	INSTRUCTION BOOK	1		J
		LET0052-002A	INSTRUCTION BOOK	1		C
	2	E309758-001	POLY BAG	1		
	3	RM-SR772U	WIRE-LESS REMOTE CONTROL	1		
	4	BT-52002-1	WARRANTY CARD	1		C
	5	BT-20071B	SERVICE NETWORK	1		C
	6	EGB4001-015	LOOP ANTENNA	1		
	7	EWP201-011	ANTENNA WIRE	1		
	8	R03UPTT-2S1	DRY CELL	2		
	9	BT-51006-1	REGISTER CARD	1		J
	10	BT-20044G	SAFETY SHEET	1		J

Packing Materials and Part Numbers

Block No. M 3 M M

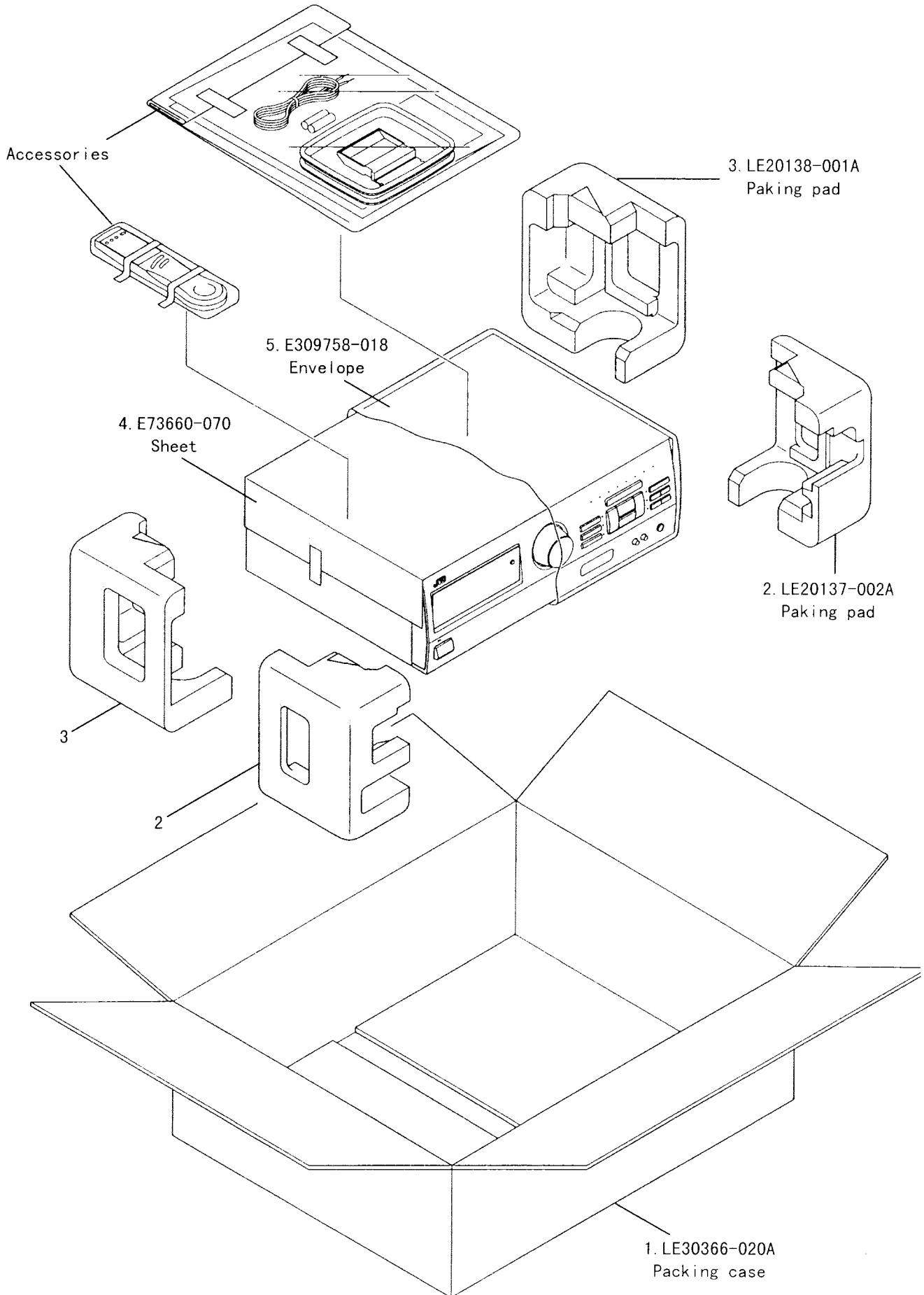

**JVC**

VICTOR COMPANY OF JAPAN, LIMITED  
AUDIO DIVISION 10-1, 1-chome, Ohwatari-machi, Maebashi-city, Japan